



This is a digital copy of a book that was preserved for generations on library shelves before it was carefully scanned by Google as part of a project to make the world's books discoverable online.

It has survived long enough for the copyright to expire and the book to enter the public domain. A public domain book is one that was never subject to copyright or whose legal copyright term has expired. Whether a book is in the public domain may vary country to country. Public domain books are our gateways to the past, representing a wealth of history, culture and knowledge that's often difficult to discover.

Marks, notations and other marginalia present in the original volume will appear in this file - a reminder of this book's long journey from the publisher to a library and finally to you.

Usage guidelines

Google is proud to partner with libraries to digitize public domain materials and make them widely accessible. Public domain books belong to the public and we are merely their custodians. Nevertheless, this work is expensive, so in order to keep providing this resource, we have taken steps to prevent abuse by commercial parties, including placing technical restrictions on automated querying.

We also ask that you:

- + *Make non-commercial use of the files* We designed Google Book Search for use by individuals, and we request that you use these files for personal, non-commercial purposes.
- + *Refrain from automated querying* Do not send automated queries of any sort to Google's system: If you are conducting research on machine translation, optical character recognition or other areas where access to a large amount of text is helpful, please contact us. We encourage the use of public domain materials for these purposes and may be able to help.
- + *Maintain attribution* The Google "watermark" you see on each file is essential for informing people about this project and helping them find additional materials through Google Book Search. Please do not remove it.
- + *Keep it legal* Whatever your use, remember that you are responsible for ensuring that what you are doing is legal. Do not assume that just because we believe a book is in the public domain for users in the United States, that the work is also in the public domain for users in other countries. Whether a book is still in copyright varies from country to country, and we can't offer guidance on whether any specific use of any specific book is allowed. Please do not assume that a book's appearance in Google Book Search means it can be used in any manner anywhere in the world. Copyright infringement liability can be quite severe.

About Google Book Search

Google's mission is to organize the world's information and to make it universally accessible and useful. Google Book Search helps readers discover the world's books while helping authors and publishers reach new audiences. You can search through the full text of this book on the web at <http://books.google.com/>



GODFREY LOWELL CABOT SCIENCE LIBRARY
of the Harvard College Library

**This book is
FRAGILE**
and circulates only with permission.
Please handle with care
and consult a staff member
before photocopying.

**Thanks for your help in preserving
Harvard's library collections.**



RUDIMENTS
OF
NAVAL ARCHITECTURE;
OR,
AN EXPOSITION
OF THE
ELEMENTARY PRINCIPLES OF THE SCIENCE
AND THE
PRACTICAL APPLICATION
TO
NAVAL CONSTRUCTION;
COMPILED FOR THE
USE OF BEGINNERS.

BY
JAMES PEAKE,
ASSISTANT MASTER SHIPWRIGHT, H. M. DOCKYARD, WOOLWICH, AND
FORMERLY OF THE SCHOOL OF NAVAL ARCHITECTURE,
H. M. DOCKYARD, PORTSMOUTH.

London :
JOHN WEALE,
ARCHITECTURAL LIBRARY, 59, HIGH HOLBORN.

M.DCCC.XLIX.

Eng. 5052.47

UNIVERSITY OF
CAMBRIDGE

JUN 20 1917 ~~2121~~
TRANSFERRED TO
CANTON COLLEGE LIBRARY

LONDON:
STEVENS AND CO., PRINTERS, BELL YARD,
TEMPLE BAR.

219
5-2

C O N T E N T S.

PART I.

The Displacement of a Floating Body considered.—Application of the Law thus determined to the Displacement of a Ship, when treated as a Floating Body.—The Calculations on the Immersed Portions of a Ship absolutely necessary to avoid Failure and Unnecessary Expense in such Costly Fabrics Page 3

PART II.

The Application of Sterling's Rules to the Measurement of Areas, bounded by a Straight Line as a Base and a Curve Line; the first Rule requiring an odd Number of Ordinates, the second Rule that the Ordinates must be in Number a Multiple of the numeral three, with one added . P. 5

PART III.

Method of applying Sterling's Rules to ascertain the Solidity of the Bulk of Fluid displaced by the Immersed Portion of a Ship.—2nd. A Method of obtaining the same under a more Concise Mode of Application of the same Rules, by means of a Double-columned Table for the Insertion of the Measured Ordinates of the Areas P. 8

PART IV.

The Calculations already made by Sterling's Rules for ascertaining the Volume Immersed, applied to determine the Position of the Centre of Gravity of that Volume, or of that of the Displacement.—Position of the Centre of Gravity of a System of Bodies.—The same Reasoning applied to find the Centre of Gravity of Displacement of a Ship.—Its Application under the System of using a Double Table of Ordinates . P. 13

PART V.

Method of describing a Curve of Vertical Sectional Areas.—Its Application to the Calculations required on the Immersed Portion of a Ship.—1st. To the Displacement.—Relative Capacities of the Fore and After

Bodies of Immersion, denoted by the Area of Sections.—The Light Displacement or Weight of the Hull of the Vessel, obtained under the same System.—Practical Utility of it in stowing the Hold of the Vessel with Stores and Weights.—The Sectional Area measured by Sterling's Second Rule P. 15

PART VI.

Preliminary Remarks previous to the Application of the Rules for Calculation to the Construction-draught of a Yacht of 36 Tons Admeasurement, old tonnage.—The Immersed Part of a Vessel considered as a Portion of the Parallelopipodon formed by the Dimensions of Length, Breadth, and Depth.—Relative Capacities of the two Bodies, or Fore and After Bodies, under the Half-lengths of the Load-water Line.—Example of Bad Construction in this Element.—Man-of-War Brigs of 1833.—The Accuracy of the Stowage of the Hold ensured by the Delineation of the Curves of Sectional Areas for Light and Load Immersions.—The Relative Capacities of the two Bodies under the same Displacement affect the Form Forward and Aft P. 19

PART VII.

Curve of Sectional Areas, applicable to the Comparison of the Relative Qualities of Ships of the same Rate, will give a Scale for Tonnage of Displacement under any Immersion.—Method of forming the Scale of Displacement P. 22

PART VIII.

Description of Fig. 8, or of the several Plans to be delineated by the Draughtsman, previous to the Commencement of the Calculations. P. 23

PART IX.

Application of Sterling's Rules to the Calculations required for the Construction-drawing of a Yacht of 36 Tons, old measurement.—Fig. 8. 1st. Usual Mode of Calculating the Displacement by Vertical and Horizontal Sections P. 25

PART X.

By the usual Method.—Area of Midship or greatest Transverse Section.—Area of the Load-water Line, or Area of the assumed Plane of Deepest Immersion.—Capacity to the Inch at that Immersion in Cubic Feet, and Tons of 35 Cubic Feet of Space.—Longitudinal Distance of the Centre of Gravity of Displacement from Section 1, considered as the

Initial Plane.—Distance the Centre of Gravity is below the Load-water Line, or Line of assumed Deepest Immersion.—Distance of the Centre of Gravity of the Load-water Section from the Section 1 of Fig. 8 P. 41

PART XI.

By the usual Method.—Relative Capacity of the Bodies immersed under the Fore and After Lengths of the Load-water Line.—Per Centage of the Bodies.—Height of the Metacentre as the Comparative Measure of the Stability or Stiffness under Canvas of Vessel of the same dimensions.—Summary of the Results of the Calculations . . . P. 46

PART XII.

Second Method.—The Calculations under the Form of a Double-columned Table of Ordinates.—Displacement.—Area of Midship Section.—Area of Load-water-Line.—Position of the Centre of Gravity of Displacement.—Position of the Centre of Gravity of the Load-water Section.—Relative Capacity of the Two Bodies under the Fore and After Half-length of the Load-water Line.—Height of the Metacentre.—Contrasted Elements of the Vessel obtained under the Two Methods . . . P. 50

PART XIII.

Method of forming a Curve of Sectional Areas from a Drawing of Ship.—Calculations for the Displacement from it.—Application of the Method to the Yacht of 36 Tons Admeasurement.—Relative Capacity of the Fore and After Bodies of the Yacht pointed out by the Curve.—Area of Midship Section of the same.—Curve of Sectional Areas used to obtain the Centre of Gravity of Displacement.—Application of it to the Yacht of 36 Tons Admeasurement P. 57

PART XIV.

General Terms of the Curve of Sectional Areas when applied to Naval Construction.—Practical Operations under that System to the Yacht of 36 Tons Admeasurement.—The Method applied to the Construction of a Frigate whose Displacement is 2300 Tons P. 66

PART XV.

Preliminary Remarks.—Methods of Calculation for the Areas of the Sails.—Method of finding the Centres of Gravity of Sails, and determining the Position of the Centre of Effort of the Moving Force or the Sails of a Ship P. 74

PART XVI.

Scale of Capacity for the Yacht of 36 Tons Admeasurement . . . P. 81

PART XVII.

An Example of the Comparison of the Forms of Ships, by the Curve of Sections being applied to the Vertical Sections of Her Majesty's Ship Vanguard, of the year 1835, and the French Canopus, of the year 1786; and a further Application of the Curve of Sectional Areas to the Light and Load Displacements of the same Men-of-War; with a view of showing their relative Capacities for carrying Weights, and to facilitate their Stowage, as pointed out in page 17 P. 92

PART XVIII.

Application of the Curve of Sectional Areas to the Stowage of the Hold of Her Majesty's Ship Canopus, with Reference to the Directions given at page 21 of this work P. 112

PART XIX.

A Demonstration of the Expression $\frac{2}{3} \int \frac{y^3 dx}{D}$ as being a Measure of comparative Stability or Stiffness of Floating Bodies, more usually denominated the Height of the Metacentre above the Centre of Gravity of Displacement of the Immersed Portion of the Body P. 114

PART XX.

Investigation of a General Expression for the Stability of a Ship at Finite Angles of Inclination, and the Application of the Results to calculating the Stability of H. M. Ships Vanguard and Canopus, at an Angle of Seven Degrees P. 118

PART XXI.

The Volumes of Immersion and Emersion of H. M. Ships Vanguard and Canopus, calculated to an Angle of 7° .—Concluding Remarks and Observations P. 122

P R E F A C E .

As every other branch of useful knowledge and science is said to be overwhelmed by initiatory works for the state in them, it is no slight reflection on the Naval Science-department of this great maritime country, that neither rudimentary nor elementary works on the science of Naval Architecture, the labours of British Naval Architects, are to be found amongst the standard works of our libraries. Humiliating as this assertion may be deemed, the fact remains incontrovertible. There are, no doubt, works on Naval Architecture by the Swedish constructor Chapman, and the no less eminently talented Naval architect Clairbois; and these, by the industry of Englishmen, have been translated and made capable of adaptation to the requirements of the British Naval Architect; but these works, from the depth of mathematical knowledge required for their perusal, and from the expense attending on their purchase, are sealed sources of information to practical and demi-scientific men, and are no less the results of the gifted minds of foreigners, who have directed their energies to a subject of such paramount moment to the British Empire, as the improvement of the science of Naval Architecture. The imputation of want of energy—I will not say want of talent—remains at our door; and if this rudimentary work, on the necessary calculations to be made for a Naval Construction, should excite emulation in this branch of science,

which is of such vast importance to England, as being the first Marine Power of the world, one end will have been obtained ; and, in addition, I shall feel no small degree of pleasure in having added my mite to the general fund of useful knowledge, by placing in the hands of the young Naval Architect a Rudimentary Text-Book on Naval Construction.

J. P. P.

WOOLWICH,
July, 1849.

RUDIMENTARY NAVAL ARCHITECTURE.

PART I.

The Displacement of a Floating Body considered.—Application of the Law thus determined to the Displacement of a Ship, when treated as a Floating Body.—The Calculations on the Immersed Portions of a Ship absolutely necessary to avoid Failure and Unnecessary Expense in such Costly Fabrics.

WHEN a body floats on a fluid, it displaces as much of that fluid as is equal in size and form to the portion of the body which is immersed, and the bulk of fluid thus displaced is known to be equivalent in weight to the weight of the whole body; the measure therefore in solidity, of the portion of the body that is immersed, will give the magnitude of the fluid displaced, and the weight of this bulk of fluid will give the weight of the floating body.

It being the object of the naval constructor to ascertain with accuracy the displacement and immersion of a ship, it becomes thence necessary to measure that portion of the body of the ship which it is proposed should be immersed; to effect which, Stirling's Rules of Differentials have been employed by the Swedish constructor Chapman, and French naval architect Clairbois. Their application of these Rules cannot be too highly prized by the naval architect, giving, as they do with precision, the volume displaced, the position of the centre of gravity of that displacement, and a comparative stability of ships.

In applying the methods thus adopted by Chapman and Clairbois in detail to an example in naval construction, it will

be the earnest endeavour in this Rudimentary Work on Naval Architecture to divest the subject of all technicalities, and to place it within the comprehension of the uninitiated in this branch of scientific knowledge; and if the garb in which the intended instruction is clothed should be thought too simple by those to whom the application of these calculations may be an every-day occurrence, it is at once admitted, that these rudiments were not written for their edification, although the careful perusal of them may, even by such proficient, be found to be not wholly without profit and utility.

After having made the novice in these matters acquainted with the ordinary modes of conducting these essential calculations on the immersed portion of a ship, a more concise method of applying the same rules will be given, which will be followed by these rules being employed under a system which will be found greatly to facilitate the labours of the naval constructor, to register and compare the forms of ships, whether mercantile or for the purposes of war, and by which the qualities of a design for any proposed ship may be developed with certainty, and the errors of a constructor be made apparent before his design is put into practice; thence avoiding the disgrace, together with the useless and vast expense which ever await on an unsystematic arrangement of important calculations, and on unscientific deductions from ill-digested and misunderstood results. It is not intended to give the mathematical demonstrations on which these rules are founded—as the knowledge required to follow such demonstrations to the desired end is beyond the assumed acquirements of the novice—the truth of these rules must be taken by such persons with faith; and to the scientific no appeal is required in favour of the ground-work of the calculations, the accuracy of Sterling's Rules having been tested by the unerring results given by mathematical research, confirmed as they have been by years of practical experience.

PART II.

The Application of Sterling's Rules to the Measurement of Areas, bounded by a Straight Line as a Base and a Curve Line ; the first Rule requiring an odd Number of Ordinates, the second Rule that the Ordinates must be in Number a Multiple of the numeral three, with one added.

Two rules were given by Sterling for measuring the area or superficial space enclosed by a curve, and a straight line taken as a base ; thus, in FIG. 1.

FIG. 1.

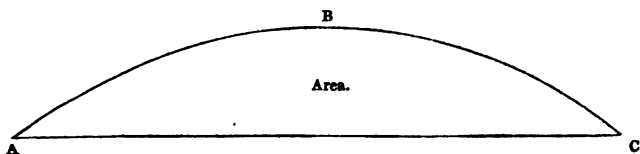

A B C is the curve line, and A C the base.

RULE THE FIRST.

If the area bounded by the curve line A B C and the straight line A C is required to be estimated, by the rule, the base A C is divided into an even number of equal parts, as in the Fig. No. 2, to give an odd number of points of division.

FIG. 2.

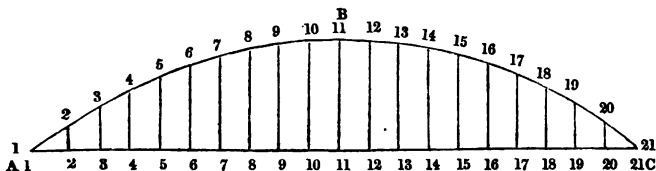

Where the base A C is divided into twenty equal parts, giving twenty-one points of division, and the lines 1.1, 2.2, 3.3, &c.,

are drawn from these points at right angles or square to A C, to meet the curve A B C, these lines, 1.1, 2.2, 3.3, &c., are denominated ordinates, and the linear measurement of them, on a scale of parts, is taken and used in the following general expression of the rule.

$$\text{Area} = \{A + 4 P + 2 Q\} \frac{r}{3}.$$

Where A = sum of the first and last ordinates, or 1.1 and 21.21 of Fig. 2.

4 P = sum of the even ordinates multiplied by 4.

Or, $\{2^{\text{nd}} + 4^{\text{th}} + 6^{\text{th}} + 8^{\text{th}} + 10^{\text{th}} + 12^{\text{th}} + 14^{\text{th}} + 16^{\text{th}} + 18^{\text{th}} + 20^{\text{th}}\} \times 4$. Fig. 2.

2 Q = sum of the remaining ordinates; or,

$\{3^{\text{rd}} + 5^{\text{th}} + 7^{\text{th}} + 9^{\text{th}} + 11^{\text{th}} + 13^{\text{th}} + 15^{\text{th}} + 17^{\text{th}} + 19^{\text{th}}\} \times 2$.
Fig. 2.

And r is equal to the linear measurement of the common interval between the ordinates, or one of the equal divisions of the base A C. This rule, for determining the area contained under the curve and the base, may be put under another form; for as the

$\text{Area} = \{A + 4 P + 2 Q\} \times \frac{r}{3}$;
it may be transferred into

$$\text{Area} = \left\{ \frac{A}{2} + 2 P + Q \right\} \times \frac{2 r}{3}.$$

The practical advantages to be derived from this modification of the general rule will appear when the methods of calculation are further developed.

RULE THE SECOND.

FIG. 3.

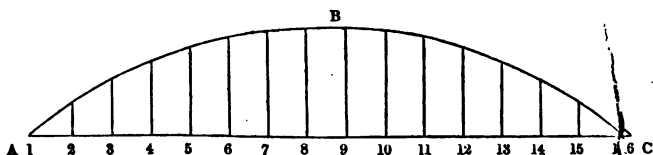

If the base A C be so divided that the equal intervals are in number a multiple of the numeral 3, then the total number

of the points of division, and consequently the ordinates to the curve, will be a multiple of the numeral 3 with one added, and the area under the curve A B C, and the base A C, can be determined by the following general expression :

$$\text{Area} = \{ A + 2 P + 3 Q \} \times \frac{r}{6}.$$

Where A = sum of the first and last ordinates, or 1 and 16. Fig. 3.

2 P = sum of the 4th, 7th, 10th, 13th, multiplied by 2, or ordinates bearing the distinction of being in position as multiples of the numeral 3, with one added. Fig. 3.

3 Q, the sum of the remaining ordinates, multiplied by 3, or of the 2nd, 3rd, 5th, 6th, 7th, 8th, 9th, 11th, 12th, 14th, and 15th, multiplied by 3. Fig. 3.

The number of equal divisions for this rule must be either 3, 6, 9, 12, or 15, &c., being multiples of the numeral 3, whence the ordinates will be in number under such divisions, multiples of the numeral 3, with one added.

This rule admits also of a modification in form, to make it more convenient of application.

For Area = $\{ A + 2 P + 3 Q \} \times \frac{2}{3} r$,
may be transformed to

$$\text{Area} = \left\{ \frac{A}{2} + P + 1.5 Q \right\} \times \frac{2}{3} r.$$

As before advanced for the change adopted in the general expression for the first rule, the utility of this modification of the second rule will be observable when the calculations on the immersed body are proceeded with.

The rules are formed under the supposition that in the 1st rule the curve A B C, which passes through the extremities of the ordinates, is a portion of a common parabola, while in the second rule the curve is assumed to be a cubic parabola; the results to be obtained from an indiscriminate use of either of these rules, differ from each other in so trifling a degree (considered practically and not mathematically), as not to sensibly affect the deductions derived by them.

PART III.

Method of applying Sterling's Rules to ascertain the Solidity of the Bulk of Fluid displaced by the Immersed Portion of a Ship.—2nd. A Method of obtaining the same under a more Concise Mode of Application of the same Rules, by means of a Double-columned Table for the Insertion of the Measured Ordinates of the Areas.

STERLING'S Rules, when applied to the measurement of the immersed portion of a floating body, as the displacement of a ship, are used as follows.

The ship is considered as being divided longitudinally by equi-distant athwartship or transverse vertical planes, the boundaries of which planes give the external form of the vessel at the respective stations, and therefore the comparative forms of any intermediate portion of it.

FIG. 4.

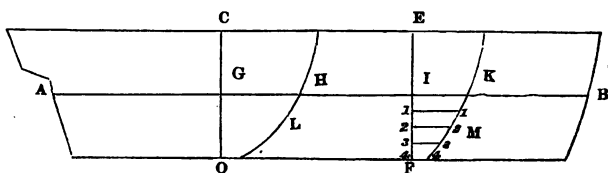

If the ship be immersed to the line AB, Fig. 4, considered as the line of the proposed deepest immersion or lading, the curves HLO and KMF would give the external form of the ship at the positions G and I in that line; and the areas GHLO, IKMF contained under the curves HLO, KMF, the right lines GH, IK (the half-breadths of the plane of proposed floatation AB at the points G and I), and the right lines GO, IF, the immersed depths of the body at those points are the areas to be measured by the Rules 1 or 2; and if the areas thus obtained be represented by linear

measurements, and are set off on lines drawn at right angles to the line *AB* at their respective stations, a curve bounding the representative areas would be formed, and the measurement by Sterling's Rules of the area contained under this curve, and the right line, *AB*, Fig. 4, or length of the ship on the load-water line, would give the sum of the areas thus represented, and thence the solid contents of the immersed portion of the ship in cubic feet of space. In accordance with this application of Sterling's Rules to measure the displacement of the ship, the usual practice is to divide the ship into equi-distant vertical and longitudinal planes, the longitudinal planes being parallel to the load-water section or horizontal section formed by the proposed deepest immersion.

To measure the areas of these planes after they have been delineated by the draughtsman, the constructor divides the depth of each of the vertical sections, or the length of each horizontal section, into such a number of equal divisions as will make either one or the other of the Rules 1 or 2 applicable. If the first rule be preferred, the equal divisions must be of an even number, so that there may be an odd number of ordinates; while the use of the second rule, to measure the area, will require the equal divisions of the base *AC*, Fig. 3, to be in number a multiple of the numeral 3, which will make the ordinates to be in number a multiple of the numeral 3, with one added. From the points of equal divisions in the respective sections thus determined, perpendicular ordinates are drawn to meet the curve, or the external form of the transverse planes of the body; and a table for the ordinates thus obtained, having been made as shown by Fig. 5, the measures by scale of the respective ordinates are therein inserted.

For the area *IKMF*, Fig. 4, the linear measurements of *IK*, 1.1, 2.2, 3.3, 4.4, are taken by a scale of parts, and inserted in the column marked 5, Fig. 5, the whole length *AB* of the load-water line being divided into 10 equal divisions, and the area *IKMF* being supposed as the fifth from *B*, the fore extreme of the load-water line. To apply the 1st

rule 1 to the measurement of the area of No. 5 section, the ordinates are extracted from the table, Fig. 5, and operated upon as directed by the rule; viz.

$$\text{Area} = \{ A + 4 P + 2 Q \} \times \frac{r}{3}.$$

I K, or first,	1.1, or 2nd,	2.2, or 3rd,
4.4, or last,	3.3, or 4th,	× 2.
	added together	or 2 Q.
added together	and × 4 = 4 P.	
= A.		

$$\text{By rule, Area} = \{ A + 4 P + 2 Q \} \times \frac{r}{3}.$$

Whence Area = $\{ \overline{IK} + 4.4 + 1.1 + 3.3.4 + 2.2 \times 2 \} \times \frac{r}{3}$
 = area I K M F, Fig. 4; and, in a similar manner, may the several areas of the other transverse sections be determined.

When these areas have all been thus measured, they are to be summed by the same Rules; the areas themselves being considered as lines, and the result will give the solid for displacement in cubic feet. To shorten this tedious application of the formula given by Sterling's Rules, the arrangement of having double-columned tables of ordinates was introduced, as shown in Fig. 6, and for the more ready use of this enlarged table the modifications in the formula of Sterling's Rules before alluded to were adopted, that of

$$\text{Area} = \{ A + 4 P + 2 Q \} \times \frac{r}{3} \text{ into } \left\{ \frac{A}{2} + 2 P + Q \right\} + \frac{2r}{3},$$

and that of

$$\text{Area} = \{ A + 2 P + 3 Q \} \times \frac{3r}{8} \text{ into } \left\{ \frac{A}{2} + P + 1.5 Q \right\} \times \frac{1}{2} r,$$

as rendering the required number of figures much less, whereby accuracy of calculation is ensured and time is saved.

In using a table of ordinates constructed for this method of calculation, the linear measurement of the several ordinates of vertical section 5 and the corresponding ones of all the others would be inserted in the double columns prepared for them in the following order:—

In the first and last lines of the enlarged table for the ordinates, distinguishable by $\frac{A}{2}$, in the left-hand column of each pair, the measurements of the first and last ordinates of the respective areas are placed, and in the right-hand column of each pair one-half of such measurements as being one-half of the first and last ordinates of each vertical section or area. In the lines distinguished by $2 P$, in the left-hand column, the measurements of the even ordinates of each respective area are placed, which having been multiplied by two, the result is placed in the respective right-hand columns prepared for each vertical section ; while in those lines of the table distinguished by Q , the measurements of the ordinates themselves are placed in the right-hand columns, as not requiring by the modification of the rules any operation to be used on them, before being taken into the sum forming the sub-multiple of the respective areas.

It may here with propriety be suggested, that in practice the insertion of the linear measurements of the ordinates in the table in red ink, as shown in Fig. 6, will be found useful, and that after such has been done, by the upper line of figures in the table of ordinates thus arranged, Fig. 6, being divided by two, the second line of figures being multiplied by two, and so on with the others as shown by the table, and the results thus obtained being inserted in their respective right-hand columns as before described, great facility and despatch of calculation are afforded to the constructor.

That this method will yield a correct measurement of the areas will be evident by an inspection of the terms of the general expression of Area = $\left\{ \frac{A}{2} + 2 P + Q \right\} \times \frac{2r}{3}$ which are placed against the several lines of the table of ordinates. And it will be equally apparent, that the sum total of the figures inserted in the right-hand columns appropriated to each section is a sub-multiple of the area of each section, and that these results arising from the use of the form for area of $\left\{ \frac{A}{2} + 2 P + Q \right\}$

will be one-half of those that would be obtained by abstracting the ordinates from the table, Fig. 5, and using them in the expression $A + 4 P + 2 Q$; and therefore to complete the calculation for the areas by the rule, the first results for the areas must be multiplied by $\frac{2r}{3}$, and the last by $\frac{r}{3}$, where r is equal to the common interval or equal division of the base in linear feet; or the part of the expression for areas of $\left\{ \frac{A}{2} + 2 P + Q \right\}$ must be multiplied by $\frac{2r}{3}$, to make it equivalent to $\{ A + 4 P + 2 Q \} \times \frac{r}{3}$.

The sub-multiples of the areas of the vertical sections thus determined, require to be summed together for the solid of displacement, and by considering the sub-multiples of the areas to be, as before stated, represented by lines or proportionate ordinates, Sterling's Rules, by the same table of ordinates with an additional column, may be made available to the development of the solid of displacement. For the sectional areas being represented by lines, by the first rule, $\frac{1}{2}$ the the first and last areas, added to the sum of the products arising from multiplying the even ordinates or representative areas by two, together with the odd ordinates or the areas as given by the tables, and these being placed in the additional column of the table prepared for them, the sub-multiple of the solid of displacement will be given.

The operation will stand thus: sub-multiple of each of the areas = $\left\{ \frac{A}{2} + 2 P + Q \right\}$, or each area will be $\frac{2r}{3}$ less than the full result, and the representative lines for the areas will be diminished in that proportion; and having used these sub-multiples of the areas thus diminished in the second operation for obtaining the sub-multiple of the solid of displacement under the same rule, the results will again be $\frac{2r'}{3}$ less than the true result; therefore the sum thus determined will have to

be multiplied by the quantity $\frac{2r}{3} \times \frac{2r'}{3}$, to give the solid required. In this expression, of $\frac{2r}{3} \times \frac{2r'}{3}$,

r = the equal distances taken in the vertical planes, to obtain the respective vertical areas ;

r' = equal distances at which the vertical areas are apart on the longitudinal plane of the ship.

PART IV.

The Calculations already made by Sterling's Rule for ascertaining the Volume Immersed, applied to determine the Position of the Centre of Gravity of that Volume, or of that of the Displacement,—Position of the Centre of Gravity of a System of Bodies.—The same Reasoning applied to find the Centre of Gravity of Displacement of a Ship.—Its Application under the System of using a Double Table of Ordinates.

THE displacement being thus determined, by an arrangement of an enlarged table of ordinates, the functions arising from the sub-multiples of the areas of the vertical sections being placed in Sterling's Rules to ascertain the displacement, may be used in the table of ordinates to find the distance of the centre of gravity of the immersed body from any assumed vertical plane ; and also the distance that the same point—"the centre of gravity of displacement"—is in depth from the load-water or line of deepest immersion, and that from the considerations which follow :—

In a system of bodies, the centre of gravity of it is found by multiplying the magnitude or density of each body by its respective distance from the beginning of the system, and dividing the sum of such products by the sum of the magnitudes or densities. The displacement of a ship may be considered as made up of a succession of vertical immersed areas ; and if it be assumed that the moments arising from multiplying the area of each section by its relative distance from an

initial plane, may be represented by successive linear measurements, Sterling's Rules will furnish the summation of such moments; and the displacement or sum of the areas has been obtained by a similar process, from whence, by the rule for finding the centre of gravity of a system as before given, the distance of the common centre of gravity from the assumed initial plane would be ascertained, by dividing the sum of the moments of the areas by the sum of the areas or the solid of displacement.

To extend this reasoning to the enlarged table of ordinates used for the 2nd method of calculation: the sub-multiples of the respective areas, when put into Sterling's Rules to obtain the proportionate solid of displacement, are relatively changed in value to give that solid, and consequently the moments of such functions of the vertical areas will be to each other in the same ratio; and the sum of these proportionate moments, if considered as lines, can be ascertained by multiplying the functions of the areas by their relative distances from the assumed initial plane, or by the number of the equal intervals of division they are respectively from it, and afterwards, by Sterling's Rules, summing these results, forming the sum of the moments of the sub-multiples of the functions of the vertical areas: and the proportionate sub-multiple for the displacement is shown on the table; the division therefore of the former, or the sum of the proportional moments of the functions of the areas, by the proportionate sub-multiple for the displacement, will give the distance (in intervals of equal division) that the centre of gravity of the displacement is from the initial plane, which being multiplied by the value in feet of the equal intervals between the areas, will give the distance in feet from the assumed initial plane, or from the extremity of the base line of the proportional sectional areas for displacement. This reasoning will apply equally to finding the position of the centre of gravity of the body immersed, both as respects length and depth, and on the enlarged tables for construction

given by Fig. 6, the constructor, by adopting this arrangement, will at once have under his observation the calculations *on*, and the results *of*, the most important elements of a Naval Construction.

PART V.

Method of describing a Curve of Vertical Sectional Areas.—Its Application to the Calculations required on the Immersed Portion of a Ship.—1st. To the Displacement.—Relative Capacities of the Fore and After Bodies of Immersion, denoted by the Area of Sections.—The Light Displacement or Weight of the Hull of the Vessel, obtained under the same System.—Practical Utility of it in stowing the Hold of the Vessel with Stores and Weights.—The Sectional Area measured by Sterling's Second Rule.

THE foregoing tabular system, for the application of Sterling's Rules to the calculations required on the immersed volume of a ship's bottom, led to a linear delineation of the numerical results of the tables, and thence the development of a curve of sectional areas, on a base equivalent to the length of the immersed portion of the body, or of the length at the load-water line. To effect this, the sub-multiples of the sectional areas, taken from the tables for calculation, are severally divided by such a constant number as to make their delineation convenient; then these thus further reduced sub-multiples of the areas, being set off at their respective positions on the base, formed by the length of the load-water line, a curve passed through the extreme points of these measurements, will bound an area, that to the depth used for the common divisor would form a zone, representative of the solid of displacement. The accuracy of such a representation will be easily admitted, if the former reasoning on Sterling's Rules is referred to.

To obtain the solid of displacement from this representative area, the load-water line or plane of deepest immersion is considered as being divided lengthways into two equal parts, which assumption divides the base of the curve of sectional areas also

into two equal portions : the line of representative area to that medial point is then drawn to the curve, and triangles are formed on each side of it by joining the point where it meets the curve with the extremities of the base line ; this arrangement divides the representative area into four parts, two triangles which are equal, viz. 1 and 2, and two other areas which are contained under the hypothenuses of these triangles and the curves of sections, or 3 and 4 of the annexed diagram.

DIAGRAM OF A CURVE OF SECTIONAL AREAS.

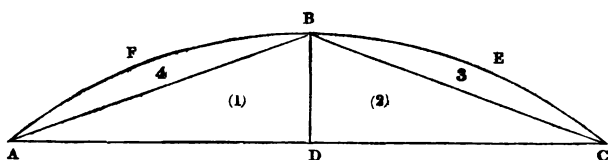

A B C D A = sectional area, representative of the half displacement as a zone of a given common depth.

A C equal the length of the load-water section from the fore-side of the rabbet of the stem to the aft-side of the rabbet of the post, and D the point of equal division.

B D, the representative area of half the immersed vertical section at the medial point D, joining B with the points A and C, will complete the division of the representative area A B C D A.

A B D and C B D, under such considerations, are equal triangles.

B E C B, B F A B, areas, bounded respectively by the hypothenuse A B or B C of the triangles and the curve of sectional areas ; and, supposing the curves A F B and B E C to be portions of common parabolas, the solid of displacement will be in the following terms :—

The area of each of the triangles is equal to $\frac{1}{2}$ of A C \times B D ; hence the sum of the two = $\frac{1}{2}$ of A C \times B D : the hypothenuse A B or B C = $\sqrt{\left(\frac{A C}{2}\right)^2 + B D^2}$; and the area of

B E C B if considered as approximating to a common parabola = $\sqrt{\frac{AC}{2}} + BD^2 \times \frac{1}{3}$ of the greatest perpendicular on the hypotenuse B C.

Area of B F A B under the same assumption = $\sqrt{\frac{AC}{2}} + BD^2 \times \frac{2}{3}$ of the greatest perpendicular on the hypotenuse A B; whence the whole displacement will be expressed by $\frac{1}{2} AC \times BD + \sqrt{\frac{AC}{2}} + BD^2 \times \frac{1}{3}$ of the greatest

perpendicular on the hypotenuse B C + $\sqrt{\frac{AC}{2}} + BD^2 \times \frac{2}{3}$ of the greatest perpendicular on the hypotenuse A B.

By a similar method, from the light draught of water, or the depth of immersion on launching the ship, the light displacement, or the weight of the hull or fabric, may be delineated and estimated; and the representative curve for it being placed relatively on the same base as that used for the representative curve for the load displacement, the area contained between the curve bounding the representative area for the load displacement, and the curve bounding the representative area for the light displacement, will be a representative area of the sum of the weights to be received on board, and point out their position to bring the ship from the light line of floatation, or the line of immersion due to the weight of the hull when completed in every respect, to that of the deepest immersion, or the proposed load-water line of the constructor—a representation that would enable the constructor to apportion the weights to be placed on board to the upward pressure of the water, and thence approximate to the stowage that would ensure the easiest movements of a ship in a sea.

By an inspection of the diagram of the curve of sectional areas, it will clearly be seen that the representative area for displacement under the division of it, into the triangles

1 and 2, and parabolic portions of the area 3 and 4, will point out the relative capacities of the displacement, under the fore and after half-lengths of the base or load-water line; for, by construction, the triangles A B D and C B D are equal, and therefore the comparative values of the areas B E C B and B F A B, or of $\sqrt{\left(\frac{A C}{2}\right)^2 + B D^2} \times \frac{2}{3}$ of the greatest perpendicular on the hypotenuse B C, compared with $\sqrt{\left(\frac{A C}{2}\right)^2 + B D^2} \times \frac{2}{3}$ of the greatest perpendicular on the hypotenuse A B, or of the relative values of the greatest perpendiculars on the hypotenuses B C and A B, will give the relative capacities of the fore and after portions of the immersed body or the displacement.

The representative area A B C D A, Fig. 7, admits also of a measurement by the 2nd Rule given by Sterling.

Let B D, as before, be the representative area at the middle point.

FIG 7.

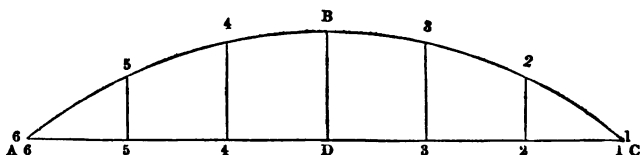

Divide A D or D C into three equal portions, then the equal divisions being a multiple of 3, the 2nd Rule is applicable to measure the areas A B D A or B C D B;

$$\begin{aligned} \text{for area A B D A} &= \left\{ 6.6 + B D + 2 \times 0 + 3 \overline{\{4.4 + 5.5\}} \right\} \frac{3r}{8}, \\ & \quad 6.6 = 0 \\ &= \left\{ B D + 3 \cdot \{4.4 + 5.5\} \right\} \frac{D C}{8}; \end{aligned}$$

$$\text{and area B C D B} = \left\{ 1.1 + B D + 2 \times 0 + 3 \times \{2.2 + 3.3\} \right\} \frac{3r}{8},$$

$$\text{where } 1.1 = 0 = \left\{ B D + 3 \times \overline{\{2.2 + 3.3\}} \right\} \frac{A D}{8};$$

and the displacement = $\left\{ BD + 3. \{ 4.4 + 5.5 \} \right\} \frac{DC}{8} + \left\{ BD + 3. \{ 2.2 + 3.3 \} \right\} \times \frac{AD}{8}$ x by the constant divisor of the areas, or the depth of the zone in feet.

The rules given by Sterling for the measurement of the immersed portion of the body of a ship, having been theoretically stated, the practical application of them will be given on the construction—drawing of a yacht of thirty-six tons. The system being the same for large or small vessels, want of space in this small work must be the accepted plea for the latter having been chosen, premising that the following considerations are necessary preparatory to the formation of a construction, or of a comparison of the elements of ships already built.

PART VI.

Preliminary Remarks previous to the Application of the Rules for Calculation to the Construction-draught of a Yacht of 36 Tons Admeasurement, old tonnage.—The Immersed Part of a Vessel considered as a Portion of the Parallelopipodon formed by the Dimensions of Length, Breadth, and Depth.—Relative Capacities of the two Bodies, or Fore and After Bodies, under the Half-lengths of the Load-water Line.—Example of Bad Construction in this Element.—Man-of-War Brigs of 1833.—The Accuracy of the Stowage of the Hold ensured by the Delineation of the Curves of Sectional Areas for Light and Load Immersions.—The Relative Capacities of the two Bodies under the same Displacement affect the Form Forward and Aft.

THE immersed part of a ship, being a portion of the parallelopipodon formed by the three dimensions;—length on the load-water line, from the fore-side of the rabbet of the stem to the aft-side of the rabbet of the stern post; extreme breadth in midships of the load-water section; and the depth of immersion in midships from the lower edge of the rabbet of the keel;—it would seem that the first step towards the reduction

of the parallelopipodon, or oblong, into the required form, would be to find what portion of it would be of the same contents as the proposed displacement of the ship—a knowledge of which would enable the constructor, by a comparison of the result with a similar element of an approved ship, to determine whether the principal dimensions assumed would (under the form intended) give an immersed body equal to carrying the proposed weights or lading.

The relative capacities of the immersed bodies contained under the fore and after lengths of the load-water line must next be fixed, and the constructor in this very important element of a construction will find little to guide him from the results of past experience and practice. From deductions on approved ships of rival constructors it will be developed, that in this essential element, “the relative difference between the two bodies,” they vary from 1 to 13 per cent. on the whole displacement, and that in the system adopted by Sir William Symonds, the late Surveyor of the British Navy, where similarity of form was insisted upon, the range in this particular was from 3 to 13 per cent. on the whole displacement or volume immersed.

The relative capacities of the fore and after bodies of immersion under the proposed load-water line would seem at the first glance of the subject to be a fixed and determinate quantity, as being a conclusion easily arrived at from a knowledge of the proportions due to the superincumbent weights—under such a consideration the weight of the anchors, bowsprit, and foremast would necessarily be supposed to require an excess in the body immersed under the fore half-length of the load-water line over that immersed under the after half-length of the same element.

In a ship the necessary arrangement of the weights, to preserve the proposed relative immersion of the extremes or the intended draught of water, would be pointed out by a delineated curve of sectional areas, described as before directed; but a want of that system, or of some other, has often caused an

error in the actual draught of water, and that under a great relative excess of the volumes of displacement in the fore and after portions of the immersed body.

EXAMPLE.

The Men-of-war Brigs built in the year 1833 to a construction-draught of water of 12 ft. 9 in. forward, 14 ft. 4 in. abaft, giving 1 ft. 7 in. difference, had under such a construction a difference of displacement between the immersed bodies under the fore and after half-lengths of the load-water line that was equivalent to 10·4 tons for every 100 tons of the vessel's total displacement or weight; but these ships, when stowed and equipped for sea, came to the load-draught of water of 14 ft. 2 in. forward, 14 ft. 3 in. aft.—difference 1 in. or an immersion of the fore extreme of 18 in. more than was intended by the constructor: the reason of this practical departure from the proposed line of floatation of the constructor was, that the internal space or hold of the ship necessarily followed the external form, giving a hold proportionate to the displacement contained under the several portions of the body, but an injudicious disposal of the stores (in placing the weights too far forward) made them more than equivalent to the upward pressure of the water at the respective portions of the proposed immersion of the body, and thence arose the error or excess in the fore immersion by giving a greater draught of water than was designed. The stowage of a ship's hold, under a reference to the representative area for the displacement, contained between the curves of sectional areas developed for the light and load displacements, would prevent similar errors under any extent to which the relative capacity of the two bodies might be carried. This relative capacity of the two bodies will affect the form of the vessel's extremes, giving a short or long bow, a clear or full run to the rudder; for the whole displacement *being a fixed quantity*, if the portion of it under the fore half-length of the load-water line be increased, it must be followed, by a *proportionate diminution of the portion of the displacement under*

the after half-length of the load-water line, so that the total volume of the displacement may remain the same, which arrangement will give a proportionately full bow and clean run, and vice versâ.

PART VII.

Curve of Sectional Areas, applicable to the Comparison of the Relative Qualities of Ships of the same Rate, will give a Scale for Tonnage of Displacement under any Immersion.—Method of forming the Scale of Displacement.

THE curve of sectional areas under the foregoing considerations is also applicable to a comparison of the relative qualities of ships of the same rate, by showing at one view the distribution of the volume of displacement in each ship, under the draught of water which has been found on trial to give the greatest velocity, based on which, deductions may be made from the relative capacities of the bodies pointed out by the sectional curves, that will serve to guide the naval constructor in future constructions.

The curve of sectional areas is also available for forming a scale to measure the amount of displacement of a ship to any assumed or given draught of water. To effect this, on the sheer draught or longitudinal plan of the ship between the load-water line, or that of deepest immersion, and the line denoting the upper edge of the rabbet of the keel, drawing intermediate lines parallel to the load-water line as denoting lines of intermediate immersion between the keel and load-water line—these lines may be placed equidistant from each other, but they are not necessarily required to be so. Find the curve of sectional areas, due to each immersion of the ship denoted by these lines, and measure the areas bounded respectively by these curves, in the manner as before directed for the load displacement—these results will give the magni-

tudes of the immersed portions of the body in cubic feet, which being divided by 35, the mean of the number of cubic feet of salt or fresh water that are equivalent to a ton in weight will give their respective weights in tons.

Assume a line of scale for depth, or mean draught of water, the lower part of which is to be considered the underside of the false keel of the ship, and set off on this line, by means of a scale of parts, the depths of the immersions at the middle section of the longitudinal plan; draw lines (at the points thus obtained) perpendicular to this assumed line for depth or draught of water, and having determined a scale to denote the tons, set off on each line by this scale the tons ascertained by the curves of sectional areas to be due to the respective immersions of the body, then a curve passed through these points will be one on which the weights in tons due to the intermediate immersions of the body may be ascertained, or the displacement of a ship to the mean of a given draught may be found by setting up the mean depth on the scale, showing the draught of water—transferring that depth to the curve for tonnage, and then carrying the point thus obtained on the curve for tonnage to the scale of tons, which will give the number of tons of displacement to that depth of immersion or draught of water.

PART VIII.

Description of Fig. 8, or of the several Plans to be delineated by the Draughtsman, previous to the Commencement of the Calculations.

Sheer Plan.—A projection of the form of the vessel on a longitudinal and vertical plane, assumed to pass through the middle of the ship, and on which the position of any point in her may be fixed with respect to height and length.

Half-breadth Plan.—The form of the vessel projected on

to a longitudinal and horizontal plane, assumed to pass through the extreme length of ship, and on which the position of a point in the ship may be fixed for length and breadth.

Body Plan.—The forms of the vertical and athwartship sections of the ship, projected on to a vertical and athwartship plane, assumed to pass through the largest athwartship and vertical section of her, and on which plan the position of any point in the ship may be fixed for height and breadth.

These plans conjointly will determine every possible position required; for, by inspection it will be found—

That the sheer and half-breadth plans have

one dimension common to both, *viz.*: Length.

Half-breadth and body plane . . . Breadth.

Sheer and body plane . . . Height.

For sheer plan gives length and height .

Half-breadth plan gives length and breadth .

Body plan gives breadth and height .

} of the same
point.

Which dimensions form the co-ordinates for any point in the solid, and must determine the position of it.

The point *c* in the load-water section *A B*, of Fig. 8, has for its co-ordinates to fix its position,

The Length, 1.5 of the half-breadth plan.

Height, 5.*c* of the sheer plan,

And the breadth, 1.*c* of the body plan of section.

And the same for any other point of the solid or of the ship.

In the sheer plan, Fig. 8, *A B* represents the line of deepest immersion, *a a*, *b b*, *c c*, *d d*, lines drawn parallel to that line at a distance of 9 feet, making with *AB* an odd number of ordinates for the use of the first general rule for the area, where area = $\{A + 4 P + 2 Q\} \times \frac{r}{8}$, and *A* = the sum of the first and last ordinates.

P = the sum of the even ordinates, as 2, 4.

Q = the sum of the odd ordinates, as 3, &c.

The line A B, or length of the load-water line, is bisected at C, and A C, C B are thence equal; C being the middle point of the load-water line, the spaces B C, A C, are again divided into four equal divisions, giving five ordinates for each space, at a distance apart of 5.5 ft.

This arrangement will give the immersed body of the vessel, as being divided into two parts under an equal division of the load-water line, and an odd number of ordinates in each section of the body for the application of the first general rule given for finding the areas of the vertical sections and thence the displacement.

The half-breadth plan delineates the form of the body immersed for length and breadth, the line A B of the sheer plan being represented in the half-breadth plan by the line marked A B, and *a a*, *b b*, *c c*, *d d*, of the sheer plan by the lines similarly distinguished in the half-breadth plan.

The body plan gives the form of the body in the depth, the lines distinguished 5.5 in the sheer and half-breadth plans being in the body plan developed by the curve 5.5.5, giving the external form of the ship at the section 5.5, the same reasoning applies to the other divisions of the load-water line A B.

PART IX.

Application of Sterling's Rules to the Calculations required for the Construction Drawing of a Yacht of 36 tons, Old Measurement.—Fig. 8. 1st, Usual Mode of Calculating the Displacement by Vertical and Horizontal Sections.

FIG. 5.
5

				I K				
				1.1				
				2.2				
				3.3				
				4.4				

TABLE OF ORDINATES FOR YACHT OF 36 TONS.

Distinguishing No. of the Sections. } 1' A	1	2	3	4	(5)	6	7	8	9	r = equal to the distance between the ordinates used for the vertical section = .92 ft.
2' P	.35	2.4	4.2	5.6	5.6	5.5	4.4	2.6	.35	
3' Q	.3	1.7	3.2	4.4	5.0	4.6	3.4	1.7	.3	r = equal to the distance between the ordinates used for the horizontal sections = 5.5 ft.
4' P	.25	1.0	2.2	3.2	3.8	3.4	2.4	1.1	.25	
5' A	.2	.4	1.3	2.0	2.4	2.0	1.4	.6	.2	

From this table the following application of Sterling's rule, No. 1, is usually made to obtain the volume of displacement to the draught of water shown on the drawing as the load-water line or line of proposed deepest immersion, designated on Fig. 8, Plate A, as A B.

General terms of the rule :—

$$\text{Area} = \left\{ A + 4 P + 2 Q \right\} \times \frac{r}{3}$$

To find $\frac{1}{3}$ the area of Vertical Section 1, Fore Body :—

A = sum of the	.4	4 P = four times the sum of the	.35	
first and last	.2	even ordinates, or of (2)	.25	
	—	and (4)	.25	
	.6 = A		—	
	—		.60 = P	
			4.	
			—	
			2.4 = 4 P	

2 Q = twice the sum of the odd	.3 = Q		
ordinates, or of (3)	} × .2		
	—		
	.60 = 2 Q		

Whence the area, which is equal to

$$\left\{ A + 4 P + 2 Q \right\} \times \frac{r}{3} =$$

$$\left\{ .6 + 2.4 + .6 \right\} \times \frac{.92}{3}$$

$$3.6 \times \frac{.92}{3} = 1.2 \times .92 = 1.104 = \frac{1}{3} \text{ area of Section 1.}$$

Which sum is half the area of the Section 1, and is kept in that form of the half-measurement for the convenience of calculation.

FORE BODY.

Vertical Section 2.

$$\begin{array}{r} 3\cdot0 \\ \cdot4 \\ \hline 3\cdot4 = A \\ \hline \end{array}$$

$$\begin{array}{r} 2\cdot4 \\ 1\cdot0 \\ \hline 3\cdot4 = P \\ 4 \\ \hline \end{array}$$

$$\begin{array}{r} 1\cdot7 \\ 2 \\ \hline 3\cdot4 = 2 Q \\ \hline \end{array}$$

$$\begin{array}{r} 13\cdot6 = 4 P \\ 3\cdot4 = A \\ 3\cdot4 = 2 Q \\ \hline \end{array}$$

$$\begin{array}{r} 20\cdot4 = A + 4 P + 2 Q \\ \cdot92 = r \\ \hline \end{array}$$

$$\begin{array}{r} 408 \\ 1836 \\ \hline \end{array}$$

$$3)18\cdot768$$

$$\underline{6\cdot256} = \frac{1}{2} \text{ area of Section 2.}$$

Vertical Section 3.

$$\begin{array}{r} 5\cdot0 \\ 1\cdot3 \\ \hline 6\cdot3 = A \\ \hline \end{array}$$

$$\begin{array}{r} 4\cdot2 \\ 2\cdot2 \\ \hline 6\cdot4 = P \\ 4 \\ \hline \end{array}$$

$$\begin{array}{r} 3\cdot2 \\ 2 \\ \hline 6\cdot4 = 2 Q \\ \hline \end{array}$$

$$\begin{array}{r} 25\cdot6 = 4 P \\ 6\cdot3 = A \\ 6\cdot4 = 2 Q \\ \hline \end{array}$$

$$\begin{array}{r} 38\cdot3 = A + 4 P + 2 Q \\ \cdot92 = r \\ \hline \end{array}$$

$$\begin{array}{r} 766 \\ 3447 \\ \hline \end{array}$$

$$3)35\cdot236$$

$$\underline{11\cdot745} = \left\{ A + 4 P + 2 Q \right\} \times \frac{r}{3} = \frac{1}{2} \text{ area of Section 3.}$$

Vertical Section 4.

$$\begin{array}{r} 6\cdot0 \\ 2\cdot0 \\ \hline 8\cdot0 = A \\ \hline \end{array}$$

$$\begin{array}{r} 5\cdot6 \\ 3\cdot2 \\ \hline 8\cdot8 = P \\ 4 \\ \hline \end{array}$$

$$\begin{array}{r} 4\cdot4 \\ 2 \\ \hline 8\cdot8 = 2 Q \\ \hline \end{array}$$

$$\begin{array}{r} 35\cdot2 = 4 P \\ 8\cdot0 = A \\ 8\cdot8 = 2 Q \\ \hline \end{array}$$

$$\begin{array}{r} 52\cdot0 = A + 4 P + 2 Q \\ \cdot92 = r \\ \hline \end{array}$$

$$\begin{array}{r} 1040 \\ 4680 \\ \hline \end{array}$$

$$3)47\cdot840$$

$$\underline{15\cdot946} = \{ A + 4 P + 2 Q \} \times \frac{r}{3} = \left\{ \frac{1}{3} \text{ area of Section 4} \right\}$$

Vertical Section 5.

$$\begin{array}{r} 6\cdot3 \\ 2\cdot4 \\ \hline 8\cdot7 = A \\ \hline \end{array}$$

$$\begin{array}{r} 5\cdot6 \\ 3\cdot8 \\ \hline 9\cdot4 = P \\ 4 \\ \hline \end{array}$$

$$\begin{array}{r} 5\cdot0 \\ 2 \\ \hline 10\cdot0 = 2 Q \\ \hline \end{array}$$

$$\begin{array}{r} 37\cdot6 = 4 P \\ 8\cdot7 = A \\ 10\cdot0 = 2 Q \\ \hline \end{array}$$

$$\begin{array}{r} 56\cdot3 = \{ A + 4 P + 2 Q \} \\ \cdot92 = r \\ \hline \end{array}$$

$$\begin{array}{r} 1126 \\ 5067 \\ \hline \end{array}$$

$$3)51\cdot796$$

$$\underline{17\cdot265} = \{ A + 4 P + 2 Q \} \times \frac{r}{3} = \left\{ \frac{1}{3} \text{ area of Section 5.} \right\}$$

Half areas of Vertical Sections, 1, 2, 3, 4, and 5.

No. 1	.	.	.	1·104 ft.
2	.	.	.	6·256
3	.	.	.	11·745
4	.	.	.	15·946
5	.	.	.	17·265

Displacement of the body under the fore half-length of the load-water line by the vertical sections, or the summation of the vertical areas, 1, 2, 3, 4, and 5, by the formula for the solid, as being equal to

$$\left\{ A' + 4P' + 2Q' \right\} \times \frac{r'}{3} \quad \text{where } A' = \text{sum of 1st and 5th areas.}$$

$$P' = \quad \text{,,} \quad \text{2nd and 4th areas.}$$

$$Q' = \quad \text{,,} \quad \text{3rd area.}$$

And r' = distance between the vertical sections, or 5·5 ft.

1. .. 1·104	2. .. 6·256	3. .. 11·745 = Q'
5. .. 17·265	4. .. 15·946	2
18·369 = A'	22·202 = P'	23·490 = 2Q'
	4	
	88·808 = 4 P'	
	18·369 = A'	
	23·490 = 2 Q'	
	130·667 = A' + 4 P' + 2 Q'	
	5·5 = r'	
	653335	
	653335	
	3)718·6685	
	239·556 = A' + 4 P' + 2 Q' × $\frac{r'}{3}$ = cubic feet	of space in
	2	half fore-body.
	479·112 = cubic feet of space in fore body.	

Displacement of the body immersed under the after half-length of the load-water line by the vertical areas 5, 6, 7, 8, and 9 of the table of ordinates.

Vertical Section 6.

5, as Fore Body.	6·1	5·5	4·6 = Q
17·265	2·0	3·4	2
	<hr style="width: 50px; margin: 0 auto;"/>	<hr style="width: 50px; margin: 0 auto;"/>	<hr style="width: 50px; margin: 0 auto;"/>
	8·1 = A	8·9 = P	9·2 = 2 Q
	<hr style="width: 50px; margin: 0 auto;"/>	4	<hr style="width: 50px; margin: 0 auto;"/>
		35·6 = 4 P	
		8·1 = A	
		9·2 = 2 Q	
		<hr style="width: 50px; margin: 0 auto;"/>	
		52·9 = A + 4 P + 2 Q	
		·92 = r	
		<hr style="width: 50px; margin: 0 auto;"/>	
		1058	
		4761	
		<hr style="width: 50px; margin: 0 auto;"/>	
		3)48·668	
		<hr style="width: 50px; margin: 0 auto;"/>	
		16·222 = A + 4 P + 2 Q × $\frac{r}{3}$ = { $\frac{1}{3}$ area of	Section 6.

Vertical Section 7.

5·4	4·4	3·4 = Q
1·4	2·4	2
<hr style="width: 50px; margin: 0 auto;"/>	<hr style="width: 50px; margin: 0 auto;"/>	<hr style="width: 50px; margin: 0 auto;"/>
6·8 = A	6·8 = P	6·8 = 2 Q
<hr style="width: 50px; margin: 0 auto;"/>	4	<hr style="width: 50px; margin: 0 auto;"/>
	27·2 = 4 P	
	6·8 = 2 Q	
	6·8 = A	
	<hr style="width: 50px; margin: 0 auto;"/>	
	40·8 = A + 4 P + 2 Q	
	·92 = r	
	<hr style="width: 50px; margin: 0 auto;"/>	
	816	
	3672	
	<hr style="width: 50px; margin: 0 auto;"/>	
	3)37·536	
	<hr style="width: 50px; margin: 0 auto;"/>	
	12·512 = A + 4 P + 2 Q × $\frac{r}{3}$ = { $\frac{1}{3}$ area of	Section 7.

Vertical Section 8.

$\begin{array}{r} 3\cdot7 \\ \cdot6 \\ \hline 4\cdot3 = A \\ \hline \end{array}$	$\begin{array}{r} 2\cdot6 \\ 1\cdot1 \\ \hline 3\cdot7 = P \\ 4 \\ \hline 14\cdot8 = 4 P \\ 4\cdot3 = A \\ 3\cdot4 = 2 Q \\ \hline 22\cdot5 = A + 4 P + 2 Q \\ \cdot92 = r \\ \hline 450 \\ 2025 \\ \hline 3)20\cdot700 \\ \hline 6\cdot9 \end{array}$	$\begin{array}{r} 1\cdot7 = Q \\ 2 \\ \hline 3\cdot4 = Q \\ \hline \end{array}$
--	--	---

$$6\cdot9 = A + 4 P + 2 Q \times \frac{r}{3} = \left\{ \frac{1}{3} \text{ area of Section 8.} \right.$$

Vertical Section 9.

$\begin{array}{r} \cdot4 \\ \cdot2 \\ \hline \cdot6 = A \\ \hline \end{array}$	$\begin{array}{r} \cdot35 \\ \cdot25 \\ \hline \cdot60 = P \\ 4 \\ \hline 2\cdot4 = 4 P \\ \cdot6 = A \\ \cdot6 = 2 Q \\ \hline 3\cdot6 = A + 4 P + 2 Q \\ \cdot92 = r \\ \hline 72 \\ 324 \\ \hline 3)3\cdot312 \\ \hline 1\cdot104 \end{array}$	$\begin{array}{r} \cdot3 = Q \\ 2 \\ \hline \cdot6 = 2 Q \\ \hline \end{array}$
--	---	---

$$1\cdot104 = A + 4 P + 2 Q \times \frac{r}{3} = \frac{1}{3} \text{ area of Section 9.}$$

Half areas of the vertical sections 5, 6, 7, 8, and 9.

Sections.	Areas.
5. . . .	17·265
6. . . .	16·22
7. . . .	12·512
8. . . .	6·9
9. . . .	1·104

Displacement of the after body under the after half-length of the load-water line by the vertical sections or the summation of the immersed areas of the vertical sections 5, 6, 7, 8, and 9 by the formula for the solid as being equal to

$$\frac{A' + 4 P' + 2 Q'}{3} \times \frac{r'}{3}$$

where A' = sum of the 5th and 9th areas.
 P' = „ 6th and 8th areas.
 Q' = „ 7th area.

and r' = the distance between the vertical sections, or 5·5 ft.

5. . . 17·265	6. . . 16·22	7. . . 12·512 = Q'
9. . . 1·104	8. . . 6·900	2
<hr/>	<hr/>	<hr/>
18·369 = A'	23·120 = P'	25·024 = $2Q'$
	4	
	<hr/>	
	92·480 = $4P'$	
	25·024 = $2Q'$	
	18·369 = A'	
	<hr/>	
	135·873 = $A' + 4P' + 2Q'$	
	5·5 = r	
	<hr/>	
	679·365	
	67·936	
	<hr/>	
	3)747·3015	
	<hr/>	
	249·1005 = $\frac{A' + 4P' + 2Q'}{3} \times \frac{r'}{3}$	
	2 Cubic ft. in $\frac{1}{3}$ after body	
	<hr/>	
	498·2010 After body in cubic ft. of space.	
	<hr/>	

Displacement of Fore Body by Horizontal Sections.

Horizontal Section 1'.

$\begin{array}{r} 0.4 \\ 6.3 \\ \hline 6.7 = A' \\ \hline \end{array}$	$\begin{array}{r} 6.0 \\ 3.0 \\ \hline 9.0 = P \\ 4 \\ \hline 36.00 = 4 P \\ 10.00 = 2 Q \\ 6.70 = A \\ \hline 52.70 = A + 4 P + 2 Q \\ 5.5 = r \\ \hline 2635 \\ 2635 \\ \hline 3)289.85 \\ \hline 96.61 A + 4 P + 2 Q \times \frac{r}{3} = \left\{ \frac{1}{3} \text{ area of Section 1'.} \right. \end{array}$	$\begin{array}{r} 5.0 = Q \\ 2 \\ \hline 10.0 = Q \\ \hline \end{array}$
--	---	--

Horizontal Section 2'.

$\begin{array}{r} .35 \\ 5.60 \\ \hline 5.95 = A \\ \hline \end{array}$	$\begin{array}{r} 5.7 \\ 2.4 \\ \hline 8.1 = P \\ 4 \\ \hline 32.4 = 4 P \\ 8.4 = 2 Q \\ 5.95 = A \\ \hline 46.75 = A + 4 P + 2 Q \\ 5.5 = r \\ \hline 23375 \\ 23375 \\ \hline 3)257.125 \\ \hline 85.708 = \left\{ A + 4 P + 2 Q \right\} \times \frac{r}{3} = \left\{ \frac{1}{3} \text{ area of Section 2'.} \right. \end{array}$	$\begin{array}{r} 4.2 = Q \\ 2 \\ \hline 8.4 = 2 Q \\ \hline \end{array}$
---	---	---

Horizontal Section 3'.

$\begin{array}{r} \cdot 3 \\ 5 \cdot 0 \\ \hline 5 \cdot 3 = A \end{array}$	$\begin{array}{r} 4 \cdot 4 \\ 1 \cdot 7 \\ \hline 6 \cdot 1 = P \\ 4 \\ \hline 24 \cdot 4 = 4 P \\ 5 \cdot 3 = A \\ 6 \cdot 4 = 2 Q \\ \hline 36 \cdot 1 = A + 4 P + 2 Q \\ 5 \cdot 5 = r \\ \hline 1805 \\ 1805 \\ \hline 3)198 \cdot 55 \end{array}$	$\begin{array}{r} 3 \cdot 2 = Q \\ 2 \\ \hline 6 \cdot 4 = 2 Q \end{array}$
$\underline{66 \cdot 18} = A + 4 P + 2 Q \times \frac{r}{3} = \frac{1}{2} \text{ area of Section 3'}$		

Horizontal Section 4'.

$\begin{array}{r} \cdot 25 \\ 3 \cdot 8 \\ \hline 4 \cdot 05 = A \end{array}$	$\begin{array}{r} 3 \cdot 2 \\ 1 \cdot 0 \\ \hline 4 \cdot 2 = P \\ 4 \\ \hline 16 \cdot 8 = 4 P \\ 4 \cdot 05 = A \\ 4 \cdot 40 = 2 Q \\ \hline 25 \cdot 25 = A + 4 P + 2 Q \\ 5 \cdot 5 = r \\ \hline 12625 \\ 12625 \\ \hline 3)138 \cdot 875 \end{array}$	$\begin{array}{r} 2 \cdot 2 = Q \\ 2 \\ \hline 4 \cdot 4 = 2 Q \end{array}$
$\underline{46 \cdot 291} = A + 4 P + 2 Q \times \frac{r}{3} = \left\{ \begin{array}{l} \frac{1}{2} \text{ area of} \\ \text{Section 4'} \end{array} \right.$		

Horizontal Section 5'.

$\begin{array}{r} \cdot 2 \\ 2 \cdot 4 \\ \hline 2 \cdot 6 = A \\ \hline \end{array}$	$\begin{array}{r} 2 \cdot 0 \\ \cdot 4 \\ \hline 2 \cdot 4 = P \\ 4 \\ \hline 9 \cdot 6 = 4 P \\ \cdot 2 \cdot 6 = A \\ 2 \cdot 6 = 2 Q \\ \hline 14 \cdot 8 = A + 4 P + 2 Q \\ 5 \cdot 5 = r \\ \hline 740 \\ 740 \\ \hline 3)81 \cdot 40 \\ \hline 27 \cdot 13 = \left\{ A + 4 P + 2 Q \right\} \times \frac{r}{3} = \frac{1}{3} \text{ area of Section 5'}. \end{array}$	$\begin{array}{r} 1 \cdot 3 = Q \\ 2 \\ \hline 2 \cdot 6 = 2 Q \\ \hline \end{array}$
---	---	---

Displacement of the fore body under the fore half-length of the load-water line by horizontal sections, or the summation of the horizontal sections of the fore body 1', 2', 3', 4', and 5', by the formula for the solid, as being equal to

$$\left\{ A' + 4 P' + 2 Q' \right\} + \frac{r}{3};$$

where

- A' = sum of the 1'st and 5'th areas;
- P' = " " " 2'nd and 4'th areas;
- Q' = " " " 3'rd area;

and r = the distance between the horizontal sections or .92 ft.,

Half areas of the Horizontal Sections 1', 2', 3', 4', and 5'.

- 1' = 96.61.
- 2' = 85.708.
- 3' = 66.18.
- 4' = 46.29.
- 5' = 27.13.

<p>Areas. 1'... 96·61 5'... 27·13</p> <hr style="width: 50%; margin-left: 0;"/> <p>123·74 = A'</p>	<p>Areas. 2'... 85·708 4'... 46·290</p> <hr style="width: 50%; margin-left: 0;"/> <p>131·998 = P'</p> <hr style="width: 50%; margin-left: 0;"/> <p>527·992 = 4 P'</p> <p>123·740 = A'</p> <p>132·360 = 2 Q'</p> <hr style="width: 50%; margin-left: 0;"/> <p>784·092 = A' + 4 P' + 2 Q'</p> <p style="margin-left: 100px;">·92 = r</p> <hr style="width: 50%; margin-left: 0;"/> <p>1568184</p> <p>7056828</p> <hr style="width: 50%; margin-left: 0;"/> <p>3)721·36464</p> <hr style="width: 50%; margin-left: 0;"/> <p>240·45 = { A' + 4 P' + 2 Q' } × $\frac{r}{3}$ = cubic ft. in 2 ½ fore body.</p> <hr style="width: 50%; margin-left: 0;"/> <p>480·90 = fore body by horizontal sections in cubic feet of space.</p>	<p>Areas. 3'... 66·18 = Q'</p> <hr style="width: 50%; margin-left: 0;"/> <p>132·36 = 2 Q'</p>
--	---	---

Displacement, by Horizontal Sections of the body immersed under the after half-length of the load-water line, or by the horizontal areas 1', 2', 3', 4', and 5', of the table of ordinates.

Calculated areas of 1', 2', 3', 4', and 5'.

Section 1' After Body.

<p>6·3 ·4</p> <hr style="width: 50%; margin-left: 0;"/> <p>6·7 = A</p>	<p>6·1 3·7</p> <hr style="width: 50%; margin-left: 0;"/> <p>9·8 = P</p> <hr style="width: 50%; margin-left: 0;"/> <p>39·2 = 4 P</p> <p>10·8 = 2 Q</p> <p>6·7 = A</p> <hr style="width: 50%; margin-left: 0;"/> <p>56·7 = A + 4 P + 2 Q</p> <p style="margin-left: 100px;">5·5 = r</p> <hr style="width: 50%; margin-left: 0;"/> <p>2835</p> <p>2835</p> <hr style="width: 50%; margin-left: 0;"/> <p>3)311·85</p> <hr style="width: 50%; margin-left: 0;"/> <p>103·95 = $\frac{\text{Area of Section 1'}}{3} = \left\{ \frac{1}{3} \text{ area of Section 1'}. \right.$</p>	<p>5·4 = Q</p> <hr style="width: 50%; margin-left: 0;"/> <p>10·8 = 2 Q</p>
--	--	--

Section 2' After Body.

$$\begin{array}{r} 5\cdot6 \\ -35 \\ \hline 5\cdot95 = A \\ \hline \end{array}$$

$$\begin{array}{r} 5\cdot5 \\ 2\cdot6 \\ \hline 8\cdot1 = P \\ 4 \\ \hline \end{array}$$

$$\begin{array}{r} 4\cdot4 = Q \\ 2 \\ \hline 8\cdot8 = 2 Q \\ \hline \end{array}$$

$$\begin{array}{r} 23\cdot40 = 4 P \\ 5\cdot95 = A \\ 8\cdot80 = 2 Q \\ \hline \end{array}$$

$$\begin{array}{r} 47\cdot15 = A + 4 P + 2 Q \\ 5\cdot5 = r' \\ \hline \end{array}$$

$$\begin{array}{r} 23575 \\ 23575 \\ \hline \end{array}$$

$$3)259\cdot325$$

$$\underline{\underline{86\cdot441}} = \underline{\underline{A + 4 P + 2 Q}} \times \frac{r'}{3} = \left\{ \frac{1}{3} \text{ area of Section 2'}. \right.$$

Section 3' After Body.

$$\begin{array}{r} 5\cdot0 \\ \cdot3 \\ \hline 5\cdot3 = A \\ \hline \end{array}$$

$$\begin{array}{r} 4\cdot6 \\ 1\cdot7 \\ \hline 6\cdot3 = P \\ 4 \\ \hline \end{array}$$

$$\begin{array}{r} 3\cdot4 = Q \\ 2 \\ \hline 6\cdot8 = 2 Q \\ \hline \end{array}$$

$$\begin{array}{r} 25\cdot2 = 4 P \\ 5\cdot3 = A \\ 6\cdot8 = 2 Q \\ \hline \end{array}$$

$$\begin{array}{r} 37\cdot3 = A + 4 P + 2 Q \\ 5\cdot5 = r \\ \hline \end{array}$$

$$\begin{array}{r} 1865 \\ 1865 \\ \hline \end{array}$$

$$3)205\cdot15$$

$$\underline{\underline{68\cdot38}} = \underline{\underline{A + 4 P + 2 Q}} \times \frac{r'}{3} = \left\{ \frac{1}{3} \text{ area of Section 3'}. \right.$$

Section 4' After Body.

$$\begin{array}{r} 3\cdot8 \\ \cdot25 \\ \hline 4\cdot05 = A \\ \hline \end{array}$$

$$\begin{array}{r} 3\cdot4 \\ 1\cdot1 \\ \hline 4\cdot5 = P \\ 4 \end{array}$$

$$\begin{array}{r} 2\cdot4 = Q \\ 2 \\ \hline 4\cdot8 = 2 Q \\ \hline \end{array}$$

$$\begin{array}{r} 18\cdot00 = 4 P \\ 4\cdot05 = A \\ 4\cdot80 = 2 Q \\ \hline \end{array}$$

$$\begin{array}{r} 26\cdot85 = A + 4 P + 2 Q \\ 5\cdot5 = r' \\ \hline \end{array}$$

$$\begin{array}{r} 13425 \\ 13425 \\ \hline \end{array}$$

$$3)147\cdot675$$

$$\underline{\underline{49\cdot225}} = \underline{\underline{A + 4 P + 2 Q}} \times \frac{r'}{3} = \left\{ \frac{1}{3} \text{ area of Section 4'}. \right.$$

Section 5' After Body.

$$\begin{array}{r} 2\cdot4 \\ \cdot2 \\ \hline 2\cdot6 = A \\ \hline \end{array}$$

$$\begin{array}{r} 2\cdot0 \\ \cdot6 \\ \hline 2\cdot6 = P \\ 4 \end{array}$$

$$\begin{array}{r} 1\cdot4 = Q \\ 2 \\ \hline 2\cdot8 = 2 Q \\ \hline \end{array}$$

$$\begin{array}{r} 10\cdot4 = 4 P \\ 2\cdot8 = 2 Q \\ 2\cdot6 = A \\ \hline \end{array}$$

$$\begin{array}{r} 15\cdot8 = A + 4 P + 2 Q \\ 5\cdot5 = r' \\ \hline \end{array}$$

$$\begin{array}{r} 790 \\ 790 \\ \hline \end{array}$$

$$3)86\cdot90$$

$$\underline{\underline{28\cdot96}} = \left\{ A + 4 P + 2 Q \right\} \times \frac{r'}{3} = \left\{ \frac{1}{3} \text{ area of Section 5'}. \right.$$

Displacement by horizontal sections of the after body under the after half-length of the load-water line, or the summation of the horizontal sections of the after body, 1', 2', 3', 4', and 5', by the formula of the solid, as being equal to

$$\left\{ A' + 4 P' + 2 Q' \right\} \times \frac{r'}{3}.$$

Half areas of the After Horizontal Sections, .

1', 2', 3', 4', and 5'.

Sections.	Areas.
1'	103·95.
2'	86·44.
3'	68·38.
4'	49·22.
5'	28·96.

Areas.	Areas.	Areas.
1' . . . 103·95	2' . . . 86·44	3' . . . 68·38 = Q'
5' . . . 28·96	4' . . . 49·22	2
132·91 = A'	135·66 = P'	136·76 = 2 Q'

$$\begin{aligned} 542·64 &= 4 P' \\ 132·91 &= A' \\ 136·76 &= 2 Q' \end{aligned}$$

$$\begin{aligned} 812·31 &= A' + 4 P' + 2 Q' \\ \cdot 92 &= r \end{aligned}$$

$$\begin{aligned} 162462 \\ 731079 \end{aligned}$$

$$3)747·3252$$

$$\frac{249·1084}{2} = \left\{ A' + 4 P' + 2 Q' \right\} \times \frac{r'}{3} = \text{cubic feet in half-after body by horizontal sections.}$$

$$\frac{498·2168}{2} = \text{After body by horizontal sections in cubic feet of space.}$$

DISPLACEMENT.

By Vertical Sections.	Cubic Ft.	By Horizontal Sections.	Cubic Ft.
Fore body (p. 29)	479·11	Fore body (p. 36)	480·900
After body (p. 32)	498·20	After body (p. 39)	498·216
	<hr style="width: 100%;"/>		<hr style="width: 100%;"/>
Sum	977·30	Sum	979·116
	<hr style="width: 100%;"/>		<hr style="width: 100%;"/>
Half	488·65	Half	489·558
	<hr style="width: 100%;"/>		<hr style="width: 100%;"/>
		Cubic Ft.	
		By Horizontal Sections . . .	979·116
		By Vertical Sections . . .	977·300
			<hr style="width: 100%;"/>
		Difference . . .	1·816 cubic feet.
Cubic Ft.			<hr style="width: 100%;"/>
			979·49 = capacity or displacement in cubic feet of space.

The mean weight of salt and fresh water gives 35 cubic feet of space when filled with water, to be equivalent to a ton avoirdupois; thence the displacement in cubic feet of space being divided by 35 will give the weight of the volume displaced in tons avoirdupois; or 979·49 being divided by 35 gives

$$5)979\cdot49$$

$$\underline{7)195\cdot898}$$

27·985 Tons, the weight of the calculated

immersed body in tons.

PART X.

By the usual Method.—Area of Midship or greatest Transverse Section.—Area of the Load-water Line, or Area of the assumed Plane of Deepest Immersion.—Capacity to the Inch at that Immersion in Cubic Feet, and Tons of 35 Cubic Feet of Space.—Longitudinal Distance of the Centre of Gravity of Displacement from Section 1, considered as the Initial Plane.—Distance the Centre of Gravity is below the Load-water Line, or Line of assumed Deepest Immersion.—Distance of the Centre of Gravity of the Load-water Section from the Section 1 of Fig. 8.

AREA OF THE MIDSHIP SECTION, OR OF THE GREATEST TRANSVERSE SECTION OF FIG. 8.

Section at 5.

$\begin{array}{r} 1.1. \dots 6.3 \\ 5.5. \dots \cdot 2 \\ \hline 6.5 = A \\ \hline \end{array}$	$\begin{array}{r} 2.2. \dots 6.0 \\ 4.4. \dots 2.3 \\ \hline 8.3 = P \\ \hline 4 \\ \hline 33.2 = 4 P \\ 6.5 = A \\ 9.6 = 2 Q \\ \hline 49.3 = A + 4 P + 2 Q \\ 1.25 = \frac{r}{3} \text{ where } r = \text{the depth, from 1 to 5,} \\ \text{divided by 4} = 5 \text{ ft.} \\ \text{by 4} = 1.25 \text{ ft.} \\ \hline 2465 \\ 986 \\ 493 \\ \hline 3)61.625 \\ \hline 20.541 = \left\{ A + 4P + 2Q \right\} \times \frac{r}{3} = \frac{1}{3} \text{ area of mid-} \\ \text{ship section.} \\ \hline 41.082 = \text{Area of midship section without keel.} \\ \hline \end{array}$	$\begin{array}{r} 3.3. \dots 4.8 = Q \\ \hline 2 \\ \hline 9.6 = 2 Q \\ \hline \end{array}$
---	--	---

LOAD-WATER LINE.

Area of the load-water line or area of the assumed deepest plane of immersion, delineated in Fig. 8, Plate A, on the half-

breadth Plan, and marked by the curve A B. From the Table of Ordinates, p. 26, we have—

.4	3.0	5.0
.4	6.0	6.3
—	6.1	5.4
.8 = A	3.7	—
—	—	16.7 = Q
	18.8 = P	2
	4	—
	—	33.4 = 2 Q
	75.2 = 4 P	—
	.8 = A	
	33.4 = 2 Q	
	—	
	109.4 = A + 4 P + 2 Q	
	5.5 = r'	
	—	
	5470	
	5470	
	—	
	3)601.70	
	—	
	200.56 = { A + 4 P + 2 Q } × $\frac{r'}{3}$ = $\frac{1}{2}$ area of load-water line.	

200.56 = $\frac{1}{2}$ area of load-water section in superficial feet.

2

401.12 = area of load-water section, which amount of area being divided by 12, will give the number of cubic feet of space that would be contained in a zone of that area of an inch in depth, and that result being again divide by 35, as the number of cubic feet of water equivalent to a ton in weight, will give the number of tons that will immerse the vessel one inch at that line of immersion.

Example.

12)401.12 = area of Load-water Section in superficial feet.

5)33.42 = cubic feet in zone of one inch in depth.

7)6.684

—
 .955 = tons to the inch of immersion at the load-water line.

CENTRE OF GRAVITY OF THE DISPLACEMENT.

Estimated from Section 1, considered as the Initial Plane.

Distinguishing No. of the Areas.	Vertical Areas.	Moments.
From p. 28, From p. 29.	1. .. 1.104 × 0	000.000
	2. .. 6.256 × 1	6.256
	3. .. 11.745 × 2	23.490
	4. .. 16.069 × 3	48.207
	5. .. 17.265 × 4	69.060
From p. 29.	6. .. 16.222 × 5	81.110
	7. .. 12.512 × 6	75.072
	8. .. 6.900 × 7	48.300
	9. .. 1.104 × 8	8.832

Moments placed in the Rule.

$$\text{Sum.} = \left\{ A + 4 P + 2 Q \right\} \times \frac{r'}{3}$$

000.000	6.256	23.490
8.832	48.207	69.060
<hr/>	81.110	75.072
8.832 = A	48.300	<hr/>
	183.873 = P	167.622 = Q
	4	2
	<hr/>	<hr/>
	735.492 = 4 P	335.244 = 2 Q
	8.832 = A	
	335.244 = 2 Q	
	<hr/>	
	1079.568 = A + 4 P + 2 Q	
	5.5 = r'	
	<hr/>	
	5397840	
	5397840	
	<hr/>	
	3)5937.6240	
	<hr/>	
	1979.208 = $\left\{ A + 4 P + 2 Q \right\} \frac{r'}{3} =$	

sum of the moments of half the displacement from section 1, in intervals of space of 5.5 ft. ; and the half displacement in cubic feet by vertical sections is 488.650 (p. 40) cubic ft. ; whence it is found, by dividing the moment 1979.208 by 488.650, that the distance of the centre of gravity of displacement from the section 1 is as follows :—

488·65) 1979·208 (4·05 intervals from 1.
195460 interval = 5·5 ft.

246080
244325

1755 therefore $4\cdot05 \times 5\cdot5 = 22\cdot27$ ft. =
distance of the centre of gravity of the
calculated immersed body from 1.

DEPTH OF THE CENTRE OF GRAVITY OF THE DISPLACEMENT BELOW THE LOAD-WATER SECTION.

Fore Body. After Body.

Section.	Areas.	Areas.	Sum of the Areas.	Moments.
1'	96·61	103·95 . . .	200·56	$\times 0 = 000\cdot000$
2'	85·708	86·44 . . .	172·148	$\times 1 = 172\cdot148$
3'	66·18	68·38 . . .	134·56	$\times 2 = 269\cdot12$
4'	46·29	49·22 . . .	95·51	$\times 3 = 286\cdot53$
5'	27·13	28·96 . . .	56·09	$\times 4 = 224\cdot36$
000·00		172·148		269·12 = Q
·224·36		286·530		2
<u>224·36 = A</u>		<u>458·678 = P</u>		<u>538·24 = 2 Q</u>
		4		
		1834·712 = 4 P		
		224·360 = A		
		538·240 = 2 Q		
		<u>2597·312 = { A + 4 P + 2 Q }</u>		
		·92 = r		
		<u>5194624</u>		
		<u>23375808</u>		
		3)2389·52704		
		<u>796·509 = { A + 4 P + 2 Q }</u>		$\times \frac{r}{3} =$

sum of the moments of the half displacement calculated from the load-water line: the half displacement by horizontal sections is 489·588 (p. 40) cubic feet; the sum of the moments of the half displacement 796·509 ft., being divided by that quantity, will give the distance in intervals of ·92 ft., the centre of gravity of displacement is below the load-water line.

Half solid of

displacement. Moments.

489·558) 796·509 (1·62 intervals of ·92 ft. ; therefore

489558	1·62
3069510	x ·92
2937348	324
1321620	1458

979116

342504

1·4904 ft. = the distance the centre of gravity of the calculated immersed body is below the load-water section.

DISTANCE OF THE CENTRE OF GRAVITY OF THE AREA OF THE LOAD-WATER SECTION FROM SECTION 1.

No. of Section.	Ordinates of Section 1 from the Table, p. 26.	Distances of them in intervals of 5·5 ft. from Section 1.	Moments, being the Product of the Areas by the respective Distances.
1	·4	0	000·00
2	3·0	1	3·0
3	5·0	2	10·0
4	6·0	3	18·0
5	6·3	4	25·2
6	6·1	5	30·5
7	5·4	6	32·4
8	3·7	7	25·9
9	·4	8	3·2

The moments, for summation, put into the rule.

00·0	3·0	10·0
3·2	18·0	25·2
3·2 = A	30·5	32·4
	25·9	67·6 = Q
	77·4 = P	2
	4	135·2 = 2 Q
	309·6 = 4 P	
	3·2 = A	
	135·2 = 2 Q	
	448·0 = A + 4 P + 2 Q	
	5·5 = r'	
	2240	
	2240	
	3)2464·0	
	821·3 = { A + 4 P + 2 Q } × $\frac{r'}{3}$ =	

sum of the moments of the half area of the load-water section reckoned from 1 ; the half area of the load-water section is 200·56 feet (p. 42) ; the distance, therefore, of the centre of gravity of the load-water section from 1 will be found in intervals of space of 5·5 feet, by dividing the sum of these moments by the half area, thus :—

Half Area.	Moments.	No.
200·56)	821·3333	(4·09 intervals, each
	80224	5·5 ft. in length.
	190933	
	180504	
	10429	

and $4\cdot09 \times 5\cdot5 = 22\cdot5$ ft. gives the distance of the centre of gravity of the load-water section from section 1 of the drawing.

PART XI.

By the usual Method.—Relative Capacity of the Bodies immersed under the Fore and After Lengths of the Load-water Line.—Per Centage of the Bodies.—Height of the Metacentre as the Comparative Measure of the Stability or Stiffness under Canvas of Vessels of the same dimensions.—Summary of the Results of the Calculations.

RELATIVE capacities of the bodies immersed under the fore and after lengths of equal division of the load-water line—

By former calculations.

After body immersed contains .	497·79	cubic ft. of space.
Fore body ,, ,, .	481·70	cubic ft. of space.
	Difference	16·09 =

the excess in cubic feet of space of the body displaced under the after half-length of the load-water line over that under the fore-half of the same line—

Sum of the bodies (by former calculation) or whole }
displacement in cubic feet of space (p. 40). } 979·49

equal to 9·7949 hundreds of cubic feet of space, whence 16·09,

or the difference between the two bodies in cubic feet, being divided by 9·7949, or the displacement expressed in terms of the hundreds of cubic feet of space, will give the excess for every hundred cubic feet of the whole displacement.

Displacement in Hundreds of Cubic Feet of Space.	Excess in Cubic Feet of Space.	
9·7949)	16·09000	(1·6 = Ratio of the excess of the after body of dis- placement over the fore body of the same, de- noted by a per centage of the whole displace- ment.
	97949	
	629510	
	587694	
	·41816	

METACENTRE.

A Measure of the comparative Stability of a Ship, or the Height of the Metacentre above the Centre of Gravity of displacement estimated, from the expression $\frac{2}{3} \int \frac{y^3 dx}{D}$, in which

y = The ordinates of the half-breadth load-water section.

dx = The fluxional increment of the length of the load-water section.

D = Displacement of the immersed portion of the body in cubic feet of space.

	Ordinates from the Table.	Cubes of the Ordinates.
Page 26.	·4	00·064
	3·0	27·000
	5·0	125·000
	6·0	216·000
	6·3	250·047
	6·1	226·981
	5·4	157·464
	3·7	50·653
	·4	0·064

Cubes placed in Sterling's Rule for Summation of

$$\text{Area} = (A + 4P + 2Q) \times \frac{r}{3}$$

00·064	27·000	125·000
00·064	216·000	250·047
00·064	226·981	157·464
·128 = A	50·653	
	520·634 = P	532·511 = Q
	4	2
	2082·536 = 4 P	1065·022 = 2 Q
	1065·022 = 2 Q	
	000·128 = A	
	3147·686 = { A + 4 P + 2 Q }	
	5·5 = r'	
	15738430	
	15738430	
	3)17312·2730	
	5770·7576 = { A + 4 P + 2 Q } \times \frac{r'}{3} =	

summation of the cubes of the ordinates of the load-water section; and the height of the Metacentre above the centre of gravity of Displacement is expressed by $\frac{2}{3} \int \frac{y^3 dx}{D}$, in which expression $y^3 dx = 5770·75$ and $D = 979·1$ (p. 40) whence $\frac{2}{3} \times \frac{5770·75}{979·1} = 3·98$ feet is the height of the Metacentre above the centre of gravity of the Displacement.

RESULTS OF THE CALCULATIONS.

1st Method.

Displacement in Cubic Feet of Space . . .	= 979·149.
Displacement in Tons of 35 Cubic Feet of Water to a Ton	} = 27·974.
Area of Midship Section	= 41·08 superficial feet.
Area of Load-water Line or Plane at the proposed deepest Immersion	} = 401·12 superficial feet.
Tons to one inch of Immersion at that Floatation	} = ·955 tons.
Longitudinal Distance of the Centre of Gravity of Displacement from Sec- tion 1, Fig. 8.	} = 22·22 feet.
Depth of the Centre of Gravity of Dis- placement below the Load-water Sec- tion	} = 1·4904 feet.
Distance of the Centre of Gravity of the Load-water Section from Vertical Sec- tion 1	} = 22·5 feet.
Relative capacity of the After Body in excess of the Fore Body in Cubic Feet of Space	} = 16·09.
Per Centage on the whole Displacement .	= 1·6.
Height of the Metacentre above the Centre of Gravity of Displacement, estimated from the expression $\frac{2}{3} \int \frac{y^3 dx}{D}$	} = 3·98 feet.

PART XII.

Second Method.—The Calculations under the Form of a Double Columned Table of Ordinates.—Displacement.—Area of Midship Section.—Area of Load-water Line.—Position of the Centre of Gravity of Displacement.—Position of the Centre of Gravity of the Load-water Section.—Relative Capacity of the Two Bodies under the Fore and After Half-length of the Load-water Line.—Height of the Metacentre.—Contrasted Elements of the Vessel obtained under the Two Methods.

THE young Naval Architect has thus been led through the essential calculations on the immersed portion of a ship considered as a floating body. The term essential has here been used under a knowledge, that the table of results might have been swollen to a small volume by a lengthened comparison of the elements of the naval construction, such as the ratio of the area of the midship section to the area of the load-water section, and that of the area of the midship section to the circumscribing parallelogram; data that will always suggest themselves to the mind of an inquiring youth, and furnish him with salutary exercise for his judgment, while the introduction of such comparisons into these rudiments might deter the novice from entering on a task that would thence seem to be involved in such voluminous results. For the second method of calculation, the table of ordinates is in two portions, *viz.*, the fore and after bodies under the division of the load-water section into two equal parts, the length of such section being restricted to the distance from the fore-edge of the rabbet of the stem to the after-edge of the rabbet of the post. The enlarged tables are shown at pages 51 and 52, and the directions for the working of these tables have been given at page 11, observing only that the ordinates have not been herein inserted in red in these tables, as it was there suggested, to insure perspicuity and accuracy.

FORE BODY.—TABLE I.—FIG. 6.

	A		B		C		D		E		F		G		H		I		J		K		L	
	1	2	3	4	5	6	7	8	9	10	11	12	13	14	15	16	17	18	19	20	21	22	23	24
Moments for Centre of Gravity of Displacement.	000-00		20-40		38-30		156-00		56-28		Function of the Solid by Vertical Areas													
Func-tions of the Areas for the Solid.	0-90		20-40		19-15		53-00		14-07		106-52													
Multipliers for Solid.	1		3		1		3		1															
Func-tions of Vertical Areas.	1-80		10-20		19-15		26-00		28-15		Function of the Solid by Longitudinal Areas. 106-50													
	0-10		0-80		1-30		4-00		1-90		7-40		3-70											
	0-50		1-0		2-00		3-2		6-40		8-8		7-60											
	0-12		0-20		2-00		2-20		6-40		1-90		13-03		8-24									
	0-30		1-7		1-70		3-2		4-4		4-40		5-0		5-00									
	0-15		3-40		3-20		8-20		8-80		2-50		18-06		18-06									
	0-70		2-4		4-80		4-2		8-40		5-6		11-20		5-6									
	0-17		4-80		4-20		11-20		2-80		23-17		46-34											
	0-20		3-0		1-50		5-0		2-50		6-0		8-00		6-3									
	0-20		6-00		5-00		13-00		3-15		26-35		18-17											
Summation of the Cubes for the Value of F y 3 dx.	00-083		54-000		120-000		432-000		250-047															
Cubes of the Ordina-tions of Load-water Section.	00-64		27-000		126-000		216-000		250-047															
Moment for Centre of Gravity of Load-water Line.	000-00		6-00		10-00		36-00		12-60															
Functions of Longitudinal Area.	0		1		2		3		4															

AFTER BODY.—TABLE II.

C		A										B		C																											
Moments for Centre of Gravity of Displacement.	4	2		3		4		5		6		7		8		Multipliers for Solid.	Functions of the Areas for the Solid.																								
		1	2	3	4	5	6	7	8	9	10	11	12																												
56.28		2.4	1.20	2.0	1.00	1.4	.70	.6	.30	.2	.10	2.4	1.20	2.0	1.00	1.4	.70	.6	.30	.2	.10	28.15	26.45	20.40	11.25	1.80	14.07	53.90	20.40	22.50	7.20										
264.50		1.20	4.00	1.40	1.20	1.20	1.20	1.20	1.20	1.20	1.20	1.20	1.20	1.20	1.20	1.20	1.20	1.20	1.20	1.20	1.20	1.20	1.20	1.20	1.20	1.20	1.20	1.20	1.20	1.20	1.20										
122.40		3.8	7.60	3.4	6.80	2.4	4.80	1.1	2.20	.25	0.50	5.0	5.00	4.6	4.60	3.4	3.40	1.7	1.70	.3	0.30	5.0	5.00	4.6	4.60	3.4	3.40	2.4	4.80	1.1	2.20	.25	0.50								
157.50		5.6	11.20	5.5	11.00	4.4	8.80	2.6	5.20	.35	.70	5.6	11.20	5.5	11.00	4.4	8.80	2.6	5.20	.35	.70	5.6	11.20	5.5	11.00	4.4	8.80	2.6	5.20	.35	.70	2.2684	25.24	52.08	156.24						
101.906		2.80	11.00	2.50	9.90	3.40	3.40	3.40	3.40	3.40	3.40	2.80	11.00	2.50	9.90	3.40	3.40	3.40	3.40	3.40	3.40	3.40	2.80	11.00	2.50	9.90	3.40	3.40	3.40	3.40	3.40	3.40	3.40	3.40	3.40						
453.963		6.3	3.15	6.1	3.05	5.4	2.70	3.7	1.85	.4	0.20	6.3	3.15	6.1	3.05	5.4	2.70	3.7	1.85	.4	0.20	6.3	3.15	6.1	3.05	5.4	2.70	3.7	1.85	.4	0.20	6.3	3.15	6.1	3.05	5.4	2.70	3.7	1.85	.4	0.20
157.464		8.15	19.20	5.40	11.00	4.40	4.40	5.20	5.20	5.20	5.20	8.15	19.20	5.40	11.00	4.40	4.40	5.20	5.20	5.20	5.20	5.20	8.15	19.20	5.40	11.00	4.40	4.40	5.20	5.20	5.20	5.20	5.20	5.20	5.20	5.20	5.20	5.20	5.20	5.20	
00.083		2.4	1.20	2.0	1.00	1.4	.70	.6	.30	.2	.10	2.4	1.20	2.0	1.00	1.4	.70	.6	.30	.2	.10	2.4	1.20	2.0	1.00	1.4	.70	.6	.30	.2	.10	2.4	1.20	2.0	1.00	1.4	.70	.6	.30	.2	.10
924.00		14.7	27.34	14.7	27.34	14.7	27.34	14.7	27.34	14.7	27.34	14.7	27.34	14.7	27.34	14.7	27.34	14.7	27.34	14.7	27.34	14.7	27.34	14.7	27.34	14.7	27.34	14.7	27.34	14.7	27.34	14.7	27.34	14.7	27.34	14.7	27.34	14.7	27.34		
1573.943		14.7	27.34	14.7	27.34	14.7	27.34	14.7	27.34	14.7	27.34	14.7	27.34	14.7	27.34	14.7	27.34	14.7	27.34	14.7	27.34	14.7	27.34	14.7	27.34	14.7	27.34	14.7	27.34	14.7	27.34	14.7	27.34	14.7	27.34	14.7	27.34	14.7	27.34		

878.86 Function of the Solid. } 110.77
 r = .92 feet.
 r = 5.5 feet.

RESULTS FROM THE TABLES.

By modified rule. Area = $\left\{ \frac{A}{2} + 2P + Q \right\} \frac{2r}{3}$

And solid = areas for ordinates summed by rule } = $\left\{ \frac{A'}{2} + 2P' + Q' \right\} + \frac{2r'}{3}$

Functions of the areas marked B = $\left\{ \frac{A}{2} + 2P + Q \right\}$

Function of the solid equal to B, placed in Sterling's Rules = $\frac{1}{3} + 2P' + Q' = E$

Whence displacement = $E \times \frac{2r}{3} \times \frac{2r'}{3}$, in the example $r = .92$
 $= 5.5$.

Therefore $\frac{1}{2}$ displacement = $E \times \frac{2r}{3} \times \frac{2r'}{3} = E \times \frac{1.84}{3} \times \frac{11}{3} =$
 $E \times \frac{20.24}{9}$

VALUE OF E FROM THE TABLES BY VERTICAL SECTIONS.

Table 1. . 106.50 = submultiple of the fore body by vertical sections.

Table 2. . 110.77 = " after body " "

217.27 = sum of the submultiples = E.

$\frac{1}{2}$ displacement = $E \times \frac{20.24}{9} = \frac{217.27 \times 20.24}{9} = 24.14 \times 20.24 =$

$\frac{488.5936}{2} = \frac{1}{2}$ solid of displacement by the summation of the vertical areas given in cubic feet of space.

5)977.1872

7)195.4374

27.92 = Displacement by vertical sections in tons of 35 cubic feet of space.

VALUE OF E FROM THE TABLES BY HORIZONTAL SECTIONS.

Table 1. . 106.50 = submultiple of the Fore Body by horizontal sections.

Table 2. . 110.75 = submultiple of the After Body by horizontal sections.

From whence the same results will be obtained.

AREA OF MIDSHIP SECTION.

From Table 1. . 28·15 = Submultiple of the area of Section 5.

$$1·84 = 2 r$$

$$\begin{array}{r} 11260 \\ 22520 \\ \hline 2815 \end{array}$$

$$3)51·7960$$

$$17·265 = \frac{1}{2} \text{ area of the upper space of the midship section.}$$

$$3·275 = \frac{1}{2} \text{ area of the lower " " below } d d, \text{ Fig. 8.}$$

$$\begin{array}{r} 20·540 \\ \hline 2 \end{array} = \frac{1}{2} \text{ area of midship section.}$$

$$\begin{array}{r} 41·08 \\ \hline \end{array} = \text{area of midship section.}$$

AREA OF THE LOAD-WATER LINE.

From Table 1. . 26·35 = submultiple of the area of the fore body.

From Table 2. . 28·35 = " " after body.

$$\begin{array}{r} 54·70 \\ \hline 11 \end{array} = \text{submultiple for the } \frac{1}{2} \text{ area of the load-water line.}$$

$$3)601·7$$

$$\begin{array}{r} 200·56 \\ \hline 2 \end{array} = \frac{1}{2} \text{ area} = \frac{A}{2} + 2 P + Q \times \frac{2 r'}{3}$$

$$12)401·12 = \text{area of load-water line.}$$

$$5)33·42$$

$$7)6·684$$

$$\begin{array}{r} \cdot 955 \\ \hline \end{array} = \text{tons per inch of immersion at the load-water line.}$$

POSITION OF THE CENTRE OF GRAVITY OF DISPLACEMENT.

By Table 2. . . . 878·86 = Moments from Section 1.

and E. 217·27 = Corresponding Function of the Displacement.

$$217·27)878·86(\cdot 404 \text{ Intervals of } 5·5 \text{ feet, giving } 4·04 \times 5·5 =$$

$$\begin{array}{r} 869·08 \\ \hline 97800 \\ 86908 \end{array}$$

$$\begin{array}{r} 10892 \\ \hline \end{array}$$

same line, and the sum of the functions, 217·25, is equal to 2·1725 hundreds of cubic feet of space; whence, 4·25 feet, or the difference between the functions for the two bodies, being divided by the function 2·1725, or the function for the displacement of the calculated body expressed in terms of hundreds of cubic feet of space, will give the excess for every hundred cubic feet of that displacement.

Function of Displacement in Hundreds of Cubic Ft. of Space.	Excess in Cubic Feet of Space.	
2·1725)	4·25000	(1·9 ratio of the excess of the after body of calculation over the fore body of the same, denoted by a per-centage of the displacement calculated by the Table of Ordinates.
	2·1725	
	207750	
	195525	
	·12225	

HEIGHT OF THE METACENTRE ABOVE THE CENTRE OF GRAVITY OF DISPLACEMENT.

From Table 2.—The summation of the functions of the cubes of the ordinates for the value of the $\int y^3 dx$ } = 1573·843

The corresponding function for the solid . . . = 217·25

from whence the height of the metacentre above the centre of gravity of displacement, expressed by $\frac{2}{3} \int \frac{y^3 dx}{D}$ is as follow :

$$\int y^3 dx = 1573·843 \times \frac{2r'}{3} \text{ where } r' = 5·5 \text{ feet} =$$

$$\frac{1573·843 \times 11}{3} = \frac{17312·273}{3} = 5770·75 \text{ feet.}$$

(Page 52) $217·27 \times \frac{2r'}{3} \times \frac{2r'}{3} = \frac{1}{2} \text{ displacement} = 488·5936 \text{ feet,}$

whence displacement or D = 977·1872;

and thence

$$\frac{2}{3} \int \frac{y^3 dx}{D} = \frac{2}{3} \times \frac{5770·75}{977·1872} = \frac{11541·53}{2931·5616} = 3·98 \text{ feet.}$$

RESULTS OBTAINED UNDER THE TWO METHODS OF CALCULATION CONTRASTED.

	Old Method.	2nd Method.
Displacement in cubic feet of space	979·139	977·187
Displacement in tons of 35 cubic feet of Water to a ton	27·985	27·92
	Superficial ft.	Superficial ft.
Area of Midship Section	41·08	41·08
Area of Load-water Line or Plane at the proposed deepest immersion	401·12	401·12
Tons to one inch of Immersion at Line of Floatation	·9526 tons.	·955 tons.
Longitudinal Distance of the Centre of Gravity of the Displacement from Section 1, Fig. 8.	22·22 ft.	22·22 ft.
Depth of the Centre of Gravity of Displacement below the Load-water Section	1·4812 ft.	1·4904 ft.
Relative Capacities of the Bodies	1·6 per cent.	1·9 per cent.
Height of the Metacentre above the Centre of Gravity of Displacement	3·98 ft.	3·98 ft.

PART XIII.

Method of forming a Curve of Sectional Areas from a Drawing of Ship.—Calculations for the Displacement from it.—Application of the Method to the Yacht of 36 Tons Admeasurement.—Relative Capacity of the Fore and After Bodies of the Yacht pointed out by the Curve.—Area of Midship Section of the same.—Curve of Sectional Areas used to obtain the Centre of Gravity of Displacement.—Application of it to the Yacht of 36 Tons Admeasurement.

THIRD METHOD OF CALCULATION.

CALCULATIONS ON THE DRAUGHT OF THE YACHT OF 36 TONS USING THE CURVE OF SECTIONAL AREAS.

THE load-water line, A B, in the sheer plan, Fig. 9, is divided into two equal parts at the point C, and those equal parts are again subdivided at the points D and E; at the

points C, D, and E, thus obtained, the transverse vertical sections of the vessel are delineated as shown by Fig. 9.

The length of the load-water line from the fore edge of the rabbet of the stem B, Fig. 9, to the after edge of the rabbet of the post A, is next drawn below and parallel to the base line ST, Fig. 9, of the sheer plan, this line, FG, becomes the base line of the curve of the sectional areas. The common sections of the transverse vertical sections of C, D, and E, (which will be straight lines,) with this horizontal and longitudinal plan, are drawn from their respective points of division, H, I, and K, in half-breadth plan, Fig. 9. The areas of these transverse vertical sections at D, C, and E, are then calculated by Sterling's Rules of

$$\text{Area} = \left\{ A + 4P + 2Q \right\} \times \frac{r}{3} = \left\{ \frac{A}{2} + 2P + Q \right\} \times \frac{2r}{3};$$

$$\text{or, Area} = \left\{ A + 2P + 3Q \right\} \times \frac{3}{8} r = \left\{ \frac{A}{2} + P + 1.5Q \right\} \times \frac{3}{4} r.$$

Half Area of Transverse Vertical Section, at C, by Rule 1,

$$\text{or, } \frac{1}{2} \text{ Area} = \left\{ \frac{A}{2} + 2P + Q \right\} \times \frac{2r}{3}$$

1st. .. 6.3	2nd .. 6.0	3rd .. 4.8 = Q
Last .. .2	4th .. 2.3	

2)6.5	8.3 = P
3.25 = $\frac{A}{2}$	2

$$16.60 = 2P$$

$$3.25 = \frac{A}{2}$$

$$4.80 = Q$$

$$24.65 = \left\{ \frac{A}{2} + 2P + Q \right\} 1$$

$$.83 = \frac{2r}{3}$$

$$7395$$

$$19720$$

$$20.4595 = \left\{ \frac{A}{2} + 2P + Q \right\} \times \frac{2r}{3} =$$

$\frac{1}{2}$ Area of Section C in feet.

C M, or depth = 5.0 feet, whence $\frac{CM}{4}$ or, $\frac{5.0}{4} = 1.25 = r =$
 distance between the ordinates, and $\frac{2r}{3} = \frac{2 \times 1.25}{3} = \frac{2.5}{3} =$
 .83 feet.

Half Area of Section C, by Rule 2.

$$\text{or, } \frac{1}{2} \text{ area} = \left\{ \frac{A}{2} + P + 1.5 Q \right\} \times \frac{3}{4} r.$$

1st. ..	6.3		5.6	2nd.
Last ..	.2	P = 00	3.05	3rd.
	<hr/>		<hr/>	
	2)6.5		8.65 = Q	
	<hr/>		4.32 = $\frac{1}{2}Q$	
	3.25 = $\frac{A}{2}$		<hr/>	
	<hr/>		12.97 = 1.5 Q	

$$\left. \begin{array}{l} 3.25 \\ 12.97 \end{array} \right\} = \frac{A}{2} + P + 1.5 Q$$

$$\frac{16.22}{5} = 3r = CM = 5.0 \text{ ft.}$$

$$\frac{4)81.10}{20.275} = \frac{1}{2} \text{ area} = \left\{ \frac{A}{2} + P + 1.5 Q \right\} \times \frac{3}{4} r.$$

Half Area of the Transverse Vertical Section at E.

1st. ..	5.0	2nd. ..	4.2	3rd. ..	2.9 = Q
Last ..	.2	4th. ..	1.7		
	<hr/>		<hr/>		
	2)5.2		5.9 = P		
	<hr/>		2		
	2.6 = $\frac{A}{2}$		<hr/>		
	<hr/>		11.8 = 2P		
			2.6 = $\frac{A}{2}$		
			2.9 = Q		
			<hr/>		
			17.3 = $\frac{A}{2} + 2P + Q.$		

EO, or depth = 4.2 feet, whence $\frac{EO}{4} = \frac{4.2}{4} = 1.05 = r =$
 distance between the ordinates, and $\frac{2r}{3} = \frac{1.05 \times 2}{3} = \frac{2.1}{3} =$
 .7 feet; therefore,

Area = $\left\{ \frac{A}{2} + 2P + Q \right\} \times \frac{2r}{3} = 17.3 \times .7 = 12.11 =$ half area of transverse vertical section at E.

Half Area of the Transverse Vertical Section at D.

1st. .. 5.40	2nd. .. 3.5	3rd .. 1.46 = Q
Last. .. 0.2	4th. .. 0.7	
2)5.6	4.2 = P	
2.8 = $\frac{A}{2}$	2	
	8.4 = 2P.	
	2.8 = $\frac{A}{2}$	
	1.46 = Q	
	12.66 = $\frac{A}{2} + 2P + Q$	

DN or depth = 5.8 feet whence $\frac{DN}{4} = \frac{5.8}{4} = 1.45$ feet =

r = distance between the ordinates, and $\frac{2r}{3} = \frac{2 \times 1.45}{3} = \frac{2.9}{3} = .97$ feet; therefore,

Area = $\left\{ \frac{A}{2} + 2P + Q \right\} \times \frac{2r}{3} = 12.66 \times .97 = 12.28$ feet = half area of transverse vertical section at D.

Half Areas of the Transverse Vertical Sections.

At $\left\{ \begin{array}{l} \text{E} = 12.11 \\ \text{C} = 20.20 \\ \text{D} = 12.28 \end{array} \right\}$	Divided by 5 as the depth assumed for the zone, give the ordinates for the curve of sectional areas, as	$\left\{ \begin{array}{l} 2.42 \\ 4.04 \\ 2.45 \end{array} \right.$
---	---	---

of which 2.42 is set off from H as HR, 4.04 ft. from I as IQ, and 2.45 ft. from K as KP; the curve IRQPG passing through the extremities P, Q, and R of the ordinates PK, QI and RH is the curve bounding the area of a zone, which to the depth of 5 ft. for a solid, will give in cubic feet of space the half displacement of the immersed body, or the displacement of the yacht to the line AB of proposed deepest immersion.

To measure this representative area, and from thence the solid, join the points Q, G, and I by the straight lines QG, QF, dividing the curvilinear area FRQP GF into the two triangles QGI, QFI, and the two areas GPQG, FRQF. The triangles by construction are equal, and the area of each one of them is equivalent to $\frac{GI \times QI}{2}$, or the whole area

$$GQFIG = \frac{GI \times QI}{2} \times 2 = GI \times QI \text{ or } FI \times IQ,$$

FI being equal to FG, each being the half-length of the same element, the load-water line or line of deepest immersion. The areas QPGQ, QR FQ, are bounded by the curve lines QPG, QRF, which are assumed as portions of common parabolas, and under such an assumption their respective areas are equal to $\frac{2}{3}$ of the circumscribing parallelograms, or the area QPGQ = $\frac{2}{3}$ of GQ \times x, and the area FRQF = $\frac{2}{3}$ of FQ \times x' where x and x' are the greatest perpendiculars that can be drawn from the bases QG and QF to meet the curves QPG, QRF.

FIG. 9. PLATE B.

EXAMPLE.

YACHT OF THIRTY-SIX TONS.

DISPLACEMENT.

EXAMPLE.

AB by a scale of parts = 44 ft., whence FI or $\frac{1}{2}$ FG equal $\frac{AB}{2} = \frac{44}{2}$ ft. = 22 ft.; ordinate QI of the medial section = 4.04 ft.; and QG = FQ being the respective hypotenuses of the equal triangles, QGI, QFI are each equal to $\sqrt{QG^2 + QI^2} = \sqrt{22^2 + 4.04^2} = \sqrt{484 + 16.32} = \sqrt{500.32} = 22.37$ ft. and x by measurement with a scale

of parts = .6 ft. and x' also .6 ft. from which datæ the half displacement in cubic feet of space will be obtained as follows :

Area F Q G I F = G I × I Q.	Cubic feet.
Solid under the } area F Q G I F }	= G I × I Q × 5 = 22 × 4.1 × 5 = 451.00
Area Q P G Q = $\frac{2}{3}$ of G Q × x	
Solid under the } area Q P G Q }	= $\frac{2}{3}$ of G Q × x × 5 = $\frac{2}{3}$ × 22.37 × .6 × 5 = 44.74
Area F R Q F = $\frac{2}{3}$ of F Q × x'	
Solid under the } area F R Q F }	= $\frac{2}{3}$ of F Q × x' × 5 = $\frac{2}{3}$ × 22.37 × .6 × 5 = 44.74
	540.48

or area of the triangle Q G I + area of the triangle Q F I, + area of the space Q P G Q + area of the space F R Q F = to the representative area F R Q P G, which being multiplied by the assumed depth of 5 ft. for the zone of half displacement gives 540.48 cubic feet of space, which divided by 35 as the number of such cubic feet that are equivalent to ton of medium water gives

$$\begin{array}{r} 5)540.48 \\ \hline 7)108.09 \\ \hline \end{array}$$

15.44 tons for half displacement,

and that the whole weight of the body is equal to $15.44 \times 2 = 30.88$ tons = displacement to the line of proposed deepest immersion A B.

RELATIVE CAPACITIES OF THE BODIES IMMERSSED UNDER THE FORE AND AFTER HALF-LENGTHS OF THE LOAD-WATER LINE, AS GIVEN BY THE DELINEATED CURVE OF SECTIONAL AREAS.

The triangles Q G I and Q F I being equal, the relative capacities of the fore and after bodies will be determined by the proportion that the area Q P G I bears to the area Q R F I, and as these areas involve two equal terms, or that

the base $FQ =$ the base QG , it follows, that the relation of these areas to each other will be expressed by the proportion that the perpendiculars x and x' bear to each other. In the example given, the fore and after bodies or the displacements under the fore and after half-lengths of the load-water AB are equal; as the perpendiculars x and x' taken from the diagram, Fig. 9, on a scale of equal parts, are each $\cdot 6$ of a foot.

The area of the midship section is denoted relatively by the medial ordinate of the curve of sections QI , and the full amount of it is obtained by multiplying the function QI by the depth of the zone M . In the example :

$$M = 5; \quad QI = 4\cdot04 : \text{ then half area of medial section} = \frac{4\cdot04 \times 5}{5}$$

$$\text{Area of midship section} \quad . \quad . \quad \underline{\underline{20\cdot20}}$$

CENTRE OF GRAVITY OF DISPLACEMENT BY THE CURVE OF SECTIONAL AREAS.

An approximation to the common centre of gravity of the representative area of the zone, for the solid of displacement under the division of it into four portions, as shown in Fig. 9, may be obtained as follows :

The centre of gravity of the two triangles, from their being equal, will be in the medial section QI , and the common centre of gravity of the four portions of division will thence depend on the relative capacities of the parabolic portions of the representative area, and the positions of their respective centres of gravity.

The position of the centre of gravity of each of the parabolic portions of the representative area may be approximated to, by dividing the hypotenuse into two equal parts and drawing a line from the point of subdivision perpendicular to that line and meeting the curve of sectional areas; the centre

of gravity of the respective portions may be then taken along this line at $\frac{2}{3}$ of it from the curve, and its corresponding solid of displacement may be considered in position at that centre, under which considerations the common centre of gravity of these parabolic portions may be found by equating the moments of them from the centre of gravity of either of them, thus in Fig. 10, under the division of the curve of sectional areas before given, if

FIG. 10.

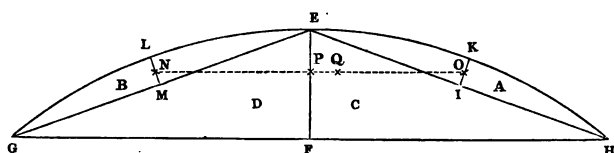

A = fore parabolic portion of the representative area for the half solid of displacement.

B = after ditto; C, the fore-triangular portion of the same area, and D = the after-triangular portion of it, and the hypotenuses EH and GE be bisected in the points I and M, and perpendiculars IK and ML be drawn from these points to meet the curve of sections GEH in the points K and L, then $\frac{2}{3}$ of FK equivalent to KO, and $\frac{2}{3}$ of LM equivalent to LN, will be the approximate distances of the centres of gravity of the parabolic portions of the representative areas from the curve GEH, taken along the lines KI and LM. Join ON and putting x for the distance of the common centre of gravity of the two parabolic portions, A and B from N, and considering the volumes A and B to be in position at their respective centres of gravity, the equation of moments will be as follows :

$$x \times \{A + B\} = A \times ON$$

from which equation, if the value of ON, the distance, that the centres of gravity of the parabolic portions A and B are

apart, be measured by a scale of parts, and A and B be taken in value, the cubic feet of space due to those portions, and these known quantities be substituted in the equation of moments, for their several corresponding terms, the value of x may be determined. Let $x = \overline{NQ}$, whence \overline{PQ} , which is equal to $\overline{NQ} - \overline{NP}$, is known, for which substitute a , then $\{A + B\} \times a = \text{moment of } \overline{A + B} \text{ from medial section,}$ and the common centre of gravity of the portions D and C is in the medial section, from which the common centre of gravity of A, B, D, and C, or of the half displacement from the medial section EF, may be found by the equation of moments.

$$\overline{A + B} \times a + \overline{D + C} \times 0 = \{A + B + D + C\} \times x$$

$$\text{or } A + B \times a = \{A + B + D + C\} \times x$$

$$\text{Whence } x = \frac{\{A + B\} \times a}{A + B + D + C} = \frac{\{A + B\} \times a}{\frac{1}{2} \text{ Displacement,}}$$

and the value of x thus obtained being set off on the straight line GH from the point F, will give the position of the centre of gravity of displacement.

In the example given for the construction drawing of a yacht of 36 tons.

From Fig. 10.

$$\begin{array}{l} A = 44.74 \text{ feet.} \\ B = 44.74 \text{ feet.} \\ C = 225.50 \text{ feet.} \\ D = 225.50 \text{ feet.} \end{array} \left. \vphantom{\begin{array}{l} A \\ B \\ C \\ D \end{array}} \right\} \text{whence } A + B = 89.48.$$

$$\text{And } A + B + C + D = \frac{540.48}{\text{feet, equal to the half displacement.}}$$

$$LM = .6, \text{ whence } LN = \frac{2}{3} \text{ of } LM = \frac{2}{3} \text{ of } .6 = .4, \text{ and}$$

$$KI = .6, \text{ whence } KO = \frac{2}{3} \text{ of } KI = \frac{2}{3} \text{ of } .6 = .4,$$

and the points N and O are the positions of the centres of gravity of the curvilinear spaces GLE G, EKHE, whence NO may be measured by a scale of equal parts, and from

thence PQ be determined. For by the equation of moments, $x \times \overline{A + B} = A \times NO$, where NO by measurement = 16 feet, and $x = NQ$, the point Q being assumed.

$NQ \times \overline{A + B} = A \times NO$ from which by substitution

$$NQ \times 89.48 = 44.74 \times 16, \text{ or } NQ = \frac{715.84}{89.48} = 8 \text{ feet,}$$

which 8 feet being set off from N along the line NO gives the position of the point Q , from whence, by measurement, PQ may be found equal to .75 feet = a of the formula, in which x , or distance of the centre of gravity of displacement

from the medial section = $\frac{\overline{A + B} \times a}{A + B + C + D} = \frac{\overline{A + B} \times a}{\frac{1}{2} \text{ displacement}}$,

or, by substitution, $x = \frac{89.48 \times .75}{540.48} = .12$ feet, the distance

the centre of gravity of displacement is before the medial section EF .

PART XIV.

General Terms of the Curve of Sectional Areas when applied to Naval Construction.—Practical Operations under that System to the Yacht of 36 Tons Admeasurement. — The Method applied to the Construction of a Frigate whose Displacement is 2,300 Tons.

THE CURVE OF SECTIONAL AREAS APPLIED TO NAVAL CONSTRUCTION.

A CONSIDERATION of the armament and its weight, of the number of men necessary to work and fight the ship, with the weight of the provisions and stores for the particular service on which it is intended to employ her, and the weight of her hull or fabric, when completed, will fix the amount of displacement to be given to a naval construction.

The arrangement of that displacement, under the dimen-

sion of the length, breadth, and draught of water, that have been determined on by the constructor, constitutes the theory of Naval Architecture; and the proposed method will be found to facilitate, in no inconsiderable degree, the construction of men-of-war and steam-vessels, and will form a register, by which, from observation and practical results, the best form to be given to them may eventually be determined.

The displacement of the ship, under the considerations before stated, having been decided on,—and the relative capacities, under the fore and after half-lengths of the load-water line, having been fixed, with reference to the stowage and internal arrangements of the ship,—the area of the vertical section, (“at the middle of the load-water line,”) is next to be determined; for which the following equation will hold good by the variation of the decimal part of it to the views of the constructor, or the peculiar service required of the ship; as, under a given displacement, this element, the “area of the immersed midship section,” will regulate the degree of fulness of the bow and quarters of the ship:—

Length on the load-water line, from the fore-part of the rabbet of the stem, to the after-part of the rabbet of the post multiplied by area of midship section multiplied by decimal fraction = displacement. As an example: the decimal fraction of .7 has been found to give the area of midship section, well adapted for frigates. Or, the equation to stand thus:—

$$\text{Area of midship section} = \frac{\text{Displacement in cubic feet}}{\text{Length of load-water line} \times .7}$$

The area of the midship section having been determined, for the convenience of placing a curve of vertical sectional areas on paper, take a submultiple of that area, by dividing the half-area of the midship section by a quantity that will give a quotient less than the half-breadth of the ship, and call this the “middle ordinate of the curve of sectional areas;” or, of a curve, which will, under the length of the load-water line, bound an area, that, to the depth assumed, will form a solid equivalent to

the half-solid of displacement. Next set-off the length of the load-water line, under the points before given; divide the length into two equal parts; and set up, at the middle thus obtained, the "middle ordinate of the curve of sections;" complete the triangles, by joining the extremes of the load-water line and the extremes of the "middle ordinate of the curve of sections;" and find the areas of these triangles, which are similar and equal by construction. The respective differences between the intended half-displacements, in cubic feet under the fore and after half-lengths of the load-water line, and the areas of these triangles will give the required areas to be developed under the curves on the hypotenuse of each triangle, which shall, with the areas of the triangles, make up a submultiple of the half-displacement; and the ordinates of these curves, measured perpendicularly from the base line, or line representing the length of the load-water line, will be submultiples of the area of each transverse section of the immersed body.

THE PROPOSED METHOD OF CONSTRUCTION, STATED IN GENERAL TERMS.

Let the displacement = D ; and take the difference of the respective capacities of the bodies, or the excess of the fore body over the after body, under the fore and after half-lengths of the load-water line, as 4 per cent. of the whole displacement. Let $A B C$, Fig. 11, equal the length on the load-water line; $B D$ = the "middle ordinate of the curve of sections;" join A and D , D and C , thus completing the triangles $A B D$ and $D B C$, which, by construction, are similar and equal. To determine the lines $E F$ and $G H$, the abscissa of each curve required, the following equations must be eliminated. The half-displacement, represented as an area of a zone to a common depth assumed, is to be bounded by a curve $A H D F C$ and the base $A B C$, the length of the load-water line; and the part $D B C F$, under the fore half-length $B C$ of $A B C$, is in excess of the part $D B A H$, under the after half-length $A B$ of

the load-water line A B C, by 4 per cent. on the half-displacement. Or,

$$\text{The area D B C F} \dots = \frac{D}{4} + \frac{4D}{400} = \frac{D}{4} + \frac{D}{100} = \frac{26D}{100}.$$

$$\text{The area D B A H} \dots = \frac{D}{4} - \frac{4D}{400} = \frac{D}{4} - \frac{D}{100} = \frac{24D}{100}.$$

The area D E C F . . . = $\frac{2}{3}$ E F \times D C } if considered to approximate
 The area D G A H . . . = $\frac{2}{3}$ G H \times A D } to a common parabola.

By construction, area D E C F - area D G A H = $\frac{4D}{200} = \frac{2D}{100}$ } As the
 of displacement is to exceed the after body by 4 per cent. on the whole
 displacement.

Also, by construction, area D E C F + area D G A H = $\frac{D}{2}$ - twice area
 of the triangle C B D, or A B D.

$$\text{Or, } \frac{2}{3} \text{ E F} \times \text{D C} - \frac{2}{3} \text{ G H} \times \text{A D} = \frac{4D}{200} = \frac{2D}{100} \quad (1).$$

$$\frac{2}{3} \text{ E F} \times \text{D C} + \frac{2}{3} \text{ G H} \times \text{A D} = \frac{D}{2} \quad (2 \text{ area of triangle CBD}) \quad (2).$$

Or, by adding 1 and 2 together, $\frac{4}{3} \text{ E F} \times \text{D C} = \frac{2D}{100} + \frac{D}{2}$ - (2 area
 of the triangle CBD).

In which equation E F is the only unknown quantity, and the value of it can thence be easily determined; and, when found, if substituted in equation, 1 or 2, the value of G H, will be known. The dimensions for the abscissa of the curves being thus fixed, the respective positions of them along the hypothenuse of the triangles C B D or A B D, will remain to be determined by the views of the constructor, as on the position chosen depends the character of the bow and quarter of the ship. D E = $\frac{2}{3}$ of D C, and D G = $\frac{2}{3}$ of D A have been found to give a curve of sections A D C, which is best adapted for a man-of-war, under the present stowage and internal arrangements. The curve of sectional areas is then made to A H D F C, pass through the points A, H, D, F, and C, forming the representative area of the zone for the half-displacement.

The constructor has next to delineate, according to his ideas, the load-water line, and the form of the midship section, en-

closing the area proposed to be immersed ; and having done which, the load-water line will form the boundary of the final ordinates of the respective areas of each transverse section of the immersed body ; and the areas given by the curve of sections will develop the form of them ; and the bodies (fore and after) will thence be balanced, and the required displacement ensured.

CURVE OF SECTIONAL AREAS AND ZONE OF DISPLACEMENT APPLIED TO THE CONSTRUCTION OF THE YACHT OF 36 TONS ADMEASUREMENT.

The whole displacement was taken at 30·88 tons of medium water of '35 cubic feet to the ton.

Giving the whole displacement as 1080·96 cubic feet of space,

and the half " as 540·48 " "

Length on the water-line assumed to be 44 feet.

Breadth 12·6 feet.

The area of midship section taking as being equal to

$$\frac{\text{Displacement}}{\text{Length of Load-water Line} \times \cdot 6} = \frac{\text{Cubic Feet. Superficial Feet.}}{44 \times \cdot 6} = 40\cdot 9$$

The capacities of the Fore and After Bodies were made equal ;

Or, Fore Body = 540·88 cubic feet of space.

After Body = 540·88 " "

Whence 270·44 = half fore body in cubic feet of space.

270·44 = half after body " "

20·45 = half area of midship section.

6·3 = half breadth.

Dividing the half area of the midship section by 5, as the depth of the zone, gives 4·09 feet for the " middle ordinate of the curve of sections," and 5 becomes the multiple for the representative areas or the depth of the zone.

The length of the load-water line divided by 2 = $\frac{44}{2}$ ft. = 22 ft. = FI or

FG. (Fig. 9, Plate B.) The representative area QIG or QIF = $\frac{IG \times IQ}{2}$
 = $\frac{22 \times 4\cdot 09}{2} = 11 \times 4\cdot 09 = 44\cdot 99$ feet.

The zone or solid under Q I G = Q I G × 5 = 44·99 × 5 =	Cubic Ft. 224·95
The half fore body equals	270·44
Difference	45·49

being equal to the solid under the parabolic area Q P G Q.

$$\begin{aligned} \text{The length of the hypotenuse Q G by calculation} &= \sqrt{22^2 + 4\cdot09^2} \\ &= \sqrt{484 + 16\cdot72} = \sqrt{500\cdot72} = 22\cdot37 \text{ feet.} \end{aligned}$$

To find the value of the abscissa x of the parabolic area Q P G Q, substituting the foregoing values in the equation.

$$\begin{aligned} \text{(P. 69.) } \frac{4}{3} \text{ of Q G} \times x \times \text{depth of zone} &= \frac{D}{2} + \frac{2D}{100} - 2 \left\{ \text{area Q I G} \right. \\ \times \text{depth of the zone, or } \frac{4}{3} x \times 22\cdot37 \times 5 &= \frac{D}{2} - 2, \text{ area of Q I G} \times 5 \\ \text{as } \frac{2D}{100} \text{ is equal to nothing, there being no difference between the bodies;} \end{aligned}$$

$$\text{whence } \frac{4}{3} x \times 22\cdot37 \times 5 = 540\cdot48 - 449\cdot90$$

$$447\cdot4 \times x = 3 \times 90\cdot58$$

$$= 271\cdot74$$

$$\text{and } x = \frac{271\cdot74}{447\cdot4} = \cdot6.$$

The value of x' is the same; the portions of the displacement under the fore and after lengths of the load-water line, or line of deepest immersion, having been assumed equal; the positions of x and x' along the hypotenuses Q G and Q F have in this example been taken at $\frac{1}{3}$ of each respectively, or of Q G and Q F from Q, the curve traced through the points Q, and the extremes of x and x' , (p. 61,) will be the boundary of an area representative of the surface of the half solid of displacement, under a zone 5 feet in depth; and the ordinates of that curve, multiplied by 5, will give the areas of the respective vertical and athwartship immersed sections at each position, thus:—

P K measures, by a scale of parts, 2·45 feet; which, multiplied by 5, gives 12·25 feet as the area of the immersed section O of the sheer plan; and the curve descriptive of the form of the body at the station having been delineated,

the length of the load-water line divided by 2 = 86 ft. = A B or B C.

the representative area ABD or CBD = $\frac{BC \times BD}{2} = \frac{86 \times 11.1}{2}$ or 477.3 ft.

which multiplied by 30 gives 14,319 ft. for the displacement of the triangular portion of the zone.

And the displacement of half-fore body . . .	= 20,930 cubic ft.
Area of triangle D B C	= 14,319 " "
Difference equal to the representative area	<u> </u> " "
bounded by the curve D E C F . . .	<u> </u> = 6,611 cubic ft.

The length of the hypotenuse D C, by calculation = 87.8 ft.

To find E F, substitute these values in the equation :

$$\frac{4}{3} E F \times D C = \frac{D}{2} + \frac{2 D}{100} - 2 (\text{area of triangle A B D or C B D}),$$

$$\frac{4}{3} E F \times 87.8 \times 30 = \left(\frac{D}{2} + \frac{2 D}{100} \right) - 2 (\text{area of triangle A B D}),$$

$$4 E F \times 87.8 \times 10 = 40,250 + 1,610 - 28,638.$$

$$E F \times 3,512 = 12,889$$

$$\text{Or } E F = 3.76 \text{ feet.}$$

And to find the value of G H, we have $\frac{2}{3}$ of E F \times D C - $\frac{2}{3}$ G H \times A D = $\frac{2 D}{100}$

$$= \frac{2}{3} 3.76 \times 87.8 \times 30 - \frac{2}{3} G H \times 87.8 \times 30 = 1,610$$

$$2 3.76 \times 87.8 \times 10 - 2 G H \times 87.8 \times 10 = 1,610$$

$$6602.56 - 1,610 = 1,756 \times G H, \text{ or } G H = \frac{4992.56}{1756} = 2.84 \text{ ft.}$$

Or G H = 2.84 ft. nearly. Also, D E $\frac{2}{3}$ of D C = $\frac{2}{3}$ of 87.8 = 58.7 ft. for the position of the abscissa, F E, from D on the line D C.

A consideration of this groundwork of a simple and certain method of construction, will carry conviction of its utility and great capability. The demonstration of it is not strictly true, in the mathematical sense of that word; but it is founded on that rock; and when the method is practised, it will never deceive, and will very materially lighten the labours of the naval constructor.

FIG. 11.

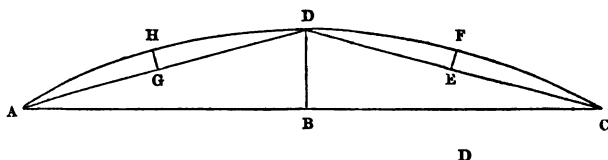

PART XV.

Preliminary Remarks.—Methods of Calculation for the Areas of the Sails.
 —Method of finding the Centres of Gravity of Sails, and determining the Position of the Centre of Effort of the Moving Force or the Sails of a Ship.

HAVING made the principal calculations on the immersed portion of a ship or her displacement, the quantity of sail and its distribution, or the moving force required with relation to the form of the vessel, is the next subject that demands the attention of the Naval Architect. To pass through the mazes that envelop the theory of resistances with which this part of the science, the area of sails, is connected, will not be attempted in this rudimentary work, as such attempts would be highly speculative, not within the assumed attainments of the novice, and would, moreover, yield results of but little practical utility, and thence would be unworthy of the time which must be bestowed on their development.

A plan of the sails having been delineated by the draughtsman, the areas, centres of gravity, and centre of effort, or the centre of pressure of them are found in the following manner.

AREA OF THE SAILS THAT ARE IN FORM TRAPEZOIDS.

A B C D is a trapezoid, the side A B being parallel to C D, and is of the form of the top-sails, courses, and what is termed the square-sails of a ship. This figure is divided into two triangles by the diagonal A D, and to find the areas of these triangles, the perpendiculars,

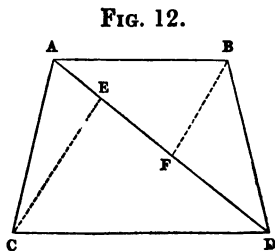

C E and B F to A D, are drawn from the apex of the respective triangles A C D and A B D, under which construction the

$$\text{Area of the triangle A C D} = \frac{A D \times C E}{2},$$

$$\text{Area of the triangle A B D} = \frac{A D \times B F}{2},$$

and the Area of the whole figure A B C D =

$$\frac{A D + C E}{2} + \frac{A D \times B F}{2} = A D \times \frac{C E + B F}{2}.$$

AREA OF THE SAILS THAT ARE TRIANGLES.

In jibs, fore-topmast stay-sails, and all sails triangular in form, the areas are found by multiplying the base into the perpendicular to that base, drawn from the apex of the triangle, the product being divided by 2, or area =

$$\frac{\text{base} \times \text{perpendicular from the apex to the base.}}{2}$$

AREA OF THE SAILS THAT ARE TRAPEZIUMS OR QUADRILATERALS THAT HAVE NOT THEIR OPPOSITE SIDES PARALLEL.

A B C D is a trapezium, and is the form of the driver or boom-mainsail of a ship and that of the mainsail of a cutter, and fore and aft sails of schooners. A B C D is divided by the diagonal A C into the two triangles, A B C and A D C; B F and D E are drawn perpendicular to A C from the points B and D of these triangles, from which construction the area

FIG. 13.

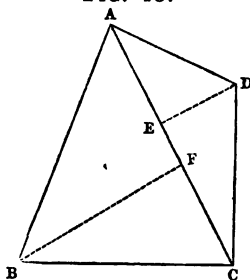

$$A B C = \frac{A C \times B F}{2} \text{ and area A D C} = \frac{A C \times D E}{2} \text{ and the}$$

$$\text{whole area } A B C D = \frac{A C \times B F}{2} + \frac{A C \times D E}{2} =$$

$$A C \times \left\{ \frac{B F + D E}{2} \right\}$$

The sum of the areas of the sails, which in form are comprehended by the three examples given, will be obtained by the summation, under the methods laid down, of all the areas delineated in the plan of the sails.

TO FIND THE CENTRES OF GRAVITY OF THE SAILS.

When of a triangular form, as the jib and fore-topmast stay-sail, &c.

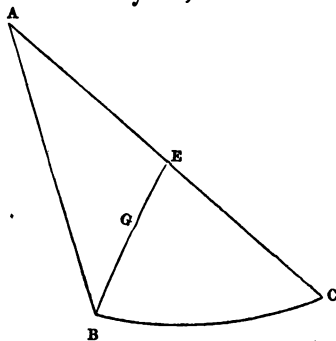

FIG. 14.

Let $A B C$ be a representation of the required sail, then bisect $A C$ in E , join B and E , when $\frac{2}{3}$ of $B E = B G =$ distance of the centre of gravity of the triangle $A B C$ from B , which call G , or centre of gravity of the sail.

When of the form of a trapezoid, as the top-sails, courses, and top-gallant-sails, &c.

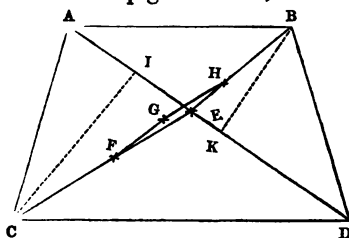

FIG. 15.

Let $A B C D$ represent a top-sail of the form of a trape-

zoid, A B being parallel to C D ; join A and D, dividing the trapezoid into the triangles A C D and A B D ; bisect A D in the point E, and join C and E, B and E ; then the centre of gravity of the triangle A C D will be at the point F which is $\frac{2}{3}$ of C E set-off from C, and the centre of gravity of the triangle A B D will be at the point H which is $\frac{2}{3}$ of B E from B, and the area of the triangle A C B as before shown is equal to $\frac{A D \times C I}{2}$ and the area of the triangle A B D = $\frac{A D \times B K}{2}$ where C I and B K are perpendiculars from the points B and C of the triangles on the base A D, and the whole area A B C D =

$$\frac{A D \times B K}{2} + \frac{A D \times C I}{2} = A D \times \left\{ \frac{B K + C I}{2} \right\} \text{ whence}$$

we have the moments from H, as, area of A B C D \times G H
 = area of A C D \times F H, or A D \times $\left\{ \frac{B K + C I}{2} \right\} \times$ G H
 = $\frac{A D \times C I}{2} \times$ F H,

or if G H = x , $x =$ F H \times $\frac{A D \times C I}{2} \times \frac{2}{A D \times \{B K + C I\}} =$
 $\frac{F H \times C I}{B K + C I} =$ distance of the centre of gravity of the area
 A B C D from the point H, the centre of gravity of the
 triangle A B D, being given in position. The same formula
 will apply to the sails that are trapeziums.

CENTRE OF EFFORT OF THE SAILS.

The areas of the sails and the positions of their centres of gravity having been individually determined by one of the foregoing rules, the centre of effort of them is usually found by assuming, but not necessarily so, an initial plane at the fore extreme of the load-water line, from this plane (which will be represented by a line on the drawing) the distances, by a scale of parts, are taken to the respective centres of gravity of the several sails shown on the drawing, which distances when multiplied into the respective areas of those sails, give the moment of each

sail from the assumed plane : and the sum of these moments being divided by the sum of the areas of the respective sails, or the total area of sail, will give the distance of the common centre of gravity of the sails from it. This is supposing that the centres of gravity of the respective sails are all situated on the one side of the assumed plane ; should the contrary be the case, and that some of them are on the reverse side of the plane, then the difference between the moments of those which fall on either side, divided as before by the whole area of sails, will give the distance the common centre of gravity of them is from the initial plane. This gives the position of the centre of effort of sail with respect to the length of the load-water section. To find its height from that plane, the load-water section, take from the drawing of the sails, by a scale of parts, the height of the centre of gravity of each sail from the load-water line ; this distance for each sail, multiplied by the area of the same, will give its moment of height from that plane ; and the sum of such moments for all the sails, being divided by the whole area of sails, will give the height of the centre of gravity of them from the load-water line. The position of the centre of effort of the sails will thus be fixed ; for the centres of gravity of the same systems of areas having been ascertained for length and height, it follows, that the point in the which they meet is the common centre of gravity of that system, and thence the centre of effort of the sails which it represents.

APPLICATION OF THE RULES FOR CALCULATING THE
AREA OF THE SAILS AND THE POSITION OF THE CENTRE
OF EFFORT OF THE SAILS, TO A YACHT OF 36 TONS.

In Fig. 16, Plate E, or a Delineation of the Sails,

A B C is the Jib.

D E F is the Fore-sail,

G I K H is the Main-sail.

H G H is the Gaff Top-sail.

L M O N is the Mizzen.

These sails having been severally divided for calculation as directed by the Rules.

A' B' the representative plane from which the moments for the position of the centre of effort lengthways are reckoned.

AREA OF SAILS.

$$\begin{aligned} \text{Jib} &= \frac{50.8 \times 17.4}{2} = 25.4 \times 17.4 = 441.96 = \frac{\text{AC} \times \text{BP}}{2} \\ \text{Fore-sail} &= \frac{36 \times 15.4}{2} = 18 \times 15.4 = 197.20 = \frac{\text{EDF} \times \text{EG}}{2} \\ \text{Main-sail} &= 50.4 \times \frac{25 + 12.4}{2} = 25.2 \times 37.4 = 942.48 = \text{GK} \times \frac{(\text{IS} + \text{HT})}{2} \\ \left. \begin{array}{l} \text{Gaff} \\ \text{Top-sail} \end{array} \right\} &= \frac{43.0 \times 19.8}{2} = 21.5 \times 19.8 = 425.70 = \frac{\text{hI} \times \text{GZ}}{2} \\ \text{Mizen} &= 30.4 \times \frac{20 + 9.6}{2} = 15.2 \times 29.6 = 449.92 = \frac{\text{LO} \times \text{Mc} + \text{Na}}{2} \\ & \qquad \qquad \qquad \underline{\qquad \qquad \qquad} \quad \underline{\qquad \qquad \qquad} \\ & \qquad \qquad \qquad \qquad \qquad \qquad \qquad \underline{\qquad \qquad \qquad} \text{Area of Sails in} \\ & \qquad \qquad \qquad \qquad \qquad \qquad \qquad \qquad \qquad \qquad \qquad \qquad \underline{\qquad \qquad \qquad} \text{Superficial Feet.} \end{aligned}$$

POSITIONS OF THE CENTRES OF GRAVITY OF THE SAILS.

Jib = $\frac{2}{3}$ of BP from B = $\frac{2}{3}$ of 17.4 feet = 11.6 feet from B = *g*.

Fore-sail = $\frac{2}{3}$ of EQ = $\frac{2}{3}$ of 18 = 12 feet from E = *r*.

Main-sail, Triangle GIK = $\frac{2}{3}$ of IR = $\frac{2}{3}$ of 28.2 = 18.8 feet from I = *W*.

Main-sail, Triangle GHK = $\frac{2}{3}$ of HR = $\frac{2}{3}$ of 13 = $\frac{2}{3}$ of 13 = 8.8 feet from H = *V*.

Common Centre of Gravity of Main-sail or GIKH } = $\frac{\text{WV} \times \text{IS}}{\text{IS} + \text{HT}} = \frac{13.8 \times 25.0}{25.0 + 12.4} = \frac{34.5}{37.4} = 9.2 \text{ ft.}$ { from V = *u*.

Gaff Top-sail = $\frac{2}{3}$ of GZ = $\frac{2}{3}$ of 19.8 feet = 13.2 feet from G = *x*.

Mizen } Triangle LMO = $\frac{2}{3}$ of Mb = $\frac{2}{3}$ of 21 = 14 ft. from M.
or LMON } Triangle LNO = $\frac{2}{3}$ of Nb = $\frac{2}{3}$ of 10 = 6.6 ft. from N.

Common centre of gravity of mizen or LMON } = $\frac{n o \times \text{Mc}}{\text{Mc} + \text{Nd}} = \frac{10.4 \times 20}{20 + 9.6} = \frac{208.0}{29.6} = 7.0 \text{ ft.}$ { from O = *p*.

n o, by measurement, = 10.4 feet.

CENTRE OF EFFORT FROM A' B'.

Sail.	Areas.	Positions of the Centres of Gravity.	Distances from A' B',*	Moments.
Jib ..	441·96	<i>y</i>	= 2·2 =	972·312 to be subtracted,
Fore-sail..	197·20	<i>r</i>	= 12·0 =	2366·400 add
Main-sail .	942·48	<i>u</i>	= 32·0 =	30159·360 add
Gaff top-sail }	425·70	<i>x</i>	= 26·0 =	11068·200 add
Mizen ..	449·92	<i>p</i>	= 60·0 =	26995·200 add
Area = 2457·26				70589·160
				972·312
				2457·26) 69616·848 (28·33 ft. from A' B'
				491452
				2047164
				1965808
				813568
				737178
				763900
				737178
				26722

= Moments of sails from A' B'

CENTRE OF EFFORT FROM LOAD-WATER LINE.

Sail.	Area.	Positions of the Centres of Gravity.	Distances from Load-water Line.*	Moments.
Jib ..	441·96	<i>y</i>	= 18·0 ..	7955·28
Fore-sail ..	197·20	<i>r</i>	= 16·0 ..	3155·20
Main-sail ..	942·48	<i>u</i>	= 25·0 ..	23562·00
Gaff top-sail	425·70	<i>x</i>	= 52·8 ..	22476·96
Mizen ..	449·92	<i>p</i>	= 15·0 ..	6748·80
Area = 2457·26				2457·26) 63898·24 (25·9 ft.
				491452
				1475304
				1238630
				2366740
				2211534
				155206

* These distances are measured by a scale of parts, from the plans of the sails being square distances of the centres of gravity from the initial plane A' B'.

From which results the position of the centre of effort of the sails may be determined, there being two co-ordinates to fix the place, the one measured from $A'B'$ parallel to the load-water line, and equal to 28·3 feet; the other on a perpendicular to the load-water line, and equal to 25·9 feet; and the point where these intersect, marked thus, \odot , on the plan, denotes the position of the centre of effort.

PART XVI.

SCALE OF CAPACITY FOR THE YACHT OF THIRTY-SIX TONS ADMEASUREMENT.

ON the Sheer Plan, Fig. 8, Plate A., according to the directions given at p. 22, AB being the load-water line or the line of deepest immersion, bb and dd are drawn parallel to AB , and these lines denote the immersions to which the displacements are calculated to form the proposed scale of capacity.

The curve of sectional areas for the immersion AB has been described, Fig. 9, Plate B, and from thence the zone for the displacement has been calculated (p. 62), and found to be equal to 30·88 tons.

DISPLACEMENT TO THE IMMERSION (bb), BY CURVE OF SECTIONAL AREAS, AND ZONE FORMED BY IT.

To obtain the equal spaces of division required for the use of Sterling's Rules, take a scale of parts, and keeping one of the divisions of it well to the base line of the area to be measured, move the scale to meet the extreme ordinate of the area at any equal number of divisions of the scale, then the intermediate equal divisions will give points through which, if lines be drawn parallel to the base line, the area will be divided into an even number of spaces, and the ordinates will be an odd number for the use of the first rule given by Sterling.

Half Area of the Vertical Section 2, Fig. 8, Plate A,
when immersed to the depth of $b b$, or 2·1 ft.

1st . . 2·25	2nd . . 1·35	3rd . . 0·00 = Q
5th . . ·20	4th . . 0·00	
2)2·45	1·35 = P	
1·22 = $\frac{A}{2}$	2·70 = 2 P	
	1·22 = $\frac{A}{2}$	
	0·00 = Q	
	3·92 = $\frac{A}{2} + 2 P + Q$	

the depth being equal to 2·1 ft., and the number of equal divisions being taken as two, giving 3 as the number of ordinates, the spaces between the ordinates will be equal to

$$\frac{2·1}{2} = r \text{ of the formula whence } \frac{2r}{3} = \frac{\frac{2·1}{2} \times 2}{3}, \text{ or } \frac{2r}{3} \text{ will equal}$$

$$\frac{\text{whole depth}}{3} = \frac{2·1}{3} = \cdot 7 \text{ feet.}$$

With five ordinates, under the same rule, $\frac{2r}{3}$ will equal

$$\frac{\text{whole depth}}{6}, \text{ with seven ordinates } \frac{2r}{3} = \frac{\text{whole depth}}{9}.$$

$$3·92 = \frac{A}{2} + 2 P + Q$$

$$\cdot 7 = \frac{2r}{3}$$

$$\frac{2·744}{3} = \frac{A}{2} + 2 P + Q \times \frac{2r}{3} = \frac{1}{3} \text{ Area of Vertical Section 2.}$$

Half Area of the Vertical Section 3, when immersed to the depth of $b b$, or 2.4 feet.

$$\begin{array}{r}
 3.7 \\
 .2 \\
 \hline
 2)3.9 \\
 \hline
 1.95 = \frac{A}{2}
 \end{array}
 \qquad
 \begin{array}{r}
 3.0 \\
 1.15 \\
 \hline
 4.15 = P \\
 2 \\
 \hline
 8.30 = 2P \\
 1.95 = \frac{A}{2} \\
 2.15 = Q \\
 \hline
 12.40 = \frac{A}{2} + 2P + Q \\
 .4 = \frac{2r}{3} \\
 \hline
 4.96 = \frac{A}{2} + 2P + Q \times \frac{2r}{3} = \frac{1}{2} \text{ Area of the Vertical Section 3.}
 \end{array}
 \qquad
 \begin{array}{r}
 2.15 = Q \\
 6)2.4 = \text{depth at 3.} \\
 \hline
 .4 = \frac{2r}{3}
 \end{array}$$

Half Area of the Vertical Section 4, when immersed to the depth of $b b$, or 2.75 feet.

$$\begin{array}{r}
 5.0 \\
 .25 \\
 \hline
 2)5.25 \\
 \hline
 2.62 = \frac{A}{2}
 \end{array}
 \qquad
 \begin{array}{r}
 4.0 \\
 1.5 \\
 \hline
 5.5 = P \\
 2 \\
 \hline
 11.00 = 2P \\
 2.62 = \frac{A}{2} \\
 2.80 = Q \\
 \hline
 16.42 = \frac{A}{2} + 2P + Q \\
 .46 = \frac{2r}{3} \\
 \hline
 9852 \\
 6568 \\
 \hline
 7.5532 = \frac{A}{2} + 2P + Q \times \frac{2r}{3} = \left\{ \frac{1}{2} \text{ Area of Vertical Section 4.} \right.
 \end{array}
 \qquad
 \begin{array}{r}
 2.8 = Q \\
 6)2.75 = \text{depth at 4.} \\
 \hline
 .46 = \frac{2r}{3}
 \end{array}$$

Half Area of the Vertical Section 5, when immersed to the depth of bb , or 3.1 feet.

$$\begin{array}{r}
 5.4 \\
 \cdot 25 \\
 \hline
 2)5.65 \\
 \hline
 2.82 = \frac{A}{2}
 \end{array}
 \qquad
 \begin{array}{r}
 4.5 \\
 1.55 \\
 \hline
 6.05 = P \\
 2 \\
 \hline
 12.10 = 2P \\
 2.82 = \frac{A}{2} \\
 3.10 = Q \\
 \hline
 18.02 = \frac{A}{2} + 2P + Q \\
 .516 = \frac{2r}{3} \\
 \hline
 10812 \\
 1802 \\
 9010 \\
 \hline
 9.29832 = \frac{A}{2} + 2P + Q \times \frac{2r}{3} = \left\{ \frac{1}{2} \text{ Area of Vertical Section 5.} \right.
 \end{array}
 \qquad
 \begin{array}{r}
 3.1 = Q \\
 6)3.10 = \text{depth at 5.} \\
 \hline
 .516 = \frac{2r}{3}
 \end{array}$$

Half Area of the Vertical Section 6, when immersed to the depth of bb , or 3.5 feet.

$$\begin{array}{r}
 4.3 \\
 \cdot 2 \\
 \hline
 2)4.5 \\
 \hline
 2.25 = \frac{A}{2}
 \end{array}
 \qquad
 \begin{array}{r}
 3.6 \\
 1.1 \\
 \hline
 4.7 = P \\
 2 \\
 \hline
 9.4 = 2P \\
 2.25 = \frac{A}{2} \\
 2.10 = Q \\
 \hline
 13.75 = \frac{A}{2} + 2P + Q \\
 .58 = \frac{2r}{3} \\
 \hline
 11000 \\
 6875 \\
 \hline
 7.9750 = \frac{A}{2} + 2P + Q \times \frac{2r}{3} = \left\{ \frac{1}{2} \text{ Area of Vertical Section 6.} \right.
 \end{array}
 \qquad
 \begin{array}{r}
 2.1 = Q \\
 6)3.5 = \text{depth at 6.} \\
 \hline
 .58 = \frac{2r}{3}
 \end{array}$$

Half Area of the Vertical Section 8, when immersed to the depth of $b\ b$, or 4.2 feet.

$$\begin{array}{r}
 2) \begin{array}{r} 2.05 \\ .20 \\ \hline 2.25 \\ \hline 1.12 = \frac{A}{2} \end{array} \\
 \end{array}
 \qquad
 \begin{array}{r}
 1.05 \\
 .35 \\
 \hline 1.40 = P \\
 2 \\
 \hline 2.80 = 2P \\
 1.12 = \frac{A}{2} \\
 .60 = Q \\
 \hline 4.52 = \frac{A}{2} + 2P + Q \\
 .7 = \frac{2r}{3} \\
 \hline 3.164 = \frac{A}{2} + 2P + Q \times \frac{2r}{3} = \left\{ \frac{1}{2} \text{ Area of Vertical Section 8.} \right.
 \end{array}
 \qquad
 \begin{array}{r}
 .60 = Q \\
 6) 4.2 = \text{depth at 8.} \\
 \hline .7 = \frac{2r}{3}
 \end{array}$$

Formation of the curve G D L, by these areas, or the delineation of the curve G D L of the curves of sectional areas, Plate C, as the representative area of the zone of displacement to the immersion $b\ b$, the depth of the zone being taken as three feet. The points L and G in the base A B, which form the endings of the curve G D L, are obtained from Fig. 8, Plate A, by squaring down the intersections of the line $b\ b$, with the fore-edge of the rabbet of the stem, and after-edge of the rabbet of the stern-post, the line A B being the length of the load-water line; under similar limits, therefore, L G equals the length of the water $b\ b$, of Fig. 8, Plate A.

Distinguishing Number of the Vertical Sections.	Half Areas of the Vertical Sections. Feet.	Divisor.	Ordinates for the Curve of Sections.
2 . .	2.744 . .	3 . .	.914
3 . .	4.916	1.638
4 . .	7.553	2.517
5 . .	9.298	3.10 = F D
6 . .	7.975	2.658
8 . .	3.164	1.054

Results obtained from the Curve of Sectional Areas formed on the base L G.

Length of the water line $bb = 42.8$ ft. whence $FL = FG = \frac{bb}{2} = 21.4$ ft.

$$\text{Area of the Fore Triangle } FDL = \frac{FL \times FD}{2} = \frac{21.4 \times 3.1}{2}.$$

Zone under the Area $DFL = \frac{FL \times FD}{2} \times 3 = \frac{21.4 \times 3.1}{2} \times 3 = 99.51$ cubic feet of space.

$$\text{Area of the After Triangle } FDG = \frac{FD \times FG}{2} = \frac{3.1 \times 21.5}{2}.$$

Zone under the Area $DFG = \frac{FD \times FG}{2} \times 3 = \frac{3.1 \times 21.5}{2} \times 3 = 99.96$ cubic feet of space.

$$\text{Fore Hypotenuse } DL = \sqrt{LF^2 + DF^2} = \sqrt{21.4^2 + 3.1^2} = \sqrt{467.57} = 21.62 \text{ feet.}$$

Fore Parabolic Area contained under the hypotenuse DL and the curve $= DL \times \frac{2}{3}$ of the maximum perpendicular on $DL = 21.62 \times \frac{2}{3}$ of $.3$.

Zone under that area $= 21.62 \times \frac{2}{3}$ of $.3 \times 3 = 12.972$ cubic feet of space.

$$\text{After Hypotenuse } DG = \sqrt{FG^2 + DF^2} = \sqrt{21.5^2 + 3.1^2} = \sqrt{471.86} = 21.72 \text{ feet.}$$

After Parabolic Area contained under the Hypotenuse DG and the curve is equal to $DG \times \frac{2}{3}$ of the maximum perpendicular on $DG = 21.72 \times \frac{2}{3}$ of $.5$.

Zone under that Area $= 21.72 \times \frac{2}{3}$ of $.5 \times 3 = 21.72$ cubic feet of space.

Whence, for the Half Displacement to the Immersion bb .

	Cubic Feet.
Fore Zone under the Fore Triangle FDL	= 99.51
After Zone " " After " " FDG	= 99.96
Fore Zone under the Parabolic Area .	= 12.97
After Zone " " " " .	= 21.72
	5)234.16 cubic ft.
	7)46.83
	6.69 =

Half Displacement in tons of 35 cubic feet of space, and $6.69 \times 2 = 13.38$ tons = Displacement under the immersion bb .

**DISPLACEMENT TO THE ASSUMED IMMERSION dd ,
FIG. 8, PLATE A.**

**Half Area of the Vertical Section 3 to the depth of dd ,
or .65, considered to be a Triangle.**

Base or Breadth of the Horizontal Section dd at 3, as shown	feet.
on the Half-breadth Plan, Fig. 8, Plate A	= 1.15
Depth at 3, taken from the Sheer Plan, Fig. 8, Plate A	= .65
	575
	690

Product of these two . = 7.475

Which, divided by 2, gives 3.73 feet for the Half Area of the Vertical Section 3, under the immersion dd .

**Vertical Section 4.
Considered as a Triangle, then the**

Base as similarly taken for (3)	feet.
Depth " "	= 2.0
	= 1.0

Product of these quantities = 2.0

Which, divided by 2, gives 1.0 foot for the Half Area of the Vertical Section 4, under the immersion dd .

**Half Area of the Vertical Section 5, when immersed to the
depth dd , or 1.35 feet.**

2.65	2.15	1.5 = Q	6)1.35 = depth at 5.
.20	1.00		.22 = $\frac{2r}{3}$
2)2.85	3.15 = P		

$$\frac{1.42}{1} = \frac{A}{2}$$

$$\begin{aligned} & \frac{3.15}{2} = P \\ & 6.30 = 2P \\ & 1.42 = \frac{A}{2} \\ & 1.50 = Q \\ & 9.22 = \frac{A}{2} + 2P + Q \\ & .22 = \frac{2r}{3} \end{aligned}$$

$$\frac{1844}{1844} = \frac{A}{2} + 2P + Q \times \frac{2r}{3} = \left\{ \begin{array}{l} \frac{1}{2} \text{ Area of Vertical} \\ \text{Section 5, under the} \\ \text{immersion } dd. \end{array} \right.$$

Half Area of the Vertical Section 6, when immersed to the depth $d d$, or 1.7 feet.

$$\begin{array}{r}
 2.05 \\
 \cdot 20 \\
 \hline
 2)2.25 \\
 \hline
 1.12 = \frac{A}{2}
 \end{array}
 \qquad
 \begin{array}{r}
 1.55 \\
 \cdot 60 \\
 \hline
 2.15 = P \\
 \hline
 2 \\
 \hline
 4.30 = 2P \\
 1.12 = \frac{A}{2} \\
 1.00 = Q \\
 \hline
 6.42 = \frac{A}{2} + 2P + Q \\
 \cdot 283 = \frac{2r}{3} \\
 \hline
 1926 \\
 5136 \\
 1284 \\
 \hline
 1.81686 = \frac{A}{2} + 2P + Q \times \frac{2r}{3} = \left\{ \begin{array}{l} \frac{1}{2} \text{ Area of Vertical} \\ \text{Section 6, under the} \\ \text{immersion } d d. \end{array} \right.
 \end{array}
 \qquad
 \begin{array}{r}
 1.00 = Q \\
 6)1.7 = \text{depth at 6.} \\
 \hline
 \cdot 283 = \frac{2r}{3}
 \end{array}$$

Half Area of the Vertical Section 8, when immersed to the depth $d d$, or 2.4 feet.

$$\begin{array}{r}
 \cdot 75 \\
 \cdot 20 \\
 \hline
 2) \cdot 95 \\
 \hline
 \cdot 475 = \frac{A}{2}
 \end{array}
 \qquad
 \begin{array}{r}
 \cdot 55 \\
 \cdot 30 \\
 \hline
 \cdot 85 = P \\
 \hline
 2 \\
 \hline
 1.70 = 2P \\
 \cdot 475 = \frac{A}{2} \\
 \cdot 400 = Q \\
 \hline
 2.575 = \frac{A}{2} + 2P + Q \\
 \cdot 4 = \frac{2r}{3} \\
 \hline
 1.0300 = \frac{A}{2} + 2P + Q \times \frac{2r}{3} = \left\{ \begin{array}{l} \frac{1}{2} \text{ Area of Vertical} \\ \text{Section 8, under the} \\ \text{immersion } d d. \end{array} \right.
 \end{array}
 \qquad
 \begin{array}{r}
 \cdot 4 = Q \\
 6)2.4 = \text{depth at 8.} \\
 \hline
 \cdot 4 = \frac{2r}{3}
 \end{array}$$

Distinguishing Number of the Vertical Sections.	Half Areas of the Vertical Sections. Feet.	Divisor.	Ordinates for the Curve of Sections.
3	.7475	1	.74
4	1.0000	.	1.0
5	2.0280	.	2.02 = F E
6	1.8168	.	1.80
8	1.0300	.	1.03

Results from the Curve of Sectional Areas formed by these Ordinates, considered as circumscribing an Area representative of the Half Displacement under the immersion *dd* of Fig. 8, Plate A.

Plate C.

Length of the load-water line at the immersion *dd* = 39.35 F K = 18.5 and H F = 20.85 feet.

$$\text{Area of the Fore Triangle F E K} = \frac{F K \times F E}{2} = \frac{18.5 \times 2.02}{2}$$

$$\text{Solid, or Zone, under such Area} = \frac{K F \times F E}{2} \times 1 = \frac{18.5 \times 2.02}{2} \times 1 = 18.685 \text{ cubic feet.}$$

$$\text{Area of the After Triangle H F E} = \frac{H F \times F E}{2} = \frac{20.85 \times 2.02}{2}$$

$$\text{Solid, or Zone, under such Area} = \frac{H F \times F E}{2} \times 1 = \frac{20.85 \times 2.02}{2} \times 1 = 21.058 \text{ cubic feet.}$$

$$\text{After Hypothenuse H E} = \sqrt{H F^2 + F E^2} = \sqrt{20.85^2 + 2.02^2} = \sqrt{438.8} = 20.95.$$

After Parabolic Area = E H $\times \frac{2}{3}$ of the maximum perpendicular on E H = 20.95 $\times \frac{2}{3}$ of .6.

After Zone, or Solid, under that Area = 20.95 $\times \frac{2}{3}$ of .6 $\times 1$ = 8.380 cubic feet,

By measurement with a scale of equal parts, the Hypothenuse for the Fore Parabolic Area equals 15.8 feet.

Whence Fore Parabolic Area = 15.8 $\times \frac{2}{3}$ of .5; where .5 is the maximum perpendicular on the hypothenuse.

Fore Zone, or Solid, under that Area = 15.8 $\times \frac{2}{3}$ of .5 $\times 1$ = 5.26 cubic feet.

The division of the curve of sectional areas into four portions, viz., two triangles and two parabolic areas, points out, in

this case, that the fore triangular area exceeds the area required by the fore parabolic area, and that thence the solid will be under a similar excess ; in summing these portions for the amount of half displacement, the solid under the fore parabolic area must be subtracted from the sum of the three other portions, or the half displacement under the immersion, $d d$ will be obtained from the foregoing calculations by adding together the following :

	Cubit Feet of Space.
Zone, or Solid, under Fore Triangle . . . =	18·685
" " " After " . . . =	21·058
" " " under After Parabolic Area . . =	8·380
	48·123
And subtracting	
Zone, or Solid, under the Fore Parabolic Area . =	5·260
	42·863 =
Half Displacement in cubic feet of space to the immersion $d d$; whence	
$42·863 \times 2 = 85·726 =$ whole Displacement in cubic feet of space due to the immersion $d d$.	

which, divided by 35, or $5)85·726$

$$\begin{array}{r} \underline{7)17·145} \\ \hline \end{array}$$

2·45 gives 2·45 tons Displacement
to the immersion $d d$.

Under these results, to form a scale for tonnage, proceed as described in page 23, by assuming CD on the scale of tons, Plate C, as a line of scale for depth or mean draught of water, the lower part of which, D , is at the same depth as the underside of the false keel of the vessel amidships, and delineate on this line, CD , a scale of parts ; on this scale set off the midships depths of the calculated immersions, or those at 55 section, Fig. 8, Plate A ; draw lines at the points thus obtained perpendicular to this scale of depth, as FG , HI , KL , MN , and draw EA parallel to CD , the lower point E being considered as at the depth of the underside of the false keel, and thence on a level with the point D of the scale of parts ; from the point A in EA (assumed as convenient) draw a line AB parallel to FG , and on it form a scale of equal parts for tons,

as shown in the scale for tonnage, Plate C, to be numbered to 32 tons : in this Fig., FE corresponds to the immersion AB at 55, or amidships, HE, to the immersion of *bb* at 55, or amidships, KE, to the immersion of *dd* at 55 or amidships, and ME to the immersion of the keel : the calculated displacements due to these respective immersions are as follow :—

To the immersion for A B, or Load-water Line	. .	30·88 Tons.
" " " <i>bb</i> " 2nd "	. .	13·98 "
" " " <i>dd</i> " 3rd "	. .	2·45 "
" " " of the keel " "	. .	·66 "

These displacements are set off on the scale A B, as shown in the Fig., Plate C.

Where	A R	=	30·88	}	parts of the Scale of Tons ;
	A Q	=	13·98		
	A P	=	2·45		
	A O	=	·66		

and the points R, Q, P, and O, thus determined, are squared down to meet the lines FG, HI, KL, and MN, drawn square to the line CD in the points G, I, L, and M, when a curve, passed through those points, will form a scale of tons for the displacement to any assumed or real immersion considered as the midship immersion ; thus, should the displaced volume or tonnage be required at a mean immersion of 5 feet, a line must be drawn from 5 on the scale for the mean draught of water amidship, Plate C, parallel to FG, to meet the curve ENLIG in some point S, which point S being squared up to the scale for tons, will cut the scale in the point V, as denoting 19·8 tons, which will be the volume due to that immersion ; the same for any other point of required immersion, and thence, conversely, may be determined the increased draught of water the vessel would draw on additional weights being placed in her. The yacht being at a mean draught of water amidships of 4·3 feet, it is required the additional immersion that will ensue from her taking on board six tons of ballast ; at 4·3 feet immersion, the scale, Plate C, gives A Q on the

line denoting the tonnage, or 13·98 tons ; to which, if the six tons required to be placed on board be added, the sum will be 19·98 tons, which will give the point V, on the scale for tons, which point squared down gives the point S in the curve E N L I G ; and that point being transferred to the scale C D, gives 5 feet as the immersion which the increased weight placed on board will cause, or that six tons would at the mean draught of water of 4·3 feet, immerse the vessel bodily ·7 feet, or $8\frac{1}{2}$ inches nearly. A similar process will give the weight required to be taken out of the vessel, to bring her up to any given or assumed draught of water ; as, from 5 feet to 4·3 feet, which would involve a process the converse of that given for the addition of six tons.

PART XVII.

An Example of the Comparison of the Forms of Ships, by the Curve of Sections being applied to the Vertical Sections of her Majesty's Ship Vanguard, of the Year 1835, and the French Canopus, of the Year 1786 ; and a further Application of the Curve of Sectional Areas to the Light and Load Displacements of the same Men of War ; with a view of showing their relative Capacities for carrying Weights, and to facilitate their Stowage, as pointed out in page 17.

THE Plate D is descriptive of the longitudinal sections of the ships, the athwartship vertical sections being thrown down on them at their respective stations, to show the forms of the ships, the curves or form of them being to the outside of the plank of the bottom. The areas to the water lines for light and load-water displacements are then measured by Rule 1, as follows :—A B being the load-water line, and D C the light-water line, of H. M. S. Vanguard.

VANGUARD.—LOAD DISPLACEMENT.

Midship Section, or Vertical Section 3, Plate D.

27·8 ·8 <hr style="width: 50px; margin: 0;"/> 2)28·6 <hr style="width: 50px; margin: 0;"/>	26·9 23·8 17·6 7·2 <hr style="width: 50px; margin: 0;"/>	25·6 21·2 13·2 <hr style="width: 50px; margin: 0;"/>	12)21·6 = { depth of 3. <hr style="width: 50px; margin: 0;"/>
$14·3 = \frac{A}{2}$	$75·5 = P$ <hr style="width: 50px; margin: 0;"/>	$60·0 = Q$ <hr style="width: 50px; margin: 0;"/>	$1·8 = \frac{2r}{3}$ <hr style="width: 50px; margin: 0;"/>
	$151·0 = 2P$ $14·3 = \frac{A}{2}$ $60·0 = Q$		
	$225·3 = \frac{A}{2} + 2P + Q$ $1·8 = \frac{2r}{3}$ <hr style="width: 50px; margin: 0;"/>		
	18024 2253		
	$405·54 = \frac{A}{2} + 2P + Q \times \frac{2r}{3} = \left\{ \begin{array}{l} \frac{1}{2} \text{ Area of Midship} \\ \text{Section when} \\ \text{immersed to the} \\ \text{load draught of} \\ \text{water, A B.} \end{array} \right.$		

Vanguard. Vertical Section 2, Plate D.

27·2 ·8 <hr style="width: 50px; margin: 0;"/>	27·0 24·2 18·4 8·0 <hr style="width: 50px; margin: 0;"/>	26·0 21·8 14·0 <hr style="width: 50px; margin: 0;"/>	12)21·4 = { depth of 2. <hr style="width: 50px; margin: 0;"/>
2)28·0 <hr style="width: 50px; margin: 0;"/>	$77·6 = P$ <hr style="width: 50px; margin: 0;"/>	$61·8 = Q$ <hr style="width: 50px; margin: 0;"/>	$1·78 = \frac{2r}{3}$ <hr style="width: 50px; margin: 0;"/>
	$155·2 = 2P$ $61·8 = Q$ $14·0 = \frac{A}{2}$		
	$231·0 = \frac{A}{2} + 2P + Q$ $1·78 = \frac{2r}{3}$ <hr style="width: 50px; margin: 0;"/>		
	1848 1617 231		
	$411·18 = \frac{A}{2} + 2P + Q \times \frac{2r}{2} = \left\{ \begin{array}{l} \frac{1}{2} \text{ Area of Vertical} \\ \text{Section 2, when} \\ \text{immersed to the} \\ \text{load draught of} \\ \text{water, A B.} \end{array} \right.$		

Vanguard. Vertical Section 1, Plate D.

25·4	23·8	22·0	12)21·2 = { depth of 1
·8	19·4	16·04	
2)26·2	12·80	9·2	1·76 = $\frac{2r}{3}$
13·1 = $\frac{A}{2}$	5·20	47·24 = Q	
	61·20 = P		
	122·4 = 2 P		
	13·1 = $\frac{A}{2}$		
	47·24 = Q		
	182·74 = $\frac{A}{2} + 2P + Q$		
	1·76 = $\frac{2r}{3}$		
	109644		
	127918		
	18274		
	321·6224 = $\frac{A}{2} + 2P + Q \times \frac{2r}{3}$		{ $\frac{1}{3}$ Area of Vertical Section 1, when im- mersed to the load draught of water, A B.

Vanguard. Vertical Section 4, Plate D.

27·2	26·4	25·2	12)22·0 = { depth of 4.
·80	22·8	19·6	
2)28·00	15·8	11·2	1·83 = $\frac{2r}{3}$
14·00 = $\frac{A}{2}$	6·2	56·0 = Q	
	71·2 = P		
	142·4 = 2 P		
	14·0 = $\frac{A}{2}$		
	56·0 = Q		
	212·4 = $\frac{A}{2} + 2P + Q$		
	1·83 = $\frac{2r}{3}$		
	6372		
	16992		
	2124		
	388·692 = $\frac{A}{2} + 2P + Q \times \frac{2r}{3}$		{ $\frac{1}{3}$ Area of Vertical Section 4, when immersed to the load draught of water, A B.

Vanguard. Vertical Section 5, Plate D.

$$\begin{array}{r}
 24\cdot60 \\
 \underline{-80} \\
 2)25\cdot40 \\
 \underline{\quad} \\
 12\cdot7 = \frac{A}{2}
 \end{array}
 \qquad
 \begin{array}{r}
 23\cdot00 \\
 16\cdot20 \\
 \underline{8\cdot80} \\
 3\cdot00 \\
 \underline{\quad} \\
 51\cdot00 = P \\
 \underline{\quad} \\
 102\cdot00 = 2 P \\
 12\cdot70 = \frac{A}{2} \\
 \underline{38\cdot80 = Q} \\
 \underline{\quad} \\
 153\cdot50 = \frac{A}{2} + 2 P + Q \\
 \underline{1\cdot85 = \frac{2r}{3}} \\
 7675 \\
 12280 \\
 \underline{1535} \\
 283\cdot975 = \frac{A}{2} + 2 P + Q \times \frac{2r}{2} =
 \end{array}
 \qquad
 \begin{array}{r}
 12)22\cdot20 = \left\{ \begin{array}{l} \text{depth} \\ \text{of 5.} \end{array} \right. \\
 \underline{\quad} \\
 1\cdot85 = \frac{2r}{3}
 \end{array}$$

$\frac{1}{2}$ Area of Vertical Section 5, when immersed to the load draught of water, A B.

From these half areas, the curve EGF of sectional areas, forming the representative area for the zone of half displacement, is formed in the following manner: take EF, Plate D, parallel to the lower edge of keel, and equal in length to where the load-water AB of Vanguard cuts the fore edge of the rabbet of the stem and after edge of the rabbet of the post, and to the line AB square down the positions of the vertical sections 1, 2, 3, 4, and 5, of the Sheer Plan, Plate D; then for the representative ordinates of the curve of sections to the load-displacement at those stations, we have the following estimated data:—

Distinguishing Number of the Vertical Sections.	Half Area of Vertical Sections.	Divisor.	Ordinates for Curve. Feet.
1 . .	321·62 . .	30 . .	10·72
2 . .	411·18	13·706
3 . .	405·54	13·518 = H G
4 . .	388·69	12·956
5 . .	283·97	9·465

which ordinates are set off from EF on their respective stations 1.1, 2.2, 3.3, 4.4, and 5.5, giving the points for the curve EGF , and the area EGF bounded by that curve and the line EF . EF by measurement = 186 ft., whence EH and FH are equal to $\frac{186}{2} = 93$ ft., and the whole area EGF when divided into the four portions; the triangle FHG , triangle EHG , parabolic area under the hypotenuse GF , and the parabolic area under the hypotenuse GE , can be thus numerically determined:—

Area of the Triangle FHG = Area of Triangle EHG = $\frac{EH \times HG}{2}$;
whence the sum of the Areas FHE and EHG = $EH \times HG$.

Or, the Areas of the Triangles $FHG + EHG$ = $EH \times HG$ =
93.0 ft. \times 13.518.

And Solid, or Zone, under such Area = $93.0 \times 13.518 \times 30 = 37715.220$
cubic feet of space.

$$\begin{aligned} \text{Hypotenuse } EG \text{ or } FG &= \sqrt{EH^2 + HG^2} = \sqrt{93.0^2 + 13.52^2} = \\ \sqrt{8649.0 + 182.79} &= \sqrt{8831.79} = 93.97 \text{ feet.} \end{aligned}$$

Area $GKFG$ = $\frac{2}{3} FG \times$ maximum perpendicular on FG , (p. 61.) =
 $\frac{2}{3}$ of 93.97×6.0 .

Solid, or Zone, under
the Area $GKFG$ } = $\frac{2}{3}$ of $FG \times$ maximum perpendicular on $FG \times$
 $30 = 2 \times 93.97 \times 6.0 \times 10 = 11276.4$ cubic feet of space.

Area $ELGE$ = $\frac{2}{3}$ of $EG \times$ maximum perpendicular on EG , (p. 61.)
= $\frac{2}{3}$ of 93.97×4.6 .

Solid, or Zone, under
the Area $ELGE$ } = $\frac{2}{3}$ of $EG \times$ maximum perpendicular on $EG \times$
 $30 = 2 \times 93.97 \times 4.6 \times 10 = 8645.24$ cubic feet of space.

From which is obtained the following summary for the displacement to the immersion AB , or load line of the Vanguard.

Solid or Zone under the Areas F H G + E H G in } = 37715.22
 cubic feet of space }
 Solid or Zone under the Fore Parabolic Area G K F G } = 11276.40
 in cubic feet of space }
 Solid or Zone under the After Parabolic Area E L G E } = 8645.24
 in cubic feet of space }

Divided by 35 as the number of cubic feet equal to a Ton. 5)57636.86

7)11527.37

1646.76 Tons.

= $\frac{1}{4}$ Displacement of Vanguard, and $1646.76 \times 2 = 3293.52$ Tons =
 whole Displacement to a draught of Water { Afore . . . 23.0 ft.
 Aft . . . 24.0

Light Displacement of Vanguard by the Curve of Sectional Areas, and Zone for the Solid to the Draught of Water.

Afore . . . = 16.25 feet.
 Aft . . . = 18.5 "

Half Area of Vertical Section 1.

20.8	18.2	15.2	9)14.8 = depth
.8	12.0	8.4	<u> </u> = $\frac{2r}{3}$
<u> </u>	4.6	<u> </u>	1.64 = $\frac{2r}{3}$
2)21.6	<u> </u>	23.6 = Q	
<u> </u>	34.8 = P	<u> </u>	
10.8 = $\frac{A}{2}$	2		
<u> </u>			

69.6 = 2 P
 10.8 = $\frac{A}{2}$
 23.6 = Q

 104.0 = $\frac{A}{2} + 2 P + Q$
 1.64 = $\frac{2r}{3}$

416
 624
 104

 $170.56 = \frac{A}{2} + 2 P + Q \times \frac{2r}{3} =$ { $\frac{1}{4}$ Area of Vertical Section 1, when immersed to the light draught of water D C.

Half Area of Vertical Section 2.

$$\begin{array}{r}
 .25 \cdot 2 \\
 \quad .8 \\
 \hline
 2) 26 \cdot 0 \\
 \hline
 13 \cdot 0 = \frac{A}{2}
 \end{array}$$

$$\begin{array}{r}
 23 \cdot 4 \\
 17 \cdot 6 \\
 \quad 8 \cdot 2 \\
 \hline
 49 \cdot 2 = P \\
 \quad 2 \\
 \hline
 98 \cdot 4 = 2P
 \end{array}$$

$$\begin{array}{r}
 9) 15 \cdot 4 = \text{depth} \\
 \hline
 1 \cdot 7 = \frac{2r}{3}
 \end{array}$$

$$\begin{array}{r}
 13 \cdot 0 = \frac{A}{2} \\
 34 \cdot 2 = Q \\
 \hline
 145 \cdot 6 = \frac{A}{2} + 2P + Q \\
 1 \cdot 7 = \frac{2r}{3}
 \end{array}$$

$$\begin{array}{r}
 10192 \\
 1456 \\
 \hline
 247 \cdot 52 = \frac{A}{2} + 2P + Q \times \frac{2r}{3} = \left\{ \begin{array}{l} \frac{1}{2} \text{ Area of Vertical} \\ \text{Section 2, when immersed to the light} \\ \text{draught of water.} \end{array} \right.
 \end{array}$$

Half Area of Vertical Section 3.

$$\begin{array}{r}
 25 \cdot 8 \\
 \quad .8 \\
 \hline
 2) 26 \cdot 6 \\
 \hline
 13 \cdot 3 = \frac{A}{2}
 \end{array}$$

$$\begin{array}{r}
 23 \cdot 6 \\
 17 \cdot 0 \\
 \quad 7 \cdot 0 \\
 \hline
 47 \cdot 6 = P \\
 \quad 2 \\
 \hline
 95 \cdot 2 = 2P
 \end{array}$$

$$\begin{array}{r}
 9) 16 = \text{depth} \\
 \hline
 1 \cdot 8 = \frac{2r}{3}
 \end{array}$$

$$\begin{array}{r}
 13 \cdot 3 = \frac{A}{2} \\
 32 \cdot 6 = Q \\
 \hline
 141 \cdot 1 = \frac{A}{2} + 2P + Q \\
 1 \cdot 8 = \frac{2r}{3}
 \end{array}$$

$$\begin{array}{r}
 11288 \\
 1411 \\
 \hline
 253 \cdot 98 = \frac{A}{2} + 2P + Q \times \frac{2r}{3} = \left\{ \begin{array}{l} \frac{1}{2} \text{ Area of Vertical} \\ \text{Section 3, when immersed to the light} \\ \text{draught of water.} \end{array} \right.
 \end{array}$$

Half Area of Vertical Section 4.

$\begin{array}{r} 25\cdot2 \\ \cdot8 \\ \hline 2)26\cdot0 \\ \hline 13\cdot0 = \frac{A}{2} \end{array}$	$\begin{array}{r} 23\cdot2 \\ 16\cdot0 \\ \hline 6\cdot2 \\ \hline 45\cdot4 = P \\ \hline 2 \\ \hline 90\cdot8 = 2P \\ 13\cdot0 = \frac{A}{2} \\ 31\cdot4 = Q \\ \hline 135\cdot2 = \frac{A}{2} + 2P + Q \\ 1\cdot82 = \frac{2r}{3} \\ \hline 2704 \\ 10816 \\ 1352 \\ \hline 246\cdot064 = \frac{A}{2} + 2P + Q \times \frac{2r}{3} = \left\{ \begin{array}{l} \frac{1}{2} \text{ Area of Vertical} \\ \text{Section 4, when im-} \\ \text{mersed to the light} \\ \text{draught of water.} \end{array} \right.$	$\begin{array}{r} 20 \\ 11\cdot4 \\ \hline 31\cdot4 = Q \\ \hline 9)16\cdot40 = \left\{ \begin{array}{l} \text{depth of} \\ \text{Section.} \end{array} \right. \\ \hline 1\cdot82 = \frac{2r}{3} \end{array}$
---	---	--

Half Area of Vertical Section 5.

$\begin{array}{r} 20\cdot4 \\ \cdot8 \\ \hline 2)21\cdot2 \\ \hline 10\cdot6 = \frac{A}{2} \end{array}$	$\begin{array}{r} 17\cdot4 \\ 9\cdot8 \\ \hline 3\cdot4 \\ \hline 30\cdot6 = P \\ \hline 2 \\ \hline 61\cdot2 = 2P \\ 10\cdot6 = \frac{A}{2} \\ 19\cdot8 = Q \\ \hline 91\cdot6 = \frac{A}{2} + 2P + Q \\ 1\cdot86 = \frac{2r}{3} \\ \hline 5496 \\ 7328 \\ 916 \\ \hline 170\cdot376 = \frac{A}{2} + 2P + Q \times \frac{2r}{3} = \left\{ \begin{array}{l} \frac{1}{2} \text{ Area of Vertical} \\ \text{Section 5, when im-} \\ \text{mersed to the light} \\ \text{draught of water.} \end{array} \right.$	$\begin{array}{r} 13\cdot6 \\ 6\cdot2 \\ \hline 19\cdot8 = Q \\ \hline 9)16\cdot8 = \text{depth} \\ \hline 1\cdot86 = \frac{2r}{2} \end{array}$
---	---	---

From these half areas, the curve NMO of sectional areas, forming the representative area for the zone of the half-light displacement, is formed in the following manner:—square down the points N and O to the line EF , such points being where the light-water line DC , in the Sheer Plan, Plate D , cuts respectively the after edge of the rabbet of the stern post and fore edge of the rabbet of the stem, the positions of the vertical sections 1, 2, 3, 4, and 5, remaining the same as for the load displacement; then, for the representative ordinates to the curve of sections to the light displacement at those stations, we have the following estimated data.

Distinguishing Number of the Vertical Sections.	Half Areas of the Vertical Sections. Superficial Feet.	Divisor.	Ordinates for the Curve.
1	170·56	30	5·68
2	247·52		8·25
3	253·98		8·46 = Hm
4	246·06		8·20
5	170·37		5·67

which ordinates are set off from the base EF , Plate D , on the respective stations, as $11'$, $22'$, $33'$, $44'$, and $55'$, giving the points for the curve NMO , and the area NMO bounded by that curve and the base NO , part of the base EF . NO , being equal to the length of the light-water section CD , is equal by measurement to $182\cdot8$ feet, of which the fore length $HO = 90\cdot0$ ft., whence $NH = NO - HO = 182\cdot8$ ft. $- 90 = 92\cdot8$ feet; and the area NMO , when divided into the four portions, the triangle HMO , the triangle HMN , the parabolic area under the hypotenuse MO , and the parabolic area under the hypotenuse MN , can be numerically determined as follows:—

$$\text{Area of the Triangle } HMO = \frac{OH \times MH}{2} = \frac{90 \times 8\cdot46}{2} = 380\cdot7.$$

$$\text{Solid or Zone under such Area} = \frac{OH \times MH}{2} \times 30 = \frac{90 \times 8\cdot46}{2} \times 30 = 11421\cdot0.$$

$$\text{Area of the Triangle H M N} = \frac{NH \times HM}{2} = \frac{92.8 \times 8.46}{2} = 392.544.$$

$$\text{Solid or Zone under such Area} = \frac{NH \times HM}{2} \times 30 = \frac{92.8 \times 8.46}{2} \times 30 = 11776.3.$$

$$\begin{aligned} \text{Fore Hypothenuse M O} &= \sqrt{OH^2 + HM^2} = \sqrt{90^2 + 8.46^2} = \\ &= \sqrt{8100 + 71.57} = \sqrt{8171.57} = 90.4 \text{ feet.} \end{aligned}$$

The Fore Parabolic Area M P O M = $\frac{2}{3}$ of M O \times maximum perpendicular on M O. (Page 61.)

$$\begin{aligned} \text{Solid or Zone under } \left. \begin{array}{l} \text{the Area M P O M} \\ \text{the Area M P O M} \end{array} \right\} &= \frac{2}{3} \text{ of M O} \times \text{maximum perpendicular on M O} \times \\ &= \frac{2}{3} \text{ of } 90.4 \times 2.8 \times 30 = 5062.4 \text{ cubic ft.} \end{aligned}$$

$$\begin{aligned} \text{After Hypothenuse M N} &= \sqrt{NH^2 + HM^2} = \sqrt{92.8^2 + 8.46^2} = \\ &= \sqrt{8611.84 + 71.57} = \sqrt{8683.41} = 93.2 \text{ feet.} \end{aligned}$$

The After Parabolic Area N Q M N = $\frac{2}{3}$ of N M \times maximum perpendicular on M N. (Page 61.)

$$\begin{aligned} \text{Solid or Zone under } \left. \begin{array}{l} \text{the Area M Q M N} \\ \text{the Area M Q M N} \end{array} \right\} &= \frac{2}{3} \text{ of M N} \times \text{maximum perpendicular on M N} \times \\ &= \frac{2}{3} \text{ of } 93.2 \text{ ft.} \times 2.6 \times 30 = 4846.4 \text{ cubic ft.} \end{aligned}$$

	Cubic feet of Space.
Solid or Zone under the Fore Triangular } Area H M O }	= 11421.0
Solid or Zone under the After Triangular } Area H M N }	= 11776.3
Solid or Zone under the Fore Parabolic } Area M P O M }	= 5062.4
Solid or Zone under the After Parabolic } Area N Q M N }	= 4846.4
	5)33106.1
	7)6621.22
	945.89 = $\frac{1}{2}$ Light
	2 Displace-
	ment in
	Tons.
Light Displacement in Tons of Medium } Water of 35 Cubic Feet to the Ton . }	= 1891.78

CANOPUS OF 1786.

Load Displacement to a Draught { Afore = 22.0 ft. } Plate D.
 of Water of { Aft. = 24.5 ft. }

Half Area of Vertical Section 3.

26.0	25.6	25.0	12)20.8 = depth
.80	24.0	22.8	<u> </u> = $\frac{2r}{3}$
<u> </u>	20.8	17.6	<u> </u> = $\frac{2r}{3}$
2)26.80	12.6	<u> </u>	
<u> </u>	<u> </u>	65.4 = Q	
13.40 = $\frac{A}{2}$	83.0 = P		
	2		

$$166.0 = 2P$$

$$13.4 = \frac{A}{2}$$

$$65.4 = Q$$

$$244.8 = \frac{A}{2} + 2P + Q$$

$$1.73 = \frac{2r}{3}$$

7344

17136

2448

$$423.504 = \frac{A}{2} + 2P + Q \times \frac{2r}{3} = \left\{ \frac{1}{2} \text{ Area of Vertical Section 3 to the depth of the load-water line.} \right.$$

Half Area of Vertical Section 2.

25.40	25.00	24.20	12)20.6 = depth
.80	23.40	22.20	<u> </u> = $\frac{2r}{3}$
<u> </u>	20.20	17.20	<u> </u> = $\frac{2r}{3}$
2)26.2	12.20	<u> </u>	
<u> </u>	<u> </u>	63.60 = Q	
13.1 = $\frac{A}{2}$	80.80 = P		
	2		

$$161.60 = 2P$$

$$13.1 = \frac{A}{2}$$

$$63.60 = Q$$

$$238.30 = \frac{A}{2} + 2P + Q$$

$$1.71 = \frac{2r}{3}$$

2383

16681

2383

$$407.493 = \frac{A}{2} + 2P + Q \times \frac{2r}{3} = \left\{ \frac{1}{2} \text{ Area of Vertical Section 2 to the depth of the load-water line.} \right.$$

Half Area of Vertical Section 1.

24·0	22·8	21·2	12)20·4 = depth
<u>·8</u>	18·8	16·6	<u>1·7 = $\frac{2r}{3}$</u>
2)24·8	13·4	9·8	
<u>12·4 = $\frac{A}{2}$</u>	5·6	<u>47·6 = Q</u>	
	<u>60·6 = P</u>		

$$121·2 = 2 P$$

$$12·4 = \frac{A}{2}$$

$$47·6 = Q$$

$$181·2 = \frac{A}{2} + 2 P + Q$$

$$1·7 = \frac{2r}{3}$$

<u>12684</u>	}	Area of Vertical Section 1 to the depth of the load-water line.
<u>1812</u>		
<u>308·04 = $\frac{A}{2} + 2 P + Q \times \frac{2r}{3}$</u>		

Half Area of Vertical Section 4.

25·2	25·0	24·2	12)21·0 = depth
<u>·8</u>	22·8	20·8	<u>1·75 = $\frac{2r}{3}$</u>
2)26·0	18·0	14·4	
<u>13·0 = $\frac{A}{2}$</u>	9·4	<u>59·4 = Q</u>	
	<u>75·2 = P</u>		

$$150·4 = 2 P$$

$$13·0 = \frac{A}{2}$$

$$59·4 = Q$$

$$222·8 = \frac{A}{2} + 2 P + Q$$

$$1·75 = \frac{2r}{3}$$

<u>11140</u>	}	Area of Vertical Section 4 to the depth of the load-water line.
<u>15596</u>		
<u>2228</u>		
<u>389·900 = $\frac{A}{2} + 2 P + Q \times \frac{2r}{3}$</u>		

Half Area of Vertical Section 5.

$$\begin{array}{r}
 23\cdot6 \\
 \cdot 8 \\
 \hline
 2)24\cdot4 \\
 \hline
 12\cdot2 = \frac{A}{2}
 \end{array}
 \qquad
 \begin{array}{r}
 22\cdot8 \\
 15\cdot6 \\
 \hline
 8\cdot0 \\
 2\cdot4 \\
 \hline
 48\cdot8 = P \\
 \hline
 2
 \end{array}
 \qquad
 \begin{array}{r}
 20\cdot6 \\
 11\cdot4 \\
 \hline
 5\cdot0 \\
 \hline
 37\cdot0 = Q
 \end{array}
 \qquad
 \begin{array}{r}
 12)21\cdot52 = \text{depth} \\
 \hline
 1\cdot8 = \frac{2r}{3}
 \end{array}$$

$$\begin{array}{r}
 97\cdot6 = 2P \\
 12\cdot2 = \frac{A}{2} \\
 37\cdot0 = Q \\
 \hline
 146\cdot8 = \frac{A}{2} + 2P + Q \\
 1\cdot8 = \frac{2r}{3}
 \end{array}$$

$$\begin{array}{r}
 11744 \\
 1468 \\
 \hline
 264\cdot24 = \frac{A}{2} + 2P + Q \times \frac{2r}{3} = \left\{ \begin{array}{l} \frac{1}{3} \text{ Area of the Vertical} \\ \text{Section 5, when} \\ \text{immersed to the} \\ \text{load-water line.} \end{array} \right.
 \end{array}$$

From the data given by the foregoing Vertical Areas, the curve } ft. in.
of Sectional Areas and Zone for the Load Displacement of } = 22 ,, 0
H.M. Ship Canopus, to the Draught of Water of Afore }
Ditto Aft = 24 ,, 6
may be formed.

Distinguishing Number of the Vertical Sections.	Half Areas of the Vertical Sections. Superficial Feet.	Divisor.	Ordinates for the Curve of Sections.
1	308·00	30	10·26
2	407·49	13·58
3	423·5	14·12 = <i>f c</i>
4	389·9	12·99
5	264·24	8·80

From these ordinates the curve of sectional areas, *a, b, c, d, e*, for the load-displacement can be delineated for the Canopus as directed for the formation of a similar curve for the Vanguard; the extremes of the curve being as before, the limits of the load-water line of the ship squared down to the base *ae*. To measure the representative area, *a, b, c, d, e, f, a*; *f c* being the medial

section; divide it into four portions, the triangles acf and fce , and the parabolic areas contained under the hypotenuses, ac , ce , and the curve. To estimate the numerical values of these areas, we have

Length of load-water line = 193·2 feet ;

whence $af = fe = \frac{193\cdot2}{2}$ feet = 96·6 feet, and fc , is by calculation equal to 14·12 feet.

$$\begin{aligned} \text{Area of fore representative triangle } cfe &= \frac{fe \times fc}{2} = \frac{96\cdot6 \times 14\cdot12}{2} \text{ ft.} \\ &= \frac{1363\cdot992}{2} = 681\cdot996. \end{aligned}$$

$$\begin{aligned} \text{Solid under such area} &= \frac{fe \times fc}{2} \times 30 = \frac{96\cdot6 \times 14\cdot12}{2} \times 30 = \\ \frac{1363\cdot992}{2} \times 30 &= 20459\cdot88 \text{ cubic feet of space.} \end{aligned}$$

$$\begin{aligned} \text{After triangular representative area } acf &= \frac{af \times fc}{2} \text{ solid} = \frac{fe \times fc}{2} \\ \times 30 &= 20459\cdot88 \text{ cubic feet of space.} \end{aligned}$$

$$\begin{aligned} \text{The hypotenuse } ce = ac &= \sqrt{af^2 + fc^2} = \sqrt{96\cdot6^2 + 14\cdot12^2} = \\ \sqrt{9331\cdot56 + 199\cdot37} &= \sqrt{9530\cdot9} = 97\cdot6 \text{ feet.} \end{aligned}$$

Fore parabolic area $cdec = ce \times \frac{2}{3}$ of the maximum perpendicular on ce = 97·6 $\times \frac{2}{3}$ of 5·4.

Zone or solid under such area = $ce \times \frac{2}{3}$ of the maximum perpendicular on $ce \times 30 = 97\cdot6 \times \frac{2}{3}$ of 5·4 $\times 30 = 10540\cdot8$ cubic feet of space.

After parabolic area $abca = ac \times \frac{2}{3}$ of the maximum perpendicular on ac = 97·6 $\times \frac{2}{3}$ of 4·2.

Zone or solid under such area = $ac \times \frac{2}{3}$ of the maximum perpendicular on $ac \times 30 = 97\cdot6 \times \frac{2}{3}$ of 4·2 $\times 30 = 8198\cdot4$.

	ft. in.	
From which the half load displacement of Canopus to	} 22 0	} is as follows.
the draught of water of Afore		
Ditto Aft	} 24 6	

	Cubic Feet.
Solid from the triangles <i>cfe</i> , <i>cfa</i> = 20459·88 × 2	= 40919·76
„ fore parabolic <i>cdec</i> . . .	= 10540·80
„ after „ <i>abca</i> . . .	= 8198·40
	5)59658·96
	7)11931·79
	1704·54
Tons. or 1704·54 = $\frac{1}{2}$ displacement	
3409·08 = load displacement of Canopus to Afore	22 ft. 0 in.
„ „ „	Aft 24 ft. 6 in.

Light Displacement of H. M. Ship Canopus by the Curve of Sectional Areas and Zone for the solid to the Draught of Water.

	ft. in.
Afore . . .	= 14 „ 3
Aft . . .	= 18 „ 9

Half Area of Vertical Section 1.

19·6	17·8	15·4	9)13·6 = de
·8	12·4	9·4	<u>1·51 = $\frac{2r}{3}$</u>
2)20·4	5·8	<u>24·8 = Q</u>	
10·2 = $\frac{A}{2}$	36·0 = P		
	<u>2</u>		
	72·0 = 2 P		
	10·2 = $\frac{A}{2}$		
	24·8 = Q		
	<u>107·0 = $\frac{A}{2} + 2 P + Q$</u>		
	1·51 = $\frac{2r}{3}$		
	<u>107</u>		
	535		
	<u>107</u>		
	<u>161·57 = $\frac{A}{2} + 2 P + Q \times \frac{2r}{3}$</u>		}

$\frac{1}{2}$ Area of the Vertical Section 1, when immersed to the depth of the light-water immersion.

Half Area of Vertical Section 2.

$$\begin{array}{r} 24\cdot0 \\ \cdot 8 \\ \hline 2)24\cdot8 \\ \hline 12\cdot4 = \frac{A}{2} \end{array}$$

$$\begin{array}{r} 23\cdot0 \\ 19\cdot6 \\ 12\cdot0 \\ \hline 54\cdot6 = P \\ \hline 2 \end{array}$$

$$\begin{array}{r} 21\cdot6 \\ 17\cdot0 \\ \hline 38\cdot6 = Q \end{array}$$

$$\begin{array}{r} 9)14\cdot2 = \text{depth} \\ \hline 1\cdot58 = \frac{2r}{3} \end{array}$$

$$\begin{array}{r} 109\cdot2 = 2P \\ 12\cdot4 = \frac{A}{2} \\ 38\cdot6 = Q \\ \hline 160\cdot2 = \frac{A}{2} + 2P + Q \\ 1\cdot58 = \frac{2r}{3} \end{array}$$

$$\begin{array}{r} 12816 \\ 8010 \\ 1602 \\ \hline \end{array}$$

$$\underline{\underline{253\cdot116}} = \frac{A}{2} + 2P + Q \times \frac{2r}{3} =$$

$\left\{ \frac{1}{3} \right.$ Area of the Vertical Section 2, when immersed to the depth of the light-water immersion.

Half Area of Vertical Section 3.

$$\begin{array}{r} 24\cdot4 \\ \cdot 8 \\ \hline 2)25\cdot2 \\ \hline 12\cdot6 = \frac{A}{2} \end{array}$$

$$\begin{array}{r} 24\cdot0 \\ 20\cdot6 \\ 12\cdot6 \\ \hline 57\cdot2 = P \\ \hline 2 \end{array}$$

$$\begin{array}{r} 22\cdot6 \\ 18\cdot4 \\ \hline 41\cdot0 = Q \end{array}$$

$$\begin{array}{r} 9)15\cdot00 = \text{depth} \\ \hline 1\cdot66 = \frac{2r}{3} \end{array}$$

$$\begin{array}{r} 114\cdot4 = 2P \\ 12\cdot6 = \frac{A}{2} \\ 41\cdot0 = Q \\ \hline 168\cdot0 = \frac{A}{2} + 2P + Q \\ 1\cdot66 = \frac{2r}{3} \end{array}$$

$$\begin{array}{r} 1008 \\ 1008 \\ 168 \\ \hline \end{array}$$

$$\underline{\underline{278\cdot88}} = \frac{A}{2} + 2P + Q \times \frac{2r}{3} =$$

$\left\{ \frac{1}{3} \right.$ Area of Vertical Section 3, when immersed to the depth of the light-water immersion.

Half Area of Vertical Section 4.

$$\begin{array}{r}
 24 \cdot 20 \\
 \cdot 8 \\
 \hline
 2) 25 \cdot 0 \\
 \hline
 12 \cdot 5 = \frac{A}{2}
 \end{array}
 \qquad
 \begin{array}{r}
 22 \cdot 8 \\
 18 \cdot 0 \\
 \hline
 9 \cdot 4 \\
 \hline
 50 \cdot 2 = P \\
 \hline
 2
 \end{array}
 \qquad
 \begin{array}{r}
 20 \cdot 8 \\
 14 \cdot 0 \\
 \hline
 34 \cdot 8 = Q
 \end{array}
 \qquad
 \begin{array}{r}
 9) 15 \cdot 8 = \text{depth} \\
 \hline
 1 \cdot 75 = \frac{2r}{3}
 \end{array}$$

$$100 \cdot 4 = 2P$$

$$12 \cdot 5 = \frac{A}{2}$$

$$34 \cdot 8 = Q$$

$$147 \cdot 7 = \frac{A}{2} + 2P + Q$$

$$1 \cdot 75 = \frac{2r}{3}$$

$$7385$$

$$10339$$

$$1477$$

$$258 \cdot 475 = \frac{A}{2} + 2P + Q \times \frac{2r}{3} =$$

$\frac{1}{2}$ Area of Vertical Section 4, when immersed to the depth of the light-water immersion.

Half Area of the Vertical Section 5.

$$\begin{array}{r}
 19 \cdot 6 \\
 \cdot 8 \\
 \hline
 2) 20 \cdot 4 \\
 \hline
 10 \cdot 2 = \frac{A}{2}
 \end{array}
 \qquad
 \begin{array}{r}
 16 \cdot 0 \\
 8 \cdot 2 \\
 \hline
 2 \cdot 4 \\
 \hline
 26 \cdot 6 = P \\
 \hline
 2
 \end{array}
 \qquad
 \begin{array}{r}
 11 \cdot 6 \\
 5 \cdot 0 \\
 \hline
 16 \cdot 6 = Q
 \end{array}
 \qquad
 \begin{array}{r}
 9) 16 \cdot 4 = \text{depth} \\
 \hline
 1 \cdot 82 = \frac{2r}{3}
 \end{array}$$

$$53 \cdot 2 = 2P$$

$$10 \cdot 2 = \frac{A}{2}$$

$$16 \cdot 6 = Q$$

$$80 \cdot 0 = \frac{A}{2} + 2P + Q$$

$$1 \cdot 82 = \frac{2r}{3}$$

$$160$$

$$640$$

$$80$$

$$145 \cdot 60 = \frac{A}{2} + 2P + Q \times \frac{2r}{3} =$$

$\frac{1}{2}$ Area of Vertical Section 5, when immersed to the depth of the light-water immersion.

From these calculations, the following data is given to form a curve of sectional areas for the light displacement of H. M. S. Canopus.

To a Draught of Water of Afore	ft. in.
	= 14 ,, 3
Ditto Aft	= 18 ,, 9

Distinguishing Number of the Vertical Sections.	Half Areas of the Vertical Sections. Superficial Feet.	Distances.	Ordinates for the Curve of Sections.
1 . . .	161·57 . . .	30 . . .	5·38
2 . . .	253·11	8·437
3 . . .	278·88	9·29 = <i>f i</i>
4 . . .	258·47	8·61
5 . . .	145·60	4·85

From these ordinates the curve of sectional areas, *g, h, i, k, m*, for the light displacement can be formed for the Canopus, as shown for the similar curve to the Vanguard; the extremes of the curve *g* and *m* being the limits of the light-water line, or the points where the light-water line cuts the after edge of the rabbet of the post, and the fore edge of the rabbet of the stem, squared down to the base, *a c*. To measure the representative area, *g, h, i, k, m, g*, and thence the zone for the light displacement, join *g* and *i*, and *m* and *i*; which will divide the area, *g, h, i, k, m, g* into two triangles, *f i m* and *f i g*, together with the parabolic areas, *i k m i* and *i h g i*, being the areas contained under the hypotenuses, *i m, g i*, and the curve *g, h, i, k, m*.

To estimate the numerical values of these areas, we have

f m by measurement = 94·0 ft., and *f g* = 96·2 feet, and *f i* by calculation = 9·29 feet.

$$\text{Whence Area of the Fore Representative Triangle } \left. \right\} f i m = \frac{f m \times f i}{2} = \frac{94 \cdot 0 \times 9 \cdot 29}{2} = 436 \cdot 63$$

$$\text{Solid under that Area } \left. \right\} = \frac{f m \times f i}{2} \times 30 = \frac{94 \cdot 0 \times 9 \cdot 29}{2} \times 30 = 13098 \cdot 9$$

$$\text{Area of the After Representative Triangle } \left. \right\} f i g = \frac{f g \times f i}{2} = \frac{96 \cdot 2 \times 9 \cdot 29}{2} = 446 \cdot 849$$

Solid under that Area = $\frac{fg \times fi}{2} \times 30 = \frac{96.2 \times 9.29}{2} \times 30 = 13405.47$ cubic feet of space.

The Hypothenuse $im = \sqrt{fm^2 + fi^2} = \sqrt{94^2 + 9.29^2} = \sqrt{8836 + 86.30} = \sqrt{8922.3} = 94.50$ feet.

Fore Parabolic Area $ikmi = im \times \frac{2}{3}$ of the maximum perpendicular on im .

Zone or Solid under such Area = $im \times \frac{2}{3}$ of the maximum perpendicular on $im \times 30 = im \times \frac{2}{3}$ of $2.2 \times 30 = 94.5 \times 44 = 4158.0$.

The Hypothenuse $gi = \sqrt{fg^2 + fi^2} = \sqrt{96.2^2 + 9.29^2} = \sqrt{9254.44 + 86.30} = \sqrt{9340.74} = 96.6$ feet.

After Parabolic Area $ghig = gi \times \frac{2}{3}$ of the maximum perpendicular on gi .

Zone or Solid under such Area = $gi \times \frac{2}{3}$ of the maximum perpendicular on $gi \times 30 = 96.6 \times \frac{2}{3}$ of 2.0 ft. $\times 30 = 3864.0$ feet.

From which data the half-light Displacement of Canopus is as follows:—

	Cubic feet of space.
Solid from the Triangle fim	= 13098.9
Ditto . . . fig	= 13405.47
Solid under the Fore Parabolic Area $ikmi$. . . }	= 4158.00
Solid under the After Parabolic Area $ghig$. . . }	= 3864.00
	5)34526.37
	7)6905.27
	986.46
	2
	1972.92 = Light Displacement of Canopus in Tons.

HER MAJESTY'S SHIP VANGUARD.

Load Displacement to the Constructor's ft. in. }		Tons.
Draught of Water of Afore 23 „ 0	}	(P. 97) = 3293·52
Ditto Aft 24 „ 0		
Light Displacement to the Draught of		
Water of Afore 16 „ 3	}	(P. 101) = 1891·78
Ditto . Aft 18 „ 6		
Difference		1401·74

Giving the Capacity of the Vanguard for carrying Stores, Armament, &c., as equal to 1401·74 tons.

HER MAJESTY'S SHIP CANOPUS.

Load Displacement to the Constructor's ft. in. }		Tons.
Draught of Water of Afore 22 „ 0	}	(P. 106) = 3409·08
Ditto Aft 24 „ 6		
Light Displacement to the Draught of		
Water of Afore 14 „ 3	}	(P. 110) = 1972·92
Ditto . Aft 18 „ 9		
Difference		1436·16

Giving the Capacity of the Canopus for carrying Stores, Armament, &c. as being equal to 1436·16 tons.

	Tons.
Capacity of the Canopus for carrying her Equipments =	1436·16
Capacity of the Vanguard for carrying her Equipments =	1401·74
Difference	34·42

From which result it may with justice be asserted that Her Majesty's Ship Vanguard must, under the same stowage as the French Canopus, (a smaller man of war in tonnage,) and with corresponding weights, have been deficient of the required buoyancy by at the least 270 tons, or the immersion of nearly 12 in. bodily.

PART XVIII.

Application of the Curve of Sectional Areas to the Stowage of the Hold of H. M. Ship Canopus, with Reference to the Directions given at page 21 of this work.

THE area contained between the curve a, b, c, d, e , (Plate D,) for the load displacement of the Canopus, and the curve g, h, i, k, m , for the light displacement of the same vessel, will be a representative area of the solid of displacement between those immersions of the ship, or be descriptive of the sum of the weights that will be equivalent to the upward pressure of the water between those two lines of floatation, and each portion of the area will denote the relative buoyancy of the body at that particular division or compartment of it. As an example—

Take the portion contained between the ordinates fc and zw of the curve of sections for the Canopus, (Plate D,) and the weight that would be equivalent to the upward pressure of the fluid at that compartment of the body may be determined as follows :—

See, also, for the values of fc, fl, zw , and zx , the calculations at pages 104 and 109.

By measurement, $fc = 14.12$ ft., and $fi = 9.29$ ft., and $fc - fi = ci$, is equal to the ordinate representative of the area $n o p q$ of the sheer plan of the Canopus, (Plate D,) or $fc - fi = ci$ by substitution = 14.12 ft. - 9.29 ft. = 4.83 ft.

By measurement, $zw = 13.0$ ft. and $zx = 8.6$ ft., whence $zw - zx = xw$ equals the ordinate representative of the area $r s t v$ of the sheer plan (Plate D); or $zw - zx = xw$, equals by substitution 13.0 ft. - 8.6 ft. = 4.4 ft. ;

the difference $ci = 4.83$ ft.

the difference $xw = 4.4$ ft.

Sum = 9.23 , which, divided by 2, gives

1 ft. as the mean breadth of the representative area for the compartment $c i w x$; the length between $c i$ and $w x$, or the length of the representative area for the compartment $c i w x$ 19.2 ft., whence the area $c i w x$, which is equal to the length multiplied by the breadth, equals 19.2 ft. \times 4.61 ft. = 88.512 superficial feet; and the zone or solid to that area = 88.512 \times 30 = 2655.36 cubic feet of space, which divided by 35, as the number of cubic feet of space due to a ton of medium water, gives

$$\begin{array}{r} 5)2655.36 \\ \hline 7)531.072 \\ \hline \end{array}$$

75.867 = $\frac{1}{2}$ displacement of the compartment $c i w x$ in tons, and 151.73 tons equals the whole displacement due to the portion of the immersed body situated in that compartment between the light and load draught of water. The same reasoning and similar calculations apply to the other portions of the body of the ship.

PART XIX.

A Demonstration of the Expression $\frac{2}{3} \int \frac{y^3 dx}{D}$ as being a Measure of comparative Stability or Stiffness of Floating Bodies, more usually denominated the Height of the Metacentre above the Centre of Gravity of Displacement of the immersed Portion of the Body.

FIG. 16.

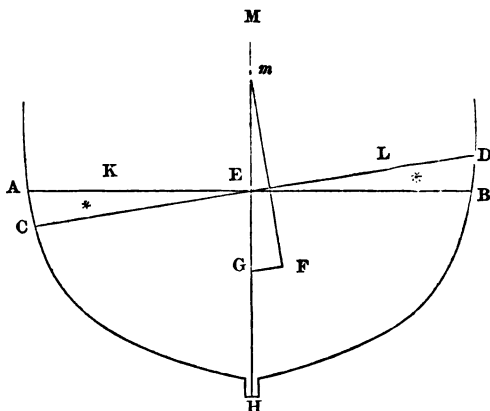

In mechanics, the removal in space of one or more bodies of a system is followed by a corresponding movement in the mass, or that the moment arising from the movement of a portion of the system will be followed by a proportionate moment of the whole. From this fundamental axiom of mechanics the following demonstration of the expression $\frac{2}{3} \int \frac{y^3 dx}{D}$ has been obtained.

In Fig. 16, ACHBD is the representative vertical and athwartship section of a floating body passing through the centre of gravity G of displacement of the whole immersed body. HM being the middle line of such section, or the common section of the plan ACHBD, with a longitudinal and vertical plane passing through the middle of the body. AB is the line of deepest immersion, or the load-water line.

Let the section assume the infinitely small inclined position which would make CD coincide with the surface of the water, the form of the section or body being such that the point E will remain unmoved, for the area ALC to be equal to the area DEB ; then, if the centre of gravity of the upright immersion, AHB , be supposed to be situated at G , the centre of gravity of the inclined immersion will be at some point F ; and if through the point F , when the position of it is determined, a line, FM , be drawn perpendicular to the line CD , the assumed line in which the surface of the water cuts the section, $ACHBD$, under its inclined position, and this line, FM , be produced to cut the middle line, HM , of the upright position of the section $ACHBD$ in the point M , that point, M , is the point termed the metacentric point to the assumed inclination.

On the supposition that the angle of inclination, AEC or DEB , represented by θ , be very small, the sides AE , EC , ED , and EB of the triangles, AEC , DEB , of the elementary prisms may be considered to be equal, and the centre of gravity of each may be assumed to be respectively $\frac{2}{3}$ of AE and ED from the point E , under which assumption AC or DB , the base of the triangles AEC , DEB , will be equal to $AE \times \sin. \theta$,

for $EA : AC = r : \sin \theta$, where if $r =$ radius unity,

$$AC = \frac{AE \times \sin. \theta}{r} = AE \times \sin. \theta,$$

and the area AEC or DEB is equal to $\frac{AE \times AC}{2}$, which by substituting in it for AC , its value in terms of AE , will become $\frac{AE \times AE \times \sin. \theta}{2}$ and if the differential of the length of the elementary Prism $= dx$, and the displacement be represented by D , and $AE = EB = CE = ED = y$, then the area AEC , or $DEB = \frac{y^2 \times \sin. \theta}{2}$ and the differential of the prismatic solid $= \frac{y^2 \times \sin. \theta \times dx}{2}$, and the centres of gravity of the triangles

A E C, D E B are respectively $\frac{2}{3}$ of E A and E D, or $\frac{2}{3} y$ from the point E, thence the horizontal moment from E of the differential of the prismatic solid, A E C, will be equal to

$$\frac{y^2 \times \sin. \theta \times dx}{2} \times \frac{2y}{3} = \frac{y^3 \times \sin. \theta \times dx}{3},$$

and the horizontal moment also from E of the differential of the prismatic solid D E B will be equal to $\frac{y^3 \times \sin. \theta \times dx}{3}$;

whence $\frac{2}{3} y^3 \sin. \theta \times dx$ will be the sum of the moments of the elementary prisms, immersed and emerged, or the moment that would arise, from the transfer of the elementary prismatic solid, A E C, considered as being concentrated in its centre of gravity, K, to the point, L, the position of the centre of gravity of the prismatic solid, D E B; which moment would produce a corresponding proportional moment in the mass D, or displacement, supposed to be concentrated in its centre of gravity, G, and which was assumed as being equal to G F. Equating these moments, we have

$$D \times G F = \frac{2}{3} \int y^3 \times \sin. \theta \, dx,$$

$$\text{whence } G F = \frac{2}{3} \int \frac{y^3 \times \sin. \theta \times dx}{D};$$

but $m G : G F = \text{radius} : \sin. \theta$, the angle $G m F$ being necessarily equal to the angle, A E C, or D E B, and thence $= \theta$ from the lines, G m and F m being severally perpendicular to A B and C D; hence, $m G = \frac{G F}{\sin. \theta} = G F$ divided by $\sin. \theta = \frac{2}{3} \int \frac{y^3 \times \sin. \theta \times dx}{D} \times \frac{1}{\sin. \theta} = \frac{2}{3} \int \frac{y^3 \times dx}{D}$; which determines the height of the metacentric point, m , above the centre of gravity, G, of the displacement.

The expression $\frac{2}{3} \int \frac{y^3 \, dx}{D}$, or the height of the metacentre above the centre of gravity of the displacement, is a measure of the stability, or of the comparative stability of two vessels, under the restriction of the inclination, being evanescent or vanishing; hence forming a practical guide only for the compa-

on of vessels whose forms, from inspection, are such as to ensure permanent stability. The calculations required to determine the stability of a floating body at finite angles of inclination are much more tedious, and the rules for them involve a larger portion of mathematical knowledge than what a novice may possess; but as these calculations test an important property of a naval construction; the equality of the volumes of immersion and emersion of the body under finite or practical inclinations, it would be better, in this rudimentary work, to have done some little beyond the boy's "first book," than to leave this element without investigation and deduction, the more especially so, from a knowledge, by past proofs, that an erroneous conception of this elementary feature of a naval construction, is too well calculated to involve the naval empirical constructor in errors, that would render the ships designed by him when considered as floating batteries very inefficient, from their uneasy movements in a sea-way, which uneasiness would be alone produced by a disregard of the effects that arise to the construction by the inequalities of the volumes of immersion and emersion. Being anxious to be clear in the definition of this matter, let it be understood, that the volume of immersion means that part of the body of the ship immediately above the surface of the water before inclination, and which is forced into the fluid by the inclining power of the sails; and that the volume of emersion, is that portion of the body of the ship which leaves the water on the inclination being given to her. With these points defined, and under the consideration that the vessel moves round her common centre of gravity, not as a fixed point but a moveable one, and that the ship, while under canvas and the consequent inclination, cannot, from such inclination, be made to increase her displacement or total weight, the actual stabilities of the two ships, Canopus and Vanguard, will be deduced from the expression and form of calculations that follow.

in the immersed volume $A R B$, which will, under the inclination, become $C R D$, and the volume represented by $C R D$, will be equal to that represented by $A R B$, the weight of the ship being the same under both positions. By this movement the prismatic solid, represented by $A L C$, which call P , will be emerged from the displacement $A R B$, and the prismatic solid $D L B$, which call Q , will be immersed to form the displacement $C R D$; under which considerations the form of the ship, immediately above and below the surface of the water, $A B$, when the vessel is upright, will materially affect the motion of the ship in a sea-way; for if the portion of the body which is immersed by inclination, as represented by $D L B$, becomes, from the form of the sides, larger than $A L C$, which is emerged, the whole body or displacement remaining the same, which it necessarily must, the weights being unaltered, it follows that there must be a constant rising of the body during the inclination produced by rolling, and a similar falling on her return to the upright position; and further, if the centre of gravity of these necessarily equal portions, viz., the volumes, immersions and emersions, should not be in the same vertical plane with each other, further defect would arise, viz., that on the inclination of the vessel, the head of her would be elevated or depressed, according as the centre of gravity of the immersed prism was abaft or before the centre of gravity of the emerged prism; the question then resolving itself into the case of increased or decreased immersions about the longitudinal axis of the vessel. Assuming the solids of immersion and emersion to be represented by Q and P , and that they be considered as concentrated in their respective centres of gravity Q and P , let the horizontal distance between the centres Q and P be taken as (b) : then the moment that will arise, from the change of the immersed body $A R B$, to that of the immersed body $C R D$, which would cause the transfer of the prism $A L C$, concentrated in P , to a similar and equal prism $D L B$, concentrated at Q , will be denoted by the product of P or Q into the distance $P Q$; or, by

substitution, $P \times PQ$ will be equal to $b \times P$, which moment of the part $A L C$ of the immersed body will produce an equivalent movement on the whole mass or solid $A R B$.

Let G (figure annexed) represent the position of the centre of gravity of the whole mass, or the ship with all her weights; F the position of the centre of gravity of the displacement, represented by $A R B$, the ship being upright; K the position of the centre of gravity of displacement, when the vessel is so inclined that the surface of the water coincides with $C D$, or when $C R D$ represents the immersed body; from K draw $K O$ perpendicular to $C D$, meeting $R O$, the vertical middle line of the body in some point O , from which construction of the figure the line $K O$ on the proposed inclination of the ship would become vertical from the points E and F , the assumed positions of the centres of gravity of the ship and her displacement; draw the lines $G E$ and $F H$ perpendicular to $K O$, and thence parallel to $C D$, or the surface of the water when the ship is inclined, and through G draw $G I$ parallel to $K O$, cutting $F H$ in the point I . Upon the ship taking the inclined position $C R D$, the point K becomes the assumed situation of the centre of gravity of the immersed body $C R D$, or the displacement, and the upward pressure of the water equivalent in force to the weight of the displacement represented by D may be supposed to act in the vertical line $K O$, to restore the ship to the upright position $A R B$, round the axis of the rotation G , the centre of gravity of the vessel; which effort can be measured by the property of the lever, by drawing a perpendicular from the centre of motion, or G , to the direction of the force $K O$, which by the construction of the figure is $G E$, whence the effort exerted by the displacement D , to restore the ship to the upright position $A R B$, will be represented by the product arising from multiplying the displacement by the perpendicular from the centre of motion on $K O$, the direction of the restoring force; or the effort of stability = displacement multiplied by $G E$ = $D \times G E$. But by the construction of the figure, $D \times$

$GE = D \times IH$, $GIHE$ being a parallelogram or the effort of stability $= D \times IH = D \times FH - FI$ as $IH = FH - FI$, whence effort of stability $= D \times GE = D \times FH - FI$, in the which OK has been assumed as the vertical direction of the upward pressure of the fluid passing through the centre of gravity of displacement. After the inclination of the vessel, it follows, that $D \times FH$ will be equal to the horizontal moment of the displacement, produced by the change of position of the immersion ARB to that of CRD ; and it is thence equal to the horizontal moment expressed by bP , and the effort to restore the vessel to the upright position, or the moment of stability as it is termed, will thence give the

$$\begin{aligned} \text{equation of } D \times GE &= D \times FH - FI \text{ or, by substitution,} \\ &= D \times FH - D \times FI \\ &= bP - D \times FI, \text{ and the sine of the} \end{aligned}$$

angle of inclination ALC , or DLB , being denoted by s ; and GF the distance between the centres of gravity of the ship, and the displacement being expressed by d , the value of FI may be determined, as $FG : FI = \text{rad.} : s$ whence taking rad. as unity $FG : FI = 1 : s$, or $FI = FG \times s = ds$, and the expression for the stability under the inclination of the angle ALC , or DLB , becomes $D \times GE = bP - Dds$, whence $GE = \frac{bP}{D} - ds$.

PART XXI.

The Volumes of Immersion and Emersion of H. M. Ships Vanguard and Canopus, calculated to an Angle of 7°.—Concluding Remarks and Observations.

THE VOLUMES OF IMMERSION AND EMERSION OF H. M. SHIP VANGUARD, WHEN INCLINED TO AN ANGLE OF SEVEN DEGREES FROM THE UPRIGHT.—PLATE F.

IMMERSION.

Vertical Section 2.

Half-breadth . . = 25·9
Perpendicular . . = 2

Divided by 2)51·8

Area of Triangle } = 25·9 ft.

EMERSION.

Vertical Section 2.

Half-breadth . . = 25·9
Perpendicular . . = 1·9

2331
259

Divided by 2)49·21

Area of Triangle } = 24·60 ft.

Vertical Section 3.

Half-breadth . . = 28·4
Perpendicular . . = 2·1

284
568

Divided by 2)59·64

Area of Triangle } = 29·82 ft.

Vertical Section 3.

Half-breadth . . = 28·2
Perpendicular . . = 2·05

1410
5640

Divided by 2)57·810

Area of Triangle } = 28·905 ft.

IMMERSION.

Vertical Section 4.

Half-breadth . . =	28·4
Perpendicular . . =	2·16
	1704
	284
	568

Divided by 2)61·344

Area of Triangle } = 30·67 ft.
of Immersion

EMERSION.

Vertical Section 4.

Half-breadth . . =	28·2
Perpendicular . . =	2·15
	1410
	282
	564

Divided by 2)60·630

Area of Triangle } = 30·315 ft.
of Emersion

Vertical Section 5.

Half-breadth . . =	27·8
Perpendicular . . =	2·1
	278
	556

Divided by 2)58·38

Area of Triangle } = 29·19 ft.
of Immersion

Vertical Section 5.

Half-breadth . . =	27·4
Perpendicular . . =	1·8
	2192
	274

Divided by 2)49·32

Area of Triangle } = 24·66 ft.
of Emersion

Vertical Section 6.

Half-breadth . . =	25·6
Perpendicular . . =	2·0

Divided by 2)51·20

Area of Triangle } = 25·60 ft.
of Immersion

Vertical Section 6.

Half-breadth . . =	24·0
Perpendicular . . =	1·7

168
24

Divided by 2)40·8

Area of Triangle } = 20·4 ft.
of Emersion

The triangular portions at the extremities of the load-water section consequent upon the inclination give the contents of ·1 of a foot for each, and thus seven areas are formed for esti-

mating the solids of immersion and emersion to an angle of seven degrees.

VANGUARD.

Immersion to Seven Degrees Inclination.

Distinguishing Number of the Areas.	Contents of the Areas.	Multipliers by the First Rule.	Multiples for the Solid.
1	.10	$\frac{1}{3}$.05
2	25.90	2	51.80
3	29.82	1	29.82
4	30.67	2	61.34
5	29.19	1	29.19
6	25.60	2	51.20
7	.10	$\frac{1}{3}$.05

$$\underline{\underline{223.45}} = \left\{ \begin{array}{l} \frac{A}{2} + 2P + Q \\ \text{of the formula.} \end{array} \right.$$

The distance between the areas is equal to 31.0 feet, whence $r = 31$ feet, which, substituted in the formula for the solid,

$$= \frac{A}{2} + 2P + Q \times \frac{2r}{3}, \text{ to sum these areas, gives } 223.45 \times \frac{62}{3} = \frac{13853.9}{3} = 4617.96 \text{ cubic feet for the contents of the}$$

solid of immersion, according to the lines of inclination on the draught when the ship is inclined to an angle of seven degrees from the upright position.

VANGUARD.

Emersion to Seven Degrees Inclination.

Distinguishing Number of the Areas.	Contents of the Areas.	Multipliers by the First Rule.	Multiples for the Solid.
1	.10	$\frac{1}{3}$.05
2	24.60	2	49.20
3	28.90	1	28.90
4	30.31	2	60.62
5	24.66	1	24.66
6	20.40	2	40.80
7	.10	$\frac{1}{3}$.05
			<u>204.28</u>

The distance between the areas as before for the immersion is equal to 31·0 feet, whence $r = 31\cdot0$ feet, and the formula for the solid = $\left\{ \frac{A}{2} + 2 P + Q \right\} \times \frac{2r}{3}$ gives $204\cdot28 \times \frac{62}{3} = \frac{12665\cdot36}{3} = 4221\cdot786$ cubic feet for the contents of the solid emerged, when the ship is inclined to an angle of seven degrees from the upright position, according to the inclined lines on the drawing, Plate F. From these calculations, viz.—

	Cubic feet.
The solid of immersion to 7°	= 4617·96
The solid of emersion „	= 4221·78
	<hr style="width: 10%; margin: 0 auto;"/>
Whence the difference	= 396·18
	<hr style="width: 10%; margin: 0 auto;"/>

or that the total displacement would under such an inclination be increased by 396·18 cubic feet; but as the total volume immersed remains the same, and the ship does not move round a fixed axis, it follows, that the tendency to increase the volume immersed by the excess of the immersed solid over the emerged, or the solid denoted by 396·18 cubic feet, will cause a rising in the whole mass, and in a sea-way where the rolling is made up of a succession of these inclinations, the reverse or a falling of the mass will take place, each time that the ship is passing to the upright position; the inclination having been assumed at 7° , the difference of the solids is nearly at the minimum, and at higher angles of rolling this effect would be found to be of a much greater magnitude, and the uneasy motion of the Vanguard in a sea-way may with justice be partly attributed to a disregard of this necessary adjustment of the form of the ship, immediately above and below the seat of water or the load-water line.

THE VOLUMES OF IMMERSION AND EMERSION OF H. M. SHIP CANOPUS, WHEN INCLINED TO AN ANGLE OF SEVEN DEGREES FROM THE UPRIGHT.—PLATE F.

IMMERSION.

Vertical Section 2.

$$\begin{array}{r} \text{Half-breadth} \quad . \quad . \quad = \quad 24\cdot6 \\ \text{Perpendicular} \quad . \quad . \quad = \quad 1\cdot9 \\ \hline \qquad \qquad \qquad \quad 2214 \\ \qquad \qquad \qquad \quad 246 \\ \hline \end{array}$$

$$\text{Divided by } 2)46\cdot74$$

$$\left. \begin{array}{l} \text{Area of Triangle} \\ \text{of Immersion} \end{array} \right\} = 23\cdot37 \text{ ft.}$$

Vertical Section 3.

$$\begin{array}{r} \text{Half-breadth} \quad . \quad . \quad = \quad 26\cdot0 \\ \text{Perpendicular} \quad . \quad . \quad = \quad 2\cdot0 \\ \hline \end{array}$$

$$\text{Divided by } 2)52\cdot0$$

$$\left. \begin{array}{l} \text{Area of Triangle} \\ \text{of Immersion} \end{array} \right\} = 26\cdot0 \text{ ft.}$$

Vertical Section 4.

$$\begin{array}{r} \text{Half-breadth} \quad . \quad . \quad = \quad 26\cdot3 \\ \text{Perpendicular} \quad . \quad . \quad = \quad 2\cdot1 \\ \hline \qquad \qquad \qquad \quad 263 \\ \qquad \qquad \qquad \quad 526 \\ \hline \end{array}$$

$$\text{Divided by } 2)55\cdot23$$

$$\left. \begin{array}{l} \text{Area of Triangle} \\ \text{of Immersion} \end{array} \right\} = 27\cdot61 \text{ ft.}$$

EMERSION.

Vertical Section 2.

$$\begin{array}{r} \text{Half-breadth} \quad . \quad . \quad = \quad 24\cdot6 \\ \text{Perpendicular} \quad . \quad . \quad = \quad 1\cdot8 \\ \hline \qquad \qquad \qquad \quad 1968 \\ \qquad \qquad \qquad \quad 246 \\ \hline \end{array}$$

$$\text{Divided by } 2)44\cdot28$$

$$\left. \begin{array}{l} \text{Area of Triangle} \\ \text{of Emersion} \end{array} \right\} = 22\cdot14 \text{ ft.}$$

Vertical Section 3.

$$\begin{array}{r} \text{Half-breadth} \quad . \quad . \quad = \quad 26\cdot0 \\ \text{Perpendicular} \quad . \quad . \quad = \quad 1\cdot9 \\ \hline \end{array}$$

$$\begin{array}{r} 234 \\ 26 \\ \hline \end{array}$$

$$\text{Divided by } 2)49\cdot4$$

$$\left. \begin{array}{l} \text{Area of Triangle} \\ \text{of Emersion} \end{array} \right\} = 24\cdot7 \text{ ft.}$$

Vertical Section 4.

$$\begin{array}{r} \text{Half-breadth} \quad . \quad . \quad = \quad 26\cdot3 \\ \text{Perpendicular} \quad . \quad . \quad = \quad 2\cdot1 \\ \hline \qquad \qquad \qquad \quad 263 \\ \qquad \qquad \qquad \quad 526 \\ \hline \end{array}$$

$$\text{Divided by } 2)55\cdot23$$

$$\left. \begin{array}{l} \text{Area of Triangle} \\ \text{of Emersion} \end{array} \right\} = 27\cdot61 \text{ ft.}$$

IMMERSION.

Vertical Section 5.

Half-breadth . . . =	24·6
Perpendicular . . . =	1·9
	2214
	246

Divided by 2)46·74

$$\left. \begin{array}{l} \text{Area of Triangle} \\ \text{of Immersion} \end{array} \right\} = \underline{23\cdot37 \text{ ft.}}$$

Vertical Section 6.

Half-breadth . . . =	23·8
Perpendicular . . . =	1·8
	1904
	238

Divided by 2)42·84

$$\left. \begin{array}{l} \text{Area of Triangle} \\ \text{of Immersion} \end{array} \right\} = \underline{21\cdot42 \text{ ft.}}$$

EMERSION.

Vertical Section 5.

Half-breadth . . . =	24·6
Perpendicular . . . =	1·9
	2214
	246

Divided by 2)46·74

$$\left. \begin{array}{l} \text{Area of Triangle} \\ \text{of Emersion} \end{array} \right\} = \underline{23\cdot37 \text{ ft.}}$$

Vertical Section 6.

Half-breadth . . . =	23·8
Perpendicular . . . =	1·8
	1904
	238

Divided 2)42·84

$$\left. \begin{array}{l} \text{Area of Triangle} \\ \text{of Emersion} \end{array} \right\} = \underline{21\cdot42 \text{ ft.}}$$

The triangular portions at the extremities of the load-water section, as in the Vanguard, on calculation, give 1 of a foot for each when, as in the case of that ship, seven areas have been calculated ; which areas, when placed in Sterling's Rule for the estimating a solid, will give the solids of immersion and emersion to an angle of seven degrees.

CANOPUS.

Immersion to Seven Degrees Inclination.

Distinguishing Number of the Areas.	Contents of the Areas.	Multipliers by the First Rule.	Multiples for the Solid.
1 .	·10	· ½ .	·05
2 .	23·37	· 2 .	46·74
3 .	26·00	· 1 .	26·00
4 .	27·61	· 2 .	55·22
5 .	23·37	· 1 .	23·37
6 .	21·42	· 2 .	42·84
7 .	·10	· ½ .	·05

$$\underline{194\cdot27} = \frac{A}{2} + 2P + Q$$

and the distance between the areas is equal to 32.5 feet = r ; which values being substituted in the formula for the solid of $\frac{A}{2} + 2P + Q \times \frac{2r}{3}$ gives 194.27 feet $\times \frac{65.0}{3} = \frac{12627.55}{3} = 4209.18$ cubic feet for the contents of the solid of immersion, according to the lines of inclination on the draught when the ship is inclined to an angle of seven degrees from the upright position.

CANOPUS.

Emersion to Seven Degrees Inclination.

Distinguishing Number of the Areas.	Contents of the Areas.	Multipliers by the First Rule.	Multiples for the Solid.
1 .	0.10	$\frac{1}{2}$.	.05
2 .	22.14	2 .	44.28
3 .	24.70	1 .	24.70
4 .	27.61	2 .	55.22
5 .	23.37	1 .	23.37
6 .	21.42	2 .	42.84
7 .	.10	$\frac{1}{2}$.	.05

$$\underline{190.51} = \frac{A}{2} + 2P + Q$$

the distance between the areas as before = 32.5 feet = r ;

whence the solid of emersion = $\frac{A}{2} + 2P + Q \times \frac{2r}{3} = 190.51$

$$\times \frac{65}{3} = \frac{12383.15}{3} = 4127.71 \text{ cubic feet of space.}$$

From which calculations, viz.—

The solid of immersion to seven degrees = 4209.18 Cubic feet.

The solid of emersion = 4127.71 „

$$\text{Difference} = \underline{81.47 \text{ Cubic feet.}}$$

The difference that was found between the solids of immersion and emersion in H. M. Ship Vanguard, under the same inclination, seven degrees, was 396.18 feet, or nearly five times

the amount of that in the Canopus, and thence is developed one cause of the easier motions of the latter ship in a sea-way.

The positions of the centres of gravity of the volumes immersed and emerged, with respect to the longitudinal axes of the ship, may be determined by the areas already calculated, the moments of them may be obtained as described for the centre of gravity of displacement, and summed by Sterling's Rules, (page 43); and should these centres not be found in the same vertical athwartship plane, there will ensue on inclination, a depression or elevation of the bow, according as the position of the centre of gravity of the immersions of the body is abaft or before that of the emersions, and it need not be dwelt much upon, when their being in the same vertical and athwartship plane is insisted on.

The solids of immersion and emersion having thus been calculated and contrasted, an adjustment of the form must take place, or the position of the point *S*, Plate F, where the inclined line denoting the surface of the water on inclination cuts the line denoting the upright position of the ship, must be changed until these volumes become equal.

When this has been effected, find the distance of the centre of gravity of each of the triangles of immersion, as *Srv*, from the point *S*, by bisecting *rv* in *w*, joining *S* and *w*, and taking $\frac{2}{3}$ of *sw* from *S* or *Sq*, giving the point *q* as the centre of gravity of *Srv*, the moment of the area *Srv* from *S* will thence be equal to *Srv* \times *Sq*; and if the moment of each triangle of immersion from the point *S* be calculated in a similar manner, and these results be placed in the rule as described (p. 43) for the displacement, the multiple of the sum of the moments of the immersed areas from the point *S* will be determined; and this result, being divided by the corresponding multiple for the solid, will give the distance of the centre of gravity of the immersions from *S*.

The centre of gravity of the emerged portion of the body

may be obtained in the same way, and the horizontal distance between these centres of immersion and emersion will give the portion b of the expression, for the measures of stability, ($b I - D d s$), as being the horizontal distance between the centres of gravity of the two solids; and half the sum of the solids of immersion and emersion will be equal to I of the same expression, whence the product of the horizontal distance that the centres of gravity of immersion and emersion are apart and the half sum of the solids will give $b I$, or the positive part of the expression, for the moment of stability; of the negative part of the expression, ($D d s$), D is known from previous calculations, being the total volume immersed; $s =$ sine of inclination also given, and d must be assumed, being the distance between the centre of gravity of displacement which is known, and the centre of the ship which can only be approximated to.*

The value of the positive part of the expression, $b i$, being reduced by the value of the negative part of the same, $D d s$ will give the value of the expression for the measure of the stability at the given angle of inclination. These calculations would have been continued out, but were considered lengthy for this small work; enough has been done, it is trusted, to enable the student to follow out the system, as the practical operations are strictly similar to those used for the development of the elements of the displacement.

In calculating the displacement from the building draught, the displacement to the outside of the plank will be closely approximated to; if the moulded displacement be calculated, from the drawing to a draught water, less than the proposed load immersion by the thickness of the plank of the bottom, as the result or moulded displacement will form the basis of a proportion to give the displacement to the outside of the

* By the ship is meant the whole mass, viz., Hull, Stores, and Equipments.

plank, as similar solids are to each other as the cubes of any one of their dimensions ; hence,

Moulded displacement will be to the required displacement as the cube of the moulded breadth : to the cube of the breadth with the plank on ; in which proportion three terms are known whence the fourth can be easily determined.

Much might be advanced with reference to the proportion that should be maintained between the lengths and breadths of ships, but in this foundation as it were of the superstructure, there are so many variations to be deduced from practice, all equally good, that it would be highly empirical, and still more unscientific, if it were attempted to set up a standard measure in this matter, but one point in forming a construction for war purposes should never be lost sight of by the naval architect—that the ship of war is intended as a floating battery, and that for efficiency the platform should afford unconfined space for the required movements of the guns mounted on it. With this fundamental axiom in view, the armament of the ship should be the first consideration, and the platform or deck for the evolutions of that armament should be described under the maximum positions of recoil and training of the guns that the naval artillerist may deem necessary for the full effect of the battery. Then let the naval architect give to this platform—for an effective training and fighting battery—a substratum or displacement that will ensure to it the power of floating at the required height above the line of deepest immersion or the load-water line.

The form to be given to that displacement, or to the ship, Practice and its adjunct, Theory, (one based on a well-digested system of practical results and facts,) must be made the means by which the desirable end may be accomplished—the perfecting of a “System of Naval Construction.”

The calculations on the immersed portions of a ship have been given in detail, and the young naval architect has been thence furnished with the means of testing the ships of the former

and the present times, by comparing the essential elements them, under a form that is novel and comprehensive. There has been no attempt in this rudimentary work to lay down laws for the construction of ships, no empirical stalking-horse has been set forth on a subject that requires the deepest thought and the greatest care, to prevent great and unnecessary National expenditure, and to avert the vexatious disappointments, which must ever attend on the faulty construction of our ships of war. And, in conclusion, should this outline of the most important branch of knowledge to Great Britain be the forerunner of larger and more useful works on the same subject, it is only to be hoped that the present one may be found a safe and useful auxiliary to them.

FINIS.

OLD

CHIT OF

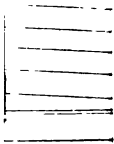

foot.

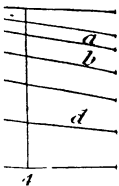
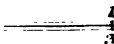

Sed

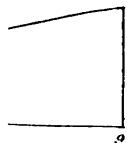

and the pres YACHT OF 36 TONS MEASURED

them, under has been no laws for the has been se thought and sary Nation pointments, of our ships of the most be the fore same subject be found a s.

Fig. Sheer

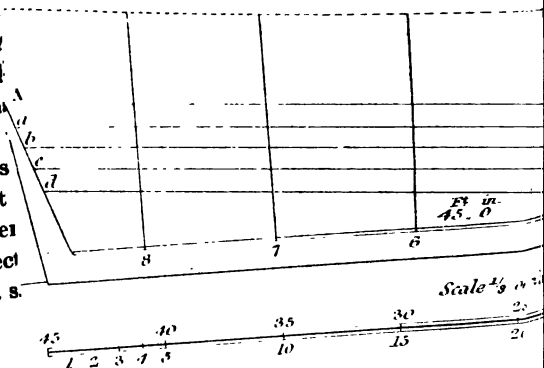

ion at 8.

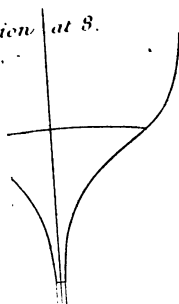

Body

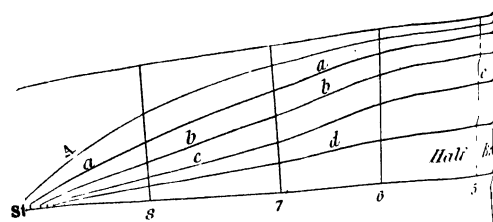
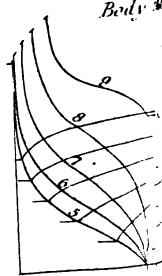

London, Published by John Wade, High Holborn, 1849

CONSTRUCTION DRAUGHT OF

Principal Dimensions

Length for Tonnage	45 0
Keel for Tonnage	36 10 ³ / ₄
Breadth for D ^r	15 6
Burthen in Tons	35 7 ¹ / ₂ ³ / ₄



A.B. Load Water line

aa } Lines parallel to
bb } AB at the distance
cc }
dd } of .92 feet apart

Side



Draught of Water

Afore	4 6
Aft	7 6

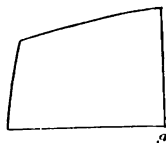

13

an
th
ha
la'
ha
th
sa
pc
of
of
be
sa
be

Ordinal 17

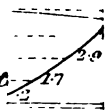

R H = 2.4

Q I = 4.1

P K = 2.11

D N = 5.8

C M = 5.0

V O = 4.2

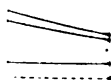

13

an
th
he
ls
ht
th
sa
pe
of
of
be
sa
be

Plate C

1/2 of an Inch to One Ton

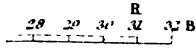

Mean Draught of Water - Amidships

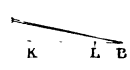
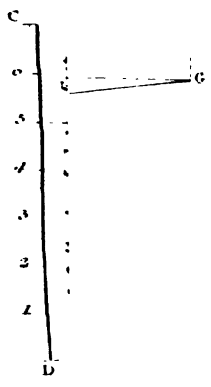

J. W. Lowry, Jr.

RUDIMENTS
OF
NAVAL ARCHITECTURE;
OR,
AN EXPOSITION
OF THE
PRACTICAL PRINCIPLES OF THE SCIENCE
IN ITS
APPLICATION
TO
NAVAL CONSTRUCTION;
COMPILED FOR THE
USE OF BEGINNERS.

BY
JAMES PEAKE,
ASSISTANT MASTER SHIPWRIGHT, H. M. DOCKYARD, WOOLWICH, AND
FORMERLY OF THE SCHOOL OF NAVAL ARCHITECTURE,
H. M. DOCKYARD, PORTSMOUTH.

London:
JOHN WEALE, 59, HIGH HOLBORN.

1851.

No 5658, 40

UNIVERSITY OF TORONTO

JUN 20 1917
TRANSFERRED TO
UNIVERSITY COLLEGE LIBRARY

212.1

PREFACE.

IN placing before the British public a rudimentary work or outline of the Practice of Ship Building, as pursued in the Naval and Commercial Dockyards of this maritime country, but little preface or apology is required, the subject itself being of such importance to England as a nation, that an attempt, however feeble it may be, to diffuse such useful knowledge, will, the author feels convinced, be received with indulgence and good-will. The best bulwarks for England have ever been found to be her Wooden Walls, and thence the alphabet, as it were, of the mechanical and practical carpentry of our national defences can never fail to excite an interest in all who bear the name of Englishman, a name carrying with it a feeling of proud and heart-felt estimation. That this small volume (completing the former volume of *Elementary Principles*) may be found useful to the youthful ship builders, who, in the course of events, must fill the stations of men who at the present period direct the Naval Architectural Department of this sea-girt island, and that it may prove instructive to the general reader, who may be under the conviction that a British Fleet must ever be the surest safeguard to his home, is the sincere wish of the author.

WOOLWICH,

May 31, 1851.

TABLE OF CONTENTS.

PART I.

	Page
Introductory Remarks, and Description of the Principal Drawing of the Ship, and the Technical Terms for the Lines depicted on it . . .	1

PART II.

Blocks on which the Ship is built.—How laid.—Description of the Frame, or the Skeleton of the Ship, as being composed of a vast assemblage of timbers.—The several Parts of the Frame described, as Keel, Stem, &c., and the Methods pointed out by which they are united	8
---	---

PART III.

Room and Space; being the Distance which the Frames are placed apart along the Keel, to form the Skeleton of the Ship	18
---	----

PART IV.

Description of the Deadwood, Apron, Stems on, Inner Post.—Cutting down of the Floors.—Raising of the Frames.—Securing of the Frames	20
---	----

PART V.

Description of the Fore Cant Timbers of the Frame.—Their Use.—Stem Pieces.—After Cant Timbers.—Changes in them in the Navy of this Country.—Keelson, or internal Keel.—Side-keelson	26
---	----

PART VI.

Fillings between the Frame of the Ship.—Introduction of them by Sir Robert Seppings.—Their intended Use.—The Methods first adopted, and those at present pursued in Her Majesty's Dockyards	32
---	----

PART VII.

Internal Trussing.—Introduction of it by Sir Robert Seppings.—Stability or Firmness of it.—Remarks on the Views taken of it by the Projector.—Former and latter Systems of Trussing the Ships of the Royal Navy contrasted	33
--	----

PART VIII.

	Page
Shelf or internal Hoop—May be considered as a Portion of the internal Planking worked to receive the Ends of the Beams.—Sections showing the relative Position of it with the Frame of the Ship.—Description of the Security used for it	36

PART IX.

Planking, or placing the Skin on the Skeleton or Frame.—Preliminary Remarks.—Description of the outside Plank, considered in the several Denominations of Wales or Bends, Diminishing Plank, Plank of the Bottom, and Garboard Strakes, with the Methods of converting and working them	38
---	----

PART X.

Inside Plank.—Description of the Limber Strakes.—Strakes over the Heads and Heels of the Frames of the Ship.—Beams.—Beams of the Ship considered as being connected with the Shelf and Waterway when the two latter are viewed as Portions of the internal Planking.—Remarks on Waterways, Clamps, Spirketting, and Trussing between the Ports	46
--	----

PART XI.

Description of the Action brought on the ends of the Beams of a Ship when rolling in a Sea.—Methods by which the ill effects of such racking or straining have been partially counteracted.—Breast-hooks and Crutches described, as formed of Iron, Wood and Iron, or wholly Wood.—Transoms, their Use	53
--	----

PART XII.

Framing the Decks or Platforms.—Mast Partners—as fitted in the British Navy—as fitted in the French Navy.—Framing to Hatchways and Ladderways.—Riding Bitts, their Use and Position.—Admiral Elliot's Bitts, where used.—Flat of the Deck.—Inner Waterways.—How secured in large Ships.—Ports.—Size, how determined.—Elevation and Depression of the Guns.—Distances between the Ports.—Limits to those Distances.—Description of the Port Lids, Half Ports, and Bucklers	57
---	----

PART XIII.

	Page
The Internal Space of the Ship.—How apportioned when fitted as a two-decked Ship of War, and appropriated to the usages of the British Navy, arranged under the several heads of Hold, Orlop, Lower or Gun Deck, Main or Upper Deck, Quarter Deck, Waist and Fore-castle, Without Board, including a few cursory remarks on the Fittings required for the sailing Evolutions of the Ship	62

PART XIV.

Measurement of a Ship or Vessel by the old Rule for Tonnage.—Rule given in detail.—Remarks on the Causes of the Rule being a faulty Approximation to the true Capacity of a Ship. — Rule practically applied to the Measurement of a Man-of-War.—Diagram showing the Method of applying the Rule	73
--	----

PART XV.

Measurement of a Ship or Vessel by the Rule for Tonnage enacted by Acts of Parliament of the Fifth and Sixth Years of the Reign of William IV.—Rule given in detail.—Rule applied practically.—The Measurement of a Vessel.—Diagram showing the Method of Application.—Necessary Deductions to be made when the Vessel measured by the Rule is to be propelled by Steam.—Short Description of a more satisfactory Method of obtaining the real Tonnage of a Ship	79
--	----

PART XVI.

Mechanical Power used for Launching.—Declivity of the Slip and Blocks on which the Vessel is built.—Sliding Ways.—Bilgeways.—Spread of them.—Inclination of the Sliding Ways.—Whether laid straight or cambered.—Ribbands, their Use.—Method practised by the French in launching.—The Method described of putting the Bilgeways on the Sliding Ways.—Stopping-up Pieces.—Poppets.—Cleats on the Bottom.—Dagger Planks.—Paying Bilgeways and Sliding Ways with Tallow.—Setting up the Ship.—Removing the Building Blocks.—Christening the Ship.—Dog Shore.—Launch of the Ship	85
---	----

PART XVII.

Docks, how situated.—Entrance, how closed.—Gates or Caissoon.—Vessel's Position on the Blocks.—Guys or Ropes, their Use.—Shores, Breast; their Use.—Vessel, Upright or Plumb.—Method of determining it.—Diagonal Shores, their Position.—Bilge Shores.—	
---	--

	Page
Blocks, their Form.—Method of removing the Angular Blocks for False Keel.—Copper Sheathing, when removed.—Places usually defective, pointed out.—Defects should be rigidly searched for previously to the commencement of Repairs.—Advantages arising from such a course of procedure.—Inside and Outside Plank, when and where to be removed.—Beams and Iron Knees to be well examined.—Rudder to be unhung.—Pintle and Braces to be overhauled.—A Plate of a Dock with Reference to these Remarks subjoined . . .	92

PART XVIII.

Principal Dimensions of the several rates of Ships in Her Majesty's Navy.—Armaments.—Weight of Anchors.—Weight of Cables.—Masts and Yards.—Weight of the Ship.—Weight of the Hull of the Ship.—Weight of the Material received on Board	99
---	----

PART XIX.

Scantlings or Dimensions of the principal Portions of her Majesty's Ships, usually termed "Scheme of Scantlings"	108
--	-----

PART XX.

Method of expanding (by means of the Sheer Drawing or Draught) the bottom of a Ship on Paper, or a Delineation of the whole Surface of the Outside of the Timbers that compose the Frame of her, a mechanical operation that enables the practical Ship Builder to arrange a disposition of the Plank and Thickstuff as a covering to the Timbers of the Ship under the Breadths, Lengths, and Positions that will be the most advantageous for Strength to the Ship and Economy in the conversion of the Store of Planking	120
---	-----

PART XXI.

Description of the Fittings to the Riding or Mooring Bitts.—Common—Elliot's.—Description of, or References to Plate 5.—Deck Hooks, how formed.—Iron Crutches.—Iron Breast-Hook.—Cleats, their Form and Uses.—Method sometimes used to secure the Frames while being hoisted into position	127
---	-----

PART XXII.

Description of the several Modes used in Her Majesty's Service for uniting the Beams to the sides of the Ship.—References to Plate 8, or a descriptive Drawing of a Compressor for the Chain Cables	131
---	-----

PART XXIII.

	Page
Capstan, or the Mechanical Power employed to raise the Anchor.— Methods used for uniting the Cable and Capstan.—Fittings of the Capstan should never be alighted, and should be well tested.—Power Capstan attained by iron Machinery, not advisable for a Man-of-War. —Plate of a common Capstan, or one on which a Messenger is used. —Plate of Brown's patent Capstan, to which the Cable is brought without the intervention of a Messenger.—References to the Plates.— Windlass	185

PART XXIV.

Rudder; its Action.—Efficient Angle to the Fore and Aft Line of the Ship.—Round-headed Rudders, when and where first introduced.— Advantages arising from the Use of them.—Subject to weakness from their Conversion.—References to Plate 9.—Description of the Rudder. —Wood-lock and Rudder.—Pendants, their Positions and Uses.— Temporary Rudders in Her Majesty's Navy	141
--	-----

PART XXV.

Remarks on the Application of Steam to the Propulsion of Ships; first, when used as a Prime Mover; secondly, when applied as an Auxili- ary to the Sails.—Description of Plate 11, or references to the Elevation, Plan, and Section of a Paddle-box of a Steam Boat.— Modes of putting the Boat into the Water, and taking it out.— References to Plate 12, or a descriptive Sketch of the Aperture for the Screw Propeller.—Mode of raising the Propeller adverted to.— Danger that would arise from a Vessel propelled by the Screw touching the ground	148
--	-----

PART XXVI.

References to Sketch 13, descriptive of some of the Ordnance employed for Naval Purposes, and of the Fittings for their Use.—Weight of Powder in Shells.—Number of Shells for close Action.—Table of Powder supplied for each rate of Ship in Her Majesty's Navy	149
---	-----

PART XXVII.

Midship Section as linearly described in Plate 2.—References to the several Portions of it, as pointing out the relative Positions, by Sec- tions, of the Timbers.—Planking, inside and out.—Beams and Decks. —Method employed if required to take off Ship when built.—	
---	--

References to Plate 4, as descriptive of the Methods which have been adopted in putting Beams together when they are composed of more than one piece.—References to a Sketch of the Deadwood of a large Frigate.—Method of making Floors in the rising Portion of the Ship's Frame.—Expansion of a common Frame of Timbers, and one composed of long and short armed Floors 1

PART XXVIII.

Description of the Method employed to remove Slack Ropes in the Tillar of Her Majesty's Ship North Star.—References to the Elevation and Plan of the Sketch, describing the Method of reaving and fixing the Tillar Ropes.—Eye Bolts for relieving Tackles, where placed . . . 147

PART XXIX.

References to the Sketches of the Head and Stern of a Frigate.—Outline of the Terms used to distinguish the several Portions of them . . . 164

PART XXX.

A short Description of the Process used to make the Seams of the Plank of a Vessel impervious to Water.—Terms of some of the Tools used for that purpose.—Scale of the Width of Seams according to Thickness.—Seams of Decks sometimes payed with Jeffery's Marine Glue.—Copper Sheathing employed on the immersed Portions of the Ships of the Navy formerly payed with Pitch and Tar.—Weight of Copper Sheathing to each superficial Foot.—Concluding Remarks . . . 169

RUDIMENTARY TREATISE

ON

SHIP BUILDING.

PART I.

Introductory Remarks and Description of the Principal Drawing of the Ship, and the Technical Terms for the Lines depicted on it.

It is to be doubted to whom the most credit pertains—to the savage who hollowed out the trunk of a tree to enable him to ensnare the finny tribe, or to the skilled artisan that has raised, piece by piece, the vast fabric which at length presents to the wondering gaze of the uninitiated that most complicated of all machines, a first-rate man-of-war; destined to carry weal or woe to all quarters of the globe. The formation of the canoe, would be to those who are cunning craftsmen in the trade, as the puny effort of the school-boy with his knife to form the model boat to carry the paper sail; and a description of the process by which the bark of the juvenile was formed to cleave the miniature waves of the mill-pond, would be, by such adepts in their art, received with smiles or contempt. The object of the present rudimentary treatise is to lead the boy from the architecture of the pond to that of the ocean; to place in his hands, in a simple and perspicuous style, the transition from the use of the knife in forming the boat, to the results arising from the skilful use of tools in shaping vast loads of rough logs or trees into the ship for War or Com-

B

merce. It should first be premised, that the ship does not swim because she is built of wood. Some woods are heavier than water, and sink when immersed in that fluid, the same as would iron. That the materials of which these floating locomotive machines may be constructed is irrespective of the property of most woods—that of swimming in water, may be inferred from the wonders of the present day, when ships may be found formed of iron that swim as buoyantly as those composed of wood, *nay, more so*; and they not only swim, but they have traversed the trackless road of the ocean, and have sailed round the world. That the materials to form a floating body are not of necessity required to be lighter than the water it is to float in, may be exemplified by the satisfactory and easily-practised experiment of making one cup of a tea-set swim within the other. In what then consists this property, as it were, of keeping its head above water? It is that of giving to the part of the body which is intended to go under water, a bulk or size that will make a cavity in the fluid, when the body is placed in it, that would contain a mass of the water equal in weight to the weight of the immersed and emerged portions of the structure. Thus, in the case of the two tea-cups, the thin lamina of clay that forms the floating cup—the outside that is immersed and the inside that is preserved from immersion by that lamina—would sink if formed into a solid square mass: the extended surface given to it makes a small immersion of it in the fluid, displace or put out of its place a body of the fluid equal in weight to the weight of the clay; and thus one cup rides as triumphantly within the other as the first-rate man-of-war does on the ocean of the world.

The draught of a ship is the delineation of the various sections of her by lines; the lines being the outer edges of such sections. To elucidate what is here meant: if an orange is cut into two parts, the edge of the peel in each of those parts will be a round or circle, and thus denote the shape of it. And if these parts be again subdivided, their outer

edges will have a similar form,—and the orange, by such a development, would be found to assimilate in form to a sphere or globe. The naval architect or constructor determines the relation which the principal dimensions of the ship, or those of the length, breadth, and depth of her should bear to each other, the form best adapted for the required service, and its capabilities; the practical ship-builder having the same relation to the naval architect that the house-builder has to the civil architect. Each of the architects is a designer in his respective science, whose designs, when completed on paper, require the able assistance of the practical man, that the one may become the graceful and symmetrical figure portrayed by a man-of-war, or the other stand forth as the stately palace of a sovereign.

The Construction-Drawing, from the sections of it being made to the outside of the exterior planking for calculation, as it comes from the hands of the naval architect, would not be available for the purposes of the practical builder, whose delineation on paper, or draught of the ship, and its consequent full development on the mould-loft floor requires to be to the outside of the timbers or inside of the exterior plank; the fact being, that the moulds, for convenience, are made to the form of the timbers only, and the timbers are trimmed by them, then put together, raised, and placed in position to receive the plank. The frame-timbers may be considered as forming ribs, to give the form of the ship, to which the planking has to be added, to give buoyancy and substance to the mass. The method of preparing the building draught of the ship from that which is furnished by the naval architect or the construction-drawing, will not be described in this work, as the process necessary to do it is more within the province of the mould-loft, and will be included in the treatise descriptive of the work done in that place.

The principal drawing of a ship, denoted the Sheer Drawing, is composed of three parts, mutually dependent on each other. They are each sectional planes considered as passing through

the largest portions of the principal dimensions of her. They are severally named—the Sheer Plan, Half-breadth Plan, and Body Plan.

The Sheer Plan is descriptive of the longest and deepest longitudinal section in the ship, or that of a plane passing through the middle line of the vessel from the middle line of the stem or fore-boundary of her, to the middle line of the stern-post or after-boundary (Fig. 1. p. 11). On this plane the position of any point in the ship may be determined for height and length, as being projected on to that plane, similar to the process followed in the delineation of a map.

The Half-breadth Plan is descriptive of half of the widest and longest level section in the ship, or that of a horizontal plane passing through the length of the ship at the height of the greatest breadth (Fig. 1). On this plane the position of any point in the vessel may be fixed by projection, as to width and length.

The Body Plan is descriptive of the largest vertical and athwartship section of the ship; forming the boundary of all the others, which are delineated within it (Fig. 1); and this plan fixes by projection the height and width of any point in the vessel.

There are thence three plans used to describe the ship, considered as a solid, or as being made up of three dimensions, length, breadth, and depth; and these are dependent on each other, as the—

Sheer plan gives the height and length.	} In which the length is common to the two.
Half-breadth gives the breadth and length.	
Sheer plan gives the length and height.	} In which the height is common to the two.
Body plan gives the breadth and height.	
Half-breadth gives the length and breadth.	} In which the breadth is common to both.
Body plan gives the height and breadth.	

To determine the true position of each point of any solid

three linear measurements are required—the height, the breadth, and the length of it, all of which must be set off from, or bear reference to, a standard plane or starting point. The plans described for the ship fully furnish these dimensions for each point in her, as they may be considered the sides, top, and ends of a block formed to the dimensions of the ship, and each point in her has double reference to the several plans, or the sheer, half-breadth, and body plans.

Thus the point in the half-breadth plan, or top of the block, if projected downwards, will meet the same representative point, shown on the sheer plan, projected inwards or athwartship: these must coincide, for they represent the same point in space, which means the same identity. This reasoning will extend itself to the rest of the linear delineation of the draught of a ship; on which, by these means, the intended form is fully described, and the internal arrangements depicted upon scale, and the practical builder has thence the whole fabric under his eye at one glance. The lines shown on the practical drawing in blue ink are called water-lines (Fig. 1, marked *a a*), forming, in the half-breadth plan, the boundaries of the several sectional areas; the upper one being the intended line of floatation, and the others being drawn parallel to it. In the sheer plan, from being the projection of these lines, their position and form is indicated by straight lines; and the height from the keel, and the relative distance from the bow or stern of any point of them, may be determined on it, but not the breadth of that point from the middle line of the ship. In fact, the sheer plan is but a surface or plane, made up of length and breadth, and cannot thence be descriptive of more than those two dimensions of the solid.

In the half-breadth plan (Fig. 1), the water-lines are descriptive of the form of the ship, as being made up of a succession of breadths of her, at the heights pointed out by the corresponding heights of the water-lines in the sheer plan,

the points denoting such breadths being in each plan at the same lengths from the bow or stern.

In the body plan (Fig. 1), the water-lines are in the form of a curve, arising from the difference of draught of water given to the ship, which causes the several points of the plane to be shown above each other in succession, beginning from forward. These heights correspond with the heights descriptive of the same points in the sheer plan, and the breadths of the vertical sections of the body plan at these assumed positions are co-equal with those of the same points in the half-breadth plan; and the young draughtsman should bear well in mind that the lines denoting the upper edge of the rabbet of the keel, middle line of the ship, both vertically and longitudinally, or the common sections of the longitudinal and vertical sections of the ship, form the bases from which the dimensions of the ship are set off, and from which, as a standard, all the other parts are measured.

A diagonal line (Fig. 1, *c*) is a curve line which bounds a section or area of the body in an oblique direction; they are drawn in red in the body plan of the draught, where they are usually made to denote the heads and heels of the timbers, and by projection they are in that plan represented by a straight line. These lines are considered the most effectual towards fairing the body of the ship, or making the one portion of her assimilate with the other. The diagonals are run off from the body plan, for the form of the diagonal section to be shown on the half-breadth plan, *c*, where it will be developed as a curve, by taking the diagonal distances along them from the middle line of the body plan to where the representative diagonal of the body plan cuts the curves which represent the respective timbers or boundaries of the vertical sections of the body; the diagonal distances thus taken being severally set off from the middle line of the half-breadth plan on the lines or stations which represent on it the positions of the corresponding vertical sections of the body plan;

such vertical sections of the body being by projection delineated by straight lines in both sheer and half-breadth plans, as shown in Fig. 1.

A curve passed through the spots thus obtained will be the boundary of a plane cutting the frame of the ship obliquely; or of a plane that, if it were hung with hinges at the middle line of the vessel, would, when allowed to fall to the given angle from the horizon, be found to coincide with the proposed form of the body of the ship: these curves give the shape of the harpins and ribbands of the practical building, which will be further adverted to in the treatise on Laying off Ships on the Mould-Loft Floor.

Buttock and bow lines (Fig. 1, marked *b*) are the boundaries of planes which are supposed to pass fore and aft through the whole length of the ship, and parallel to the middle plane of her; these lines by projection are indicated by straight lines in the body and half-breadth plans, but in the sheer plan they are curves bounding the sectional areas, and denoting by their form and regularity the symmetry of the vessel as well as the fairness of her. The buttock lines are those portions of these lines which lay towards the after-part of the ship; the bow lines those which are at the bow or fore-portion of her. The method of setting off these lines on the sheer plan is by taking off the heights in the body plan, where the straight line drawn to represent the buttock or bow line cuts the several curve lines denoting the vertical sections in it, and transferring these heights to the corresponding stations in the sheer plan, setting them up from the line which has been fixed upon to denote the upper edge of the rabbet of keel in that plan; a curve passed through the points thus obtained will be the bow or buttock line, as the case may be. The ending or termination of these lines has not been pointed out; it being more in the province of the mould-loft, and will be described in a subsequent rudimentary work, on laying off ships.

Before commencing the description of the practical carpentry

of a ship, a few words may not perhaps be misplaced, when a regret is expressed, that the profession of the naval architect and the trade of the ship-builder have been in this country at such a low ebb for many years past. Little encouragement has been given (nay, persecution has been shown) to men who had devoted their time and talents to a steady course of inductive principles to be applied to the improvement of the ships of the British navy; while imaginative and amateur constructors have basked in the full blaze of official patronage, and the treasures of England have been expended in building ships of a faulty construction or form, that may in the days of future strife tend, from their bad qualities, in no small degree to compromise the honour of the British seaman.

PART II.

Blocks on which the Ship is built—how laid.—Description of the Frame or the Skeleton of the Ship, as being composed of a vast assemblage of timbers.
—The several Parts of the Frame described, and the Methods pointed out by which they are united.

THE blocks on which the keel of the ship is laid after it is trimmed or fashioned by tools, are piles of short and thick pieces of timber, placed one above the other to a height determined by the declivity of the slip on which they are placed. The lower piece of each tier is the largest, and is termed the groundway. The upper one is called the cap of the block, and should be of free wood, easily to be split out for launching. When the vessel is built on angular blocks, the cap block for splitting out is not required, and in such instances the cap, the depth of the false keel or keels, is the one that is obtained of free-grained wood, for easy removal. Above this cap, a thickness of block, equal to the depth of the false keel or keels, is worked. The blocks have their upper sur-

faces to the inclination of $\frac{1}{4}$ of an inch to a foot, and the ship, while building, is inclined to the horizon at the angle given by such a depression. The after blocks, if above 5 feet in height, are braced together, and shored on their after-sides.

It has not unaptly been suggested that the keel may be denominated the back-bone of the ship, and that the timbers of her frame bear the same analogy to the structure that the ribs do to the human frame. The planking of the ship, under such a comparison, may with equal force be looked upon as the skin to the structure making up the fabric. The keel is usually composed of elm, a wood that is preserved by being immersed in water. The fibres of this wood are tough, and well adapted to receive the numerous fastenings or bolts that pass through it, such as the bolts through the lower timbers of the frames called floors. The size of the keel in a first-rate man-of-war is 20 inches by 20 inches, technically styled 20-inches square. The number of pieces of which it is composed in length, depends on two conditions—the length required by the draught or drawing of the ship, and the store of timber which the builder has at his command. The last condition should be kept in view by the practical shipwright throughout the whole of the mechanical operations of the shipwright carpentry. He should never lose sight of the old and trite proverb of “cutting his coat according to his cloth.” These pieces of keel, in a first-rate, rise in number to eleven or twelve or thirteen pieces; and it has been usual to have the after-one of oak. The fore-mast piece, in the Queen’s service, has the fore-end curved up to form what is called the boxing or the over-lap of the keel with the stem to unite them together, which mode of connecting one piece of timber with another is usually termed a scarph. The scarphs of the keels are locked into each other by raised and sunken portions of them, as shown by the sketch in next page.

a b the overlap or length of the scarph of the one piece of keel; *c d* the overlap of the other; *e* a sunken groove, in

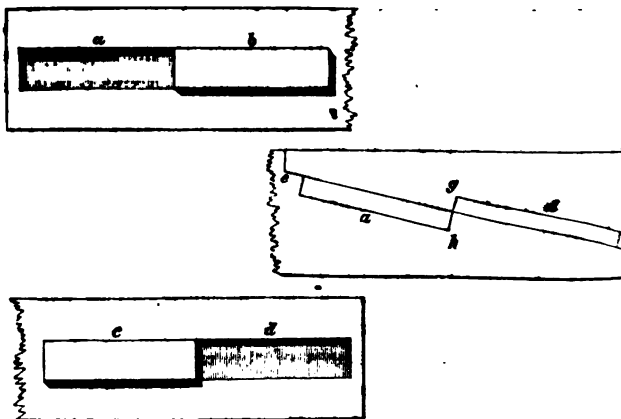

dimensions $\frac{1}{3}$ rd the width of the piece, and one-half the length of the scarp, the depth being $1\frac{1}{2}$ inch; *b* the wood left above the plain surface *ef*, equal in size to the hollow *a*; the surface of the scarp of the other piece has the raised wood at *c*, and corresponding sunken groove at *d*: when these two surfaces are brought together, the groove *a* receives the raised wood *c*, and the groove *d* receives the raised wood *b*, thus locking the two pieces of keel together, the abutment *gh* of 3 inches resisting any strain brought on the pieces of keel to pull them apart. This method of uniting is technically termed a tabled scarp; the length of the scarp is determined by the distance between the timbers of the ship, the scarp being long enough to take two of the bolts through the keelson—a timber that will be shortly described.

The rabbet of the keel or groove sunk in it to receive the plank of the bottom is usually, in the merchant service, taken out at the upper side of the keel, as shown in the sketch (Fig. 1, p. 11), and marked *abc*, leaving the depth *cd* below the plank. In the Queen's service the rabbet is brought to the lower part of the keel *f*, the lower part of the groove or rabbet being only 4 inches from *e*, or *fe* is equal to 4 inches; the rabbet on the

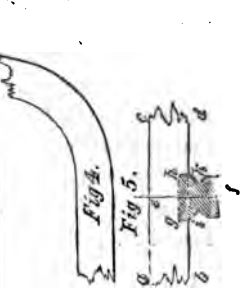
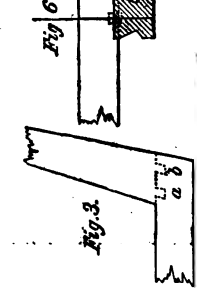
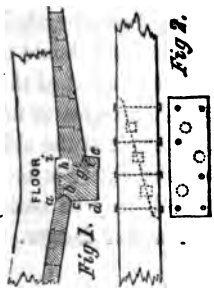
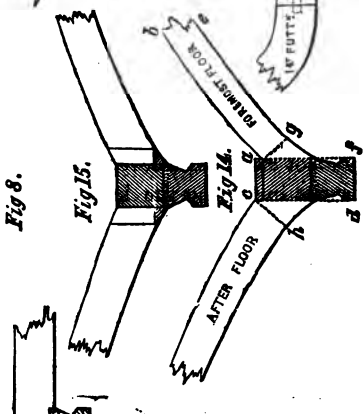
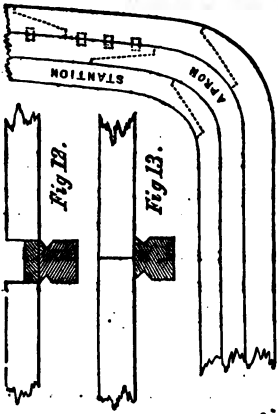
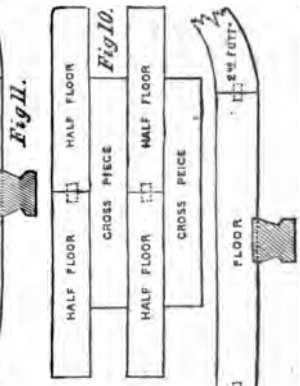
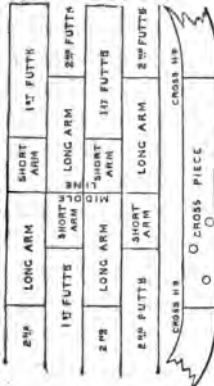
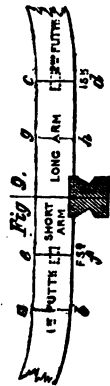

lower side, or fg , is taken out in the same way as cb of the old system; but the depth of it, fh , is increased, so that h may be within $1\frac{1}{2}$ or 2 inches of the upper side of the keel, as ih ; and the rabbet is then formed to the figure of which hgf is a section. This formation of the rabbet of the keel admits of a thick plank being worked next to the keel; and, indeed, the system thus described, of working the keel and planks of the bottom immediately in junction with the keel (technically called garboard strakes) may be said to form a combination of keel-pieces; and where strength and efficiency are more considered than expense, the safety keels of Mr. Lang, master shipwright of Woolwich Yard, will be adopted by merchant builders. In the Queen's service, the good results or safety of the ships that have in numerous instances attended on the plan has caused the system to be universally adopted. The strength which is given to the fabric by this combination of keel-pieces is not the only advantage which the system presents. In the old plan, the depth of the keel below the rabbet cd forms a lever, on the vessel taking the ground, to assist in tearing the keel out of its place. In the new plan the distance (fe) is not more than $\frac{1}{4}$ th the distance (cd), which diminishes the lever $\frac{3}{4}$ ths of its length; and, in addition, the thick garboard or keel-pieces form firmer resistance or abutments to any movement in the keel longitudinally.

FALSE KEELS.

Below the main keel, pieces of elm from 4 to 6 inches in thickness are worked of the same breadth as the keel, the whole extent of it; the butts or ends of these pieces of wood should be placed between the scarphs of the main keel: the object of this addition to the depth of the vessel is to give her a greater immersion to prevent lee-way, and that, in the event of the ship taking the ground when in shoal or shallow water, the false keel, being only slightly secured to the main keel, may be easily forced off from it and the vessel be freed from her danger.

STEM,

The foremost boundary of the ship, being a continuation of the keel to the height of the vessel at the fore extreme of her: it is usually composed of English oak timber, and receives in a groove taken out of it, technically termed a rabbet, the whole of the fore-ends of the plank of the bottom, called fore-hoods. In large vessels the stem is, from the difficulty of finding timber of sufficient dimensions, composed of three pieces, distinguished as being the upper, middle, and lower pieces of stem; these are united to each other and to the fore-end of the keel by scarphs, as described for the keel, or with coaks; the scarph which unites it with the keel being in mechanical terms denominated the boxing. (Sketch of the boxing, Fig. 8, p. 11). The stem is wider in the sided way or thickness at the head or upper part of the upper piece, the lower end of the lower piece being of the same thickness or siding as the keel at their junction. The most desirable position for these scarphs of the stem will be pointed out when the description of the construction of the frame of a vessel is farther advanced; the security of them, as restricted to the stem itself, consists of round pieces of dry wood, called coaks, and copper bolts, usually placed as described by the annexed sketch, at Fig. 2, p. 11, where the coaks are marked thus, O, and bolts o.

STERN-POST,

The after-boundary of the frame, or ribs of the ship, being the after continuation of the keel to the height of the deck, and forming, similarly to the case of the stem and planking forward, the receptacle for the after-ends of the plank of the bottom, a groove being taken out of it called a rabbet, to receive these ends, which in mechanical phraseology are termed after-hoods. The stern-post is usually of English oak, when the dimensions of it and store of timber will admit of

such a conversion, and is usually in one piece; it should be of sound quality and well seasoned. Sometimes in large vessels a false post is worked at the after-part of the main-post, to reduce the required dimensions of this portion of the frame; such conversion or provision should be avoided, if possible, the post being the foundation to which the rudder is hung, and thence requiring solidity of construction. Should it be impossible to obtain the main-post of a large ship in one, the expedient that has been sanctioned is to have the lower end scarphed, placing the outer butt of the scarph under one of the braces worked on the post, for the reception of the rudder, or for forming the hinges on which the rudder hangs. (See Rudder). The lower end of the stern-post, technically termed the heel of it, is inserted into the after-piece of keel, to which it corresponds in thickness or siding, by tenons or teeth, which fit into mortices or grooves sunk in the upper and after part of the keel to receive it.

a b tenons or teeth in the post, or mortices in the keel (Fig. 3, p. 11).

Occasionally, to assist the conversion of the timber for the post, the after length of keel, or after-piece of keel, is worked up as shown in the sketch (Fig. 4, p. 11), which is, in fact, making the after extreme similar to the fore, and decreasing the expense of the stern-post by an increase in expenditure in the conversion of the keel. The store of timber will best determine which expedient should be adopted.

There is also an inner post, which is made to succour the main-post by being brought on the fore side of it: it is dowelled to the main-post, and may be fairly considered as making up a combination of timber that would be provided in one if the trees were of sufficient size. In round and elliptical sterns, timbers called post-timbers are worked on each side of this mass of timber to form the shape of the vessel at the extreme after-part, giving to it the rake and contour of the stern.

FRAME.

The frame of the ship, or what is sometimes termed the ribs, which, as before stated, may not unaptly be compared to that part of the human frame that bears the same title, is the portion of the structure that gives the form or shape of the vessel. It is composed of numerous assemblages of timber, denominated either floors, cross-pieces, half-floors, floors short and long armed, 1st futtocks, 2nd futtocks, 3rd futtocks, 4th futtocks, 5th futtocks, top timbers; according to the carpentry that is to be used in putting the vessel together; and here the skill and ability of the practical naval architect will be evinced, as the maximum of strength and minimum of expense in the frame, under the form given to the ship, will be alone obtained by the judgment shown by the converter or cutter out in giving the best arrangement of length to the several portions of the frame or to the shift of timbers. In this stage of the work, the store of timber should be well considered and carefully examined, and probable difficulties in following up his intentions and the expense attending it, should check the views of the designer of the combination, towards completing what would seem to be the ultimatum of his wish; for maximum or greatest strength should be well weighed with the practical certainty of its accomplishment, under the resources at his command, as in most instances a trifling deviation from the design will be attended with very salutary effects on the ease of conversion and the price of the frame of the ship.

FLOORS.

In the merchant service at the present day, and formerly in the British navy, this portion of the frame, which unites the two sides of the ship, has a middle seating on the keel, by which arrangement the two arms of the floor-timber reach equally on each side of the keel.

a b c d is a section of the floor-timber, *e f* being the middle line of the ship: to give a steadiment to the floor when

placed across the keel (Fig. 5, p. 11), technically called crossing it, a piece of timber called the rising wood, a section of which, $g i k k$, is shown in the Fig., is worked, to allow of a score or groove being taken out of it; a corresponding one is sunk in the seat of the floor, the double score being sufficiently deep to insure the points i and k of the timber when let down being brought well to the upper edge of the rabbet of the keel, at i and k , that the plank may lay on the timber and the edge of it fill the rabbet. In some instances the rising wood is dispensed with, and the floor has for its steadiment a coak placed in the seating, part in the floor, and part in the keel (Fig. 6, p. 11).

In the Queen's service, or in the construction of the British navy, the practice is, to have $1\frac{1}{2}$ inch wood in the keel above the rabbet of the keel, under which system of working, $\frac{3}{4}$ ths of an inch is taken out of the keel, and $\frac{1}{4}$ th of an inch out of the seating of the floor; bringing, as in the old system, the lower side of the floor timber down to the upper edge of the rabbet of the keel, by which means the seating of the floor on the keel has $\frac{3}{4}$ ths of an inch wood to steady it. The floors are let down mostly by what is called the cutting-down staff, given from the mould-loft floor, which gives the height of the upper side of the throat of the floor at each frame. Some adopt the practice of having what is termed a seating line razed on the keel each side, as a standard to measure from, to the seating of each floor on the rising wood.

LONG AND SHORT ARMED FILLING FLOOR OF THE BRITISH NAVY.

The difficulty of the conversion for the floors on the old shift of timber has been attempted to be ameliorated, in the Queen's dockyards, by every other frame of timber, or what is termed a filling frame, being constructed as shown by Fig. 9, p. 11. Supposing $a b c d$ to be length of the floor described in the first section on floors, a half shift or butt has been adopted on the one side as pointed out by the full line, e .

the ticked line, *g h*, being the corresponding butt on the other side, giving two timbers at the middle line. This certainly would assist the conversion were all the lower timbers of the frame, floors crossing the keel; but such is not the case, only one-half being so designed. The difficulty in obtaining one-half the lower timbers of this form, combined with the conversion of the floors for the other required half, leaves no doubt that the system is attended with an increase of expense, and has not a commensurate advantage in strength.

CROSS PIECES COMBINED WITH HALF FLOORS.

Another method to unite the two sides of the frame of the ship was introduced by the late Sir Robert Seppings, formerly Surveyor of the Navy, and consisted of a cross piece or short floor across the keel, with two timbers meeting at the middle line of the vessel, denominated half floors. This plan is one uniting strength with economy, and is the combination that was used in many of the ships now in the Royal Navy. The Fig. 10 will describe the method of putting them together.

The butts of the half floors should be 2 inches alternately on either side of the middle line, to give a better space for placing the coak or dowel, which ties them to the keelson, a part of the frame which will be described in the after text. To secure the half floors to the cross piece, and to make the three timbers in their combination nearly equivalent to a solid mass, dowels, or circular coaks, were used of 3 inches in diameter and length, sunk $1\frac{1}{2}$ inch into cross piece or half floor, placed as shown in Fig. 11, p. 11.

These dowels or tenons prevent the surfaces of the cross piece and half floors from sliding over each other, while the bolts placed in each arm of the cross pieces through the half floors effectually prevent a separation of them. The heels of the half floors had also a dowel placed in them, as described in the section shown by the sketch.

1ST FUTTOCKS.

In the merchant service these timbers run down to the side of the rising wood or dead-wood, leaving a watercourse of the breadth of it or of the keel (Fig. 12, p. 11); in the Queen's service they formerly butted against each other at the middle line similarly to the half floors described in the last section, or Fig. 13.

The practice now adopted in the Queen's service is for these timbers to come to the heads of the cross pieces or floors; and dowels or tenons of hard wood are placed in the heads and heels, as shown in the sketch (Fig. 9, p. 11).

2ND FUTTOCKS.

The 2nd futtocks are placed on the heads of the half floors, and the 3rd futtocks on the heads of the 1st futtocks, the 4th futtocks on the head of the 2nd futtocks, the 5th futtocks on the head of the 3rd and the top timbers on the heads of the 4th timbers, these, with top timbers and lengthening timbers, completing the frame.

 PART III.

Room and Space; being the Distance which the Frames of the Ship are placed apart along the Keel, to form the Skeleton of the Ship.

THE distance that the frames should be apart, or the distances denoted by the equidistant straight lines in Fig. 1, p. 11, both in the sheer and half-breadth plans, requires the careful and joint consideration of the practical builder and the constructor, as having great influence on the weight of the hull and the strength of the fabric; on this essential point the aim should be to have the weight of the hull the least possible that will be compatible with the required strength,

as a diminution of the weight of it, in conjunction with the requisite firmness of fabric, will allow in the merchant service of more cargo being carried to a given or proposed draught of water, and in the Queen's service will permit of an improvement in form under a proposed displacement or total weight of the ship when equipped for sea; for the total weight of the ship, being equal to the weight of the hull, added to the weight of the provisions, stores, and equipments, a reduction of the weight of hull, one of the terms of this equality, with due regard to strength, would admit of a less displacement, which would decrease the volume immersed to the proposed draught of water, and enable the constructor to fine the form under water, whereby the propelling power of the sails would have less resistance to overcome, and the speed be increased.

The room and space given in the Queen's service varies from 2 feet 6 inches to 3 feet 9 inches, as the space to be occupied by each set of timbers called a frame, which is composed of one cross piece or one floor, two half floors, or two 1st futtocks, two 2nd futtocks, two 3rd futtocks, two 4th futtocks, two 5th futtocks, and two top timbers, with lengthening pieces as required to bring the frames to the proposed height.

The room and space has reached to the extent of 3 feet 9 inches in modern times, under the just conclusion, as before stated, that a decrease in the weight of the hull (all other weights and the form remaining the same) would insure greater speed, to which quality everything else has been made subservient. The equal spaces, when determined, are marked on the keel by a long measuring rod, called a station, or room and space staff, which is furnished from the mould-loft floor or large room, where the drawing of the ship that had been formed on the scale of a quarter of an inch to a foot, is expanded to its full size, or 48 times larger. The joint of the cross piece with the half floor, or of the floor with the first futtock, is kept well to these stations, and the frame's timbers, as they go upwards, are kept

apart from each other according to their respective sidings or thicknesses, leaving at all points equal openings; and the upper timbers being the least in size, the openings aloft are consequently the largest, but should, if the frame's timbers be well disposed, be nevertheless all equally distant from each other.

PART IV.

Descriptive of the Deadwood.—Apron.—Stemson.—Inner Post.—Cutting down of the Floors.—Raising of the Frames.—Securing the Frames.

DEADWOOD.

THE extremes of the ship, or the fore and after ends of her, having a form given to them that causes the floors' timbers gradually to become more rising or V like in appearance, which renders them first difficult to be obtained, and finally not within the natural growth of timber, it then becomes necessary to have recourse to other methods to continue the assemblage of timbers which compose the frame of a ship. The position in the length of the frame of the ship, where it would be advisable that the component shifts of timbers should be reduced by the floor, must be determined by the practical builder with reference to the capabilities of his store of timber, the half floor and the 2nd futtock of the square body being in the cant bodies cut in one length, and thence called a double futtock: having fixed that point, the deadwood becomes the foundation, against which the heels of the double futtocks and 1st futtocks are abutted. The deadwood is worked of the same width as the keel amidships, and the keel tapering at the fore and after ends, the line of the upper edge of the rabbet necessarily rises up the deadwood, to give the same breadth where the timber meets the deadwood, thus forming what is termed a bearding line.

APRON.

Within the stem, to succour it and afford wood for the reception of the plank of the bottom, and the heels of the foremost timbers, a timber called the apron is worked. The apron may be justly considered as a portion of the fore deadwood, being a continuation of it in a similar way that the stem is a prolongation of the keel; the size of it, in the sided or athwartship direction, is the same as that of the stem, and in large ships, where from necessity it is composed of two pieces, the scarph by which it is united is made to give shift to those of the stem: by shift is meant that it is placed intermediate between the scarphs of the keel and stem, to ensure the greatest strength under the required combination of materials.

The scarph of the apron is dowelled and bolted to itself at the lips or ends, the middle of the scarph being left for the bolts of the stem, and of the knee of the head to pass through. The apron is also dowelled to the stem, as shown in the sketch (Fig. 8, p. 11).

STEMSON.

The stemson is a timber worked as a further support to the stem (Fig. 8), and the three—stem, apron, and stemson—form a mass of timber that is subdivided in conversion, from the impossibility of obtaining one timber for the whole, either to the size or the curvature required.

INNER POST.

The inner post bears the same analogy to the main post that the apron and stemson do to the stem, and may be considered the continuation of the after deadwood, to form a foundation for the reception of the plank, to succour the main post, and receive the heels of the extreme after timbers. With a view to the further support of the main post, considered as being united to the inner post, and forming with it

one mass, a groove is taken out at the middle line on the fore side of the inner post; and the after end of each layer of deadwood has a corresponding tenon raised in it, which being dropped into the groove in the inner post, forms a steadiment to the two posts or mass of timber in the athwartship direction.

CUTTING DOWN OF THE FLOORS, OR THE HEIGHT OF THEIR THROATING OR UPPER SIDES OF THEM FROM THE LOWER EDGE OF THE RABBET OF THE KEEL.

e f, cutting down (Fig. 5, p. 11) of the midship floor, or height of the upper side of the floor above the rabbet of the keel.

The throating or moulding usually given to the midship floor, is once-and-a-half of their siding or thickness; and to determine the height of the cutting down, and thence throating of the foremost and aftermost floors, the scantling or size of the timber is described on the mould-loft floor, and the height is there determined that will give the moulding that is thought sufficiently strong for the ship, and practicable of conversion from the store of timber.

In the foremost floor (Fig. 14, p. 11), *g e*, is the form of the floor to the outside of the timber, as shown on the mould-loft floor, *a b* the form given to the inside of the timber ensuring the scantling or size *a g*, then *a f* becomes the height of the cutting down for the foremost floor. In the same manner the height of the cutting down (*c d*) for the after floor is determined so as to obtain the square scantling (*h c*). A batten passed through these three points, viz., the midship one, and the two fixed as here described, will give the height of the cutting down for all the floors, and, continued beyond them to the stem and stern-post, will form the height of deadwood necessary for the reception of the heels of the fore and after timbers of the frame of the ship, or those of the fore and after cant bodies of her.

RAISING THE FRAMES, OR A DEVELOPMENT OF THE FORM OF THE SHIP BY THE RIBS OR FRAMES BEING PLACED ACROSS THE KEEL.

The several assemblages of cross pieces and half floors, floors, and 1st futtocks, or long and short arm floors, as the practical carpentry may be, are first what is technically called **crossed**, that is, placed athwart the keel at their respective stations. They are let down to their cutting downs by means of the depths given from the mould loft, on what is termed a cutting-down staff, and they are squared across the keel by using a long staff as a measure from the middle line of the keel to a given station on each arm of the floor or half floors; and to set them perpendicular to the keel, a level and plumb is used, by having a long straight batten placed from arm to arm of floor or half floor at a given mark or station.

1st. To hold them in this position, the floor ribbands, or pieces of square fir, of 5 inches by 5 inches, are then brought round the outside of the floor timbers at a given height marked on each floor arm as floor sirmark, which station is given by the moulds from the mould-loft floor, and cut in on the timbers when worked or trimmed; these secure the heads of the floors in position, and are well shored to the bottom of the slipway, the head of each shore being scored over the ribband, and a nail placed in it. The ribbands are secured to the frames in the Queen's service by eye bolts, have a screw thread in a portion of them; they were introduced into the service by Mr. Blake, late master shipwright of Portsmouth Dockyard, and are invaluable for mechanical purposes.

2nd. The assemblage of timbers composed of 1st futtocks and 2nd futtocks, &c., are put together on the ground or slipway, and bolted with frame bolts of iron to constitute each frame (see sketch, p. 25), and they are hoisted into position over the heads of their respective floors by the means of large sheers, formed of pieces of wood called hand masts;

the bag of each frame, or the curvature of it, being preserved as pointed out by the sketch (Plate 5, Fig. 9).

Section of Building Blocks, Keel, and Floor.

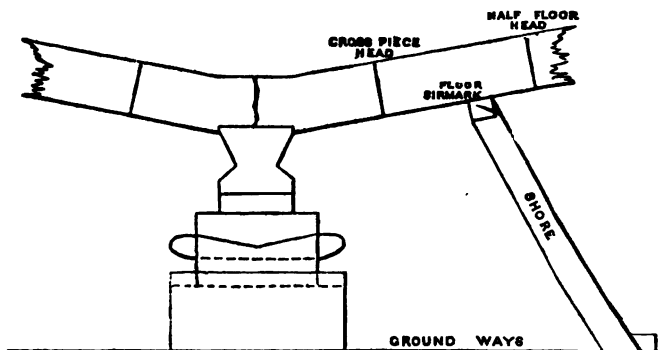

The continuations of the ribbands beyond the square frames are called harpins, and require from their curvature and form to be trimmed to receive the after and fore timbers, which are denominated cant timbers; the ribbands and harpins are sometimes scarphed to each other, but the connection is the more usually kept up by one length of the ribband being made to overrun the other.

The consecutive ends of the timbers are dowelled to each other, the dowels being 3 inches long, giving $1\frac{1}{2}$ inch into each timber thus:—

Section of the Timbers showing the Dowel.

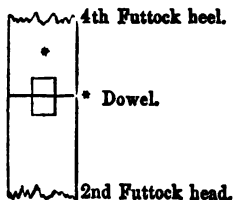

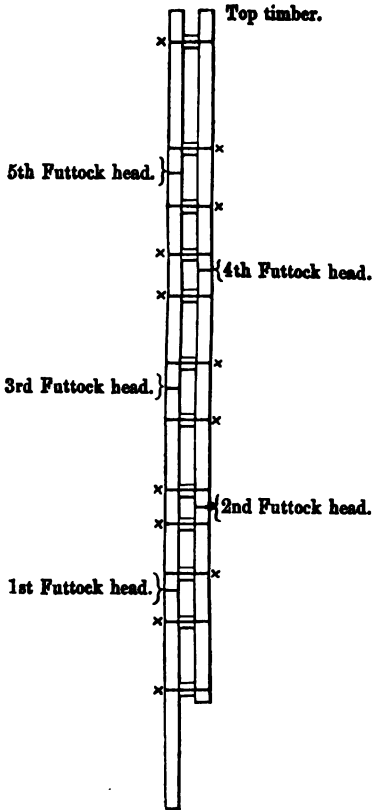

Frame Bolts and Chocks marked x.

In the merchant service, and formerly in the Queen's service, the heads and heels of the consecutive timbers are united by chocks, as shown by the sketch—thus. This method assists in the conversion of the timber, the

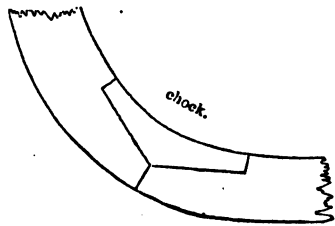

o

chock supplying the deficiency of the wood required to form the square butt; but the chocks were found to subject the frame to early decay, and a moderately increased first expense to the Government is not to be considered, when efficiency and durability is at stake. There is a difference in opinion on this arrangement, a further detail of which is not within the limits of this small work.

PART V.

Description of the Fore Cant Timbers of the Frame.—Their Use.—Stem Pieces.—After Cant Timbers.—Changes in them in the Navy of this Country.—Keelson or internal Keel.—Side Keelson.

CANT TIMBERS OF THE FRAME.

THE immersed portions of the extreme ends of a ship, or her bows and quarters, are rounded off; in the fore extreme or bow, to give the ship a form that will divide the water with ease when it is propelled by the sails; and in the after extreme, which is termed the quarters, the body immersed is made fine to allow the water to pass to the rudder in a line with the keel of the vessel, to insure the full effect of steerage or the government of her motions by the rudder, by which adaptation of form the space aloft is made considerably larger than below; under these circumstances the square timbers, or frames, that have been described, could not be continued the whole length of the vessel, with due regard to strength and economy, and thence recourse has been had to a disposition of the frame, called cant timbers, a cursory description of which arrangement will now be given.

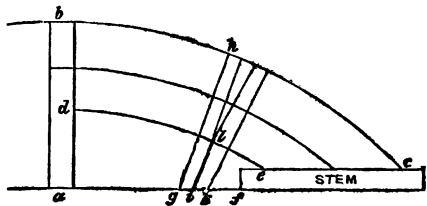

a b is the foremost square timber as it would be depicted on the half-breadth projection of the ship plan or drawing; and here, perhaps, no better illustration can be given to this mystical device of the shipbuilder, than to compare his drawings with the paper mouse-trap of our younger days; in the plaything, the succession of circles while on the surface of the card board seemed without substance or form; but by raising the internal and smallest circle we gradually drew each successive circle from the board, and a paper mouse-trap rose to our then wondering eyes. Thus it is with the shipbuilder's plans. The lines there delineated, require to be raised by the mind above the paper on which they are drawn to the required distances apart, to form a diminutive representation of the vast structure which it is now attempted to make familiar to the uninitiated, and to place the practical carpentry of it within the intelligence of the school-boy.

With respect to the cant timbers, or the filling of the space between the square frame *a b* and the stem at *c*, it may be compared to the staves of half a cask, or that departing from the direction of the sides of the timbers which form the square or athwartship body, and which timbers have their sides vertical and athwartships; the cant timbers, keeping their sides still vertical, have gradually to be inclined to 90° , or a quarter of a circle, to meet the stem, the plane of whose sides or siding way is fore and aft; the heels of them also have a less space, as *af*, for their reception, which causes the practical builder to reduce the cant timbers in their siding or thickness at the heels, to make them close joints, or, indeed, angle against each other, from a given point, taking the wood away partly from each. Thus at *gh* they are made to cross on *de*, at some point *l*, or to open at an angle both ways from that point, the heels of each at the deadwood being reduced by the substance, that the directions of the timbers give, in crossing each other at the deadwood, as *il*.

Against the stem it is usual in the Queen's service to work an angled or snaped timber called the stem piece, having for

its object the increasing the distance between the knight-heads, or first cant timbers on each side from the stem. The knightheads form the sides of the seat or bed for the reception of the bowsprit*, the stem-head forming the bed; and they would without this precaution be weakened by the hole required for the bowsprit being more in diameter than the thickness of the stem, which would deeply cut into the knightheads if the stem pieces were not worked. The next timbers to the knightheads are the hawse timbers, worked for the reception of the hawse holes; they had formerly filling timbers worked between them, with the butts of them coming in the hawse holes, to prevent (as in the case of the knightheads) their being weakened by the holes cut through them for the hawse pipes in which the cables are used. The remaining cant timbers are frames of timber only for the form and strength of the vessel.

AFTER CANT TIMBERS.

The explanation given for the disposition of the fore cant timbers will apply to all but the extreme after timbers, and here the ingenuity of the modern practical builder has been allowed to show itself in all sorts of systems. The form given to the extreme after part of the ship, in former times, was universally what is termed a square stern, and under this shape the vessels used for commerce present themselves to this day: not so in the Queen's service; there, each year of this latter age has witnessed fancied or real improvement in the stern, when attained at a vast public expense, superseded, it might almost be said, from a desire for change in the rulers of the naval dynasty of this great maritime country. And on an impartial review of the navy of this country for these 25 years past it will be found, that square sterns were pulled down to make room for circular ones, and that these

* The bowsprit is a large spar used as an out-rigger, projecting beyond the fore extreme of the ship, on which the head or foremost sails are extended or set.

circular ones in the same ships, have in their turn given way to those of an elliptical form, and the day may not be far distant when the chain of changes may be completed by a return to the original square stern.

KEELSON.

The keelson, as denoted by the name given to it, may be considered as an internal keel worked with the view of strengthening the vessel lengthways, and, in conjunction with the keel, confining the floors in their respective stations. The bolts of the keelson are driven through the throat of each floor and through the main keel. The keelson is in ships of the

Disposition of the Fastening in the Keelson.

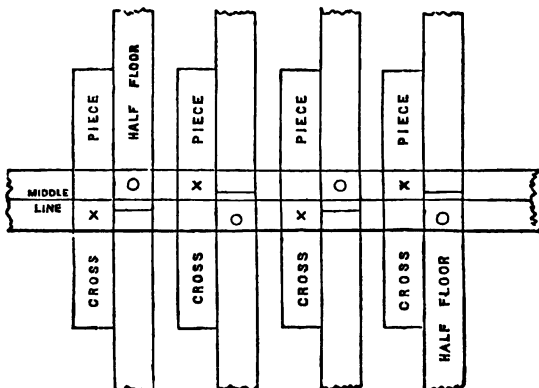

○ Coak or Dowel. × Bolt.

navy coaked or dowelled to the half floor or 1st futtock of each frame; and, for the better reception of these dowels, the half floors are not butted or joined at the middle line of the vessel, the excess being made on the alternate sides to assist in the disposal of the coaks. The keelson, in scantling or dimensions, is the square of the siding, or athwartship way of the keel, and, in the conversion of it, the lengths are determined

by a due regard to the store of timber, and the giving shift or overlaunching to the scarphs of the keel: the centres of the masts, and the fore and aftermost pieces should extend beyond the foremost and aftermost floors of the square body, to connect the keelson with the deadwood.

Sketch showing the Section of a Cross-piece, Keelson, and Half Floors.

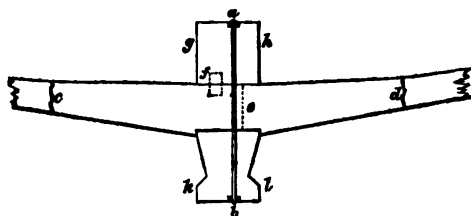

g h keelson, in form square, and in dimensions the siding or width of the keel (*k l*); *c* and *d*, the heads of the cross-piece, *e*, the butt of the half floors placed on the one side of the middle line to admit of a coak *f* in the keelson being used clear of the butt (*o*); *a b*, keelson bolt, passing through the keelson, cross-piece, and keel: the bolt should be placed on either side of the middle line for greater steadiment to the combination—the limit to the spread of the keelson bolts being such that the bolt may not break out in the rabbet of the keel. In the merchant service the keelson is bolted as described for the man-of-war, but dowels are not used, as the heels of the 1st futtocks do not come to the middle line of the vessel. The keelson bolts are of copper, and vary in diameter, according to the tonnage of the vessel, from $1\frac{1}{2}$ inch to $\frac{7}{8}$ ths of an inch. These bolts are driven on a ring of mixed metal, and the copper being beat out by driving, a head is formed larger than the ring, forming a hold when driven, beyond the friction of the bolt, which tie to the keel is completed, by the point of the bolt being spread over a ring let into the under side of the main keel;

this arrangement of the fastening unites firmly the keelson and keel together through the medium of the cross-pieces and half floors. The rings are shown in the sketch at the head (*a*) and point (*b*) of the bolt (*a b*).

Watercourses or gutters should be formed under the keelson and side keelsons, which is effected by the fillings being less moulded than the timbers. See description of Plate 2.

SIDE KEELSON.

In the Queen's service, inside the frame of the ship, abreast the main-mast and about 6 feet on each side from the middle line of the ship, timbers called side or sister keelsons are worked, the intention of them being to strengthen the ship in the immediate vicinity of the main or principal mast, the step to receive the mast resting in part on these auxiliaries to the main keelson. The lengths of the side keelsons vary from 30 to 50 feet, according to the size of the ship. The siding and moulding of them is usually 2 inches less than those given to the keelson itself; they are bolted with copper bolts through the timbers of the frame and the plank of the bottom, these bolts forming part of the fastening of the outside planking.

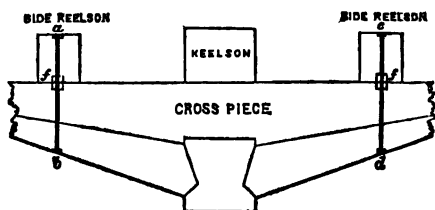

In the sketch, the sections of the side keelsons and main-keelson show their relative positions and their security through each alternate timber of the frame; *a b* and *c d* being the bolts, forming also a portion of the fastening of the bottom plank. These keelsons are also dowelled to the timbers of the

ship; the dowels, as *f*, being placed in those timbers which do not receive a bolt, and are in number such as to be from 6 to 8 feet apart.

PART VI.

Fillings between the Frame of the Ship.—Introduction of them by Sir Robert Seppings.—Their intended Use.—The Methods first adopted, and that at present pursued, in her Majesty's Dockyards.

SIR Robert Seppings, a late Surveyor of the Navy, proposed that the frames of H. M. ships, to a certain height from the keel, should be made water-tight, independently of the outside planking, to the desirable end that, in the event of the ship striking the ground, and the outside planking being forced off or being seriously damaged, the vessel would still float. In addition to the important advantages to be obtained from this mode of practical construction, as tending to the preservation of life and property, the projector had further in view the increase of strength given to the ship by her being thus made, as it were, a solid mass of material below the water. It is found in practice, from the form given to the bow and quarters under the water being fine or sharp to ensure velocity in sailing, that these extreme portions of the ship are not water borne; and that thence the midship volume displaced must, to make up the whole displacement or weight, be on the contrary greater than equivalent to the weights placed over it. The results which arise from this inequality between the superincumbent weights and the upward pressure of the water are practically evidenced by the falling of the extremes and the rising of the middle of the vessel, causing the keel of the ship after she has been some time afloat to assume a curved form, which is technically termed hogging. To take this altered position in the water, theory points out, and experience confirms, that the materials below a certain point in the depth of the vessel must have been forced into a closer contact with each other; and that thence the more dense the

materials used, and the more perfect their combination in building, the less alteration there would be in the form of the vessel when floated.

To effect this firmness of fabric, Sir R. Seppings at first filled in all the openings, below the water, between the frames or ribs of the ship, with bricks and mortar between cants of wood, and in after times with cement made of sand and water, or sand and coal-tar; but these preparations for fillings were found to be the fruitful sources of early decay to the frametimbers of the ship, and were thence abandoned; but the system was proved correct in principle, and the usual practice in Her Majesty's service is wholly to fill these openings with sound and well-seasoned fillings of wood. The fillings extend in some instances from the middle line of the ship at the keel to the load line or line of supposed deepest immersion; but they do not hold their moulding to that height, being gradually reduced in size to half the moulded breadth of the timbers at the upper line of them, they being made on the outside fair with the timbers of the frame. This gives a watercourse (Plate 2), under the internal planking, for the drainage of the water arising from leakage or otherwise to the limbers (p. 47); the main pipe, as it were, communicating with the pumps. It only remains to be added that the fillings are caulked inside and outside previously to the internal and external plank being brought on, thus making them watertight, that the vessel may float or swim should the outside planking of her be injured by the ship striking the ground.

PART VII.

Internal Trussing.—Introduction of it by Sir Robert Seppings—Stability or Firmness of it.—Remarks on the Views taken of it by the Projector.—Former and the latter Systems of Trussing the Ships of the Royal Navy contrasted.

THE late Sir Robert Seppings also introduced into the system of practical building of the ships of the Royal Navy, as

a substitute for a portion of the internal planking, a combination of wood-trussing to strengthen the ship, and illustrated the intended effect on her by a reference to the stability given to a five-barred or other gate by the bar which is placed across the horizontal portions of it. The illustration would have held good, had the strain (which he, in common with others, knew was brought on the gate) been similar to that to which his trussed frame in the hold of the ship was subjected. In the gate, the stiffness being required in the vertical position of it, the cross-bar is made wholly effective; but the same gate would be found very weak if its strength were tested by a force being applied to bend it horizontally or the flat way. This trussing frame, called by its projector a diagonal frame, was composed of timbers nearly equal in dimensions to the lower timbers of the ship, and might be justly termed an internal frame, disposed diagonally or similarly to the cross-bar of the gate, as being athwart the frame of the ship; but in the lower part or near the keelson, this trussing, in flat-floored vessels, was wholly out of comparison with the vertical position of the bar of the gate, and in those ships having a rising or sharp floor it only approximated to it. The diagonal framing thence became nearly useless as a truss, and its beneficial effects were confined to uniting the several timbers of the frame together in a longitudinal direction. This framing also, in practice, was found to interfere with the stowage in the hold; to be subject to early decay, the more especially so where old ship timber was used for this purpose, as originally suggested by the projector; and, moreover, to yield little strength to the carpentry of the ship. Such practical results, combined with some share of the love of change in the successors of Sir Robert Seppings, led to the introduction of the present mode of tying the frame timbers to each other by a succession of iron plates (Plate 2), as a substitute for the former wood frame. These iron plates vary in size according to the rate or tonnage of the vessel, their thickness being from $\frac{3}{4}$ inch to $1\frac{1}{2}$ inch, and their width from 3 inches to 6

inches; their lengths in some cases extending from within a short distance of the keelson to the top sides or upper part of the vessel*.

The mode of working these plates has been the subject of much controversy among the practical builders of the navy. In some instances they have been bent to the inside of the timbers without being inserted into them; while in others they have been buried half their thickness in the frame timbers, and, in some cases, the practice has been sanctioned of letting them in their whole thickness: but surely the insertion of them into the frame must be erroneous,—the frame of a large ship is always difficult to obtain the moulding way, and the axiom of nothing being stronger than its weakest part, would cause the practical builder to ponder well before he weakened the frame of his ship, by the score necessary to receive a plate that has little tendency, when worked, beyond the stringing, as it were, of the timbers of that frame together. These plates are bolted through the frame timbers and outside plank; and the bolts in them should form part of the regular fastening of the bottom. In small vessels these iron riders are screwed to the frame timbers by short screws, in the alternate holes; and it is advisable, in all vessels secured by this system, to work these iron riders before the outside plank is brought to, securing them temporarily with the screws; for the timbers of the frame being in some degree united by them, these plates will then prevent the edge sets used in planking, from separating the heads and heels of the several assemblages of timbers which constitute a frame or rib, and produce a desirable result; for, if such a separation takes place to any considerable extent, the stiffness of the frame is in a great degree destroyed, as the heads and heels

* The iron plates or riders at the top sides should be reduced in thickness, in the midship portion of the ship; and at the extremes, or the bows and quarters of the vessel, both upper and lower riders should be reduced both in thickness and width, to obtain the advantage of strength, combined with lightness in the hull of the ship.

can then, and will, work over each other when the ship is acted on by the force of the sea.

Sketches showing a compartment of the diagonal frame or iron truss frame of the present time are subjoined (Plate 2).

In the merchant service this system of truss frame has never been generally adopted, from the great additional expense attending its use; but in the year 1822 two vessels were built by Messrs. Gordon of Deptford, having the principle of wood trussing applied to their practical building under a most advantageous form. A system of trusses was placed between the lower and upper decks, where the sides of the ship were quite straight in the fore and aft way, and vertical in the up and down. The body was thus made, as it were, rigid or immovable to change of form at that part, and the rest of the structure might be considered to be secured from deflection or breaking, by being attached to the unalterable combination of this portion of the ship. The expense incurred by this system of building prevented its being followed generally in the mercantile navy; but Mr. Lang, master shipwright of Woolwich, has with great success applied the diagonal frame under the same principle to the Trafalgar and Royal Albert, first-rates, each of 120 guns, and probably Mr. Lang may have made the original application of the system to such purposes.

PART VIII.

Shelf or internal Hoop.—May be considered as a Portion of the internal Planking worked to receive the Ends of the Beams.—Sections showing the relative Position of it with the Frame of the Ship.—Description of the Security used for it.

SHELF.

At the height of the under side of the beams which receive the several decks or platforms of the ships in the Royal Navy, internal ribs of wood are worked longitudinally, the whole length of the vessel, to receive the ends of the beams, and are thence called shelves; they may be considered as portions

of the internal planking of the frame, and are usually brought about or worked, but not bolted, before the outside plank is brought to, as forming a good internal ribband, to preserve the form of the ship while the outside plank is being worked, Mr. Blake's screws being usually employed to keep it temporarily in position.

Sketch No. 1 shows the section of the frame timber, shelf, and beam, as usually practised. The shelf is composed of several lengths or shifts; the one being scarphed to the other by vertical scarphs, the length of the scarphs being governed by their being made equal in extent to two (p. 17)

Fig. 1.

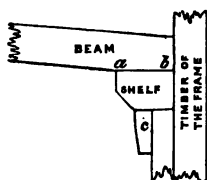
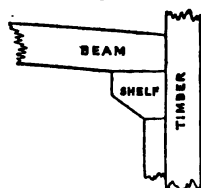

Fig. 2.



portions of the room and space given to the timbers of the frame. The scarphs are coaked or dowelled together with three dowels, and on bolting the shelf one bolt is generally placed through it at each frame timber, except forward and aft, where the distance between these bolts varies from 2 feet 6 inches to 3 feet; the upper surface of the shelf *ab*, on which the beam end rests, should be below a level, to prevent a lodgement of water. Fig. 2 is a section showing the method used by Mr. Lang, master shipwright of Woolwich Yard, in working the shelf, as doing away with the chocks, which are necessary in the plan, Fig. 1, to receive the iron knees that unite the ends of the beams to the sides of the ship (Plate 2); this arrangement will be again adverted to when that part of the structure is described. The bolts used for the shelf are of copper, varying in diameter from $\frac{3}{4}$ ths of an inch to $1\frac{1}{2}$ inch, according to the tonnage of the ship and the thickness of the body at the several portions of the same ship where the

shelf is worked. These bolts should form part of the regular fastening of the outside planking, and should be placed as nearly square to it as the nature of the work will admit; for it should carefully be kept in view that the shortest fastening through a given or fixed thickness is to be preferred, as embracing twofold advantages—that of strength, together with economy in the use of such expensive material as copper; and also, that a reduction of copper bolts in length, with no diminution in the firmness of the hull, is attended with the best result to the naval constructor—the maximum lightness of the hull of the ship. To exemplify this, the accompanying sketch is given as descriptive of the lower shelf of most ships, the shelf laying oblique to the timber of the frame.

ab the usual level bolt, cutting the outside plank obliquely.

cd the bolt placed square to the outside planking, shorter than *ab*, more square to the seating of the shelf on the timbers, and thence a stronger and cheaper fastening.

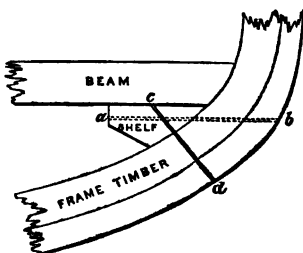

PART IX.

Planking, or placing the Skin on the Skeleton or Frame.—Preliminary Remarks.—Description of the outside Plank, considered in the several Denominations, of Wales or Bends, Diminishing Plank, Plank of the Bottom, and Garboard Strakes, with the Methods of converting and working them.

TO COVER WITH THE PLANK.

THE frame having been completed in harpins and ribbands, and the shelf worked as described, the skinning or planking of that frame is next to be accomplished. In both the merchant and Queen's services, the position of the wales

or bends, marked *n* (Plate 2), which are the thickest planks worked on the ship, is first razed on the timbers by means of long battens, technically called sheer battens, the best situation for them having been beforehand determined by the practical builder on his drawing; and it must here be advanced that the careful and intelligent practical architect will, for economy, strength, and the perfection of his work, build his vessel on paper from his drawings and from the sections he can make from those drawings. The conversant eye of a draughtsman, under such circumstances, can with advantage and accuracy scan over the miniature of the ship, as shown by his plans; he can by them determine the relative positions of the several parts of the vast fabric, and ensure to them the maximum or greatest strength of combination with the least quantity of materials. These remarks are intended to relate more especially to the fastenings which are to pass through the bottom plank of the ship, which should be wholly disposed of on paper, to avoid over fastening, which causes weakness in the vessel from two considerations—unnecessary perforation, or boring of the timbers of the frame, and the additional weight given to it, from the fastening, whether iron or copper, being in weight more than the wood taken out to receive them.

WALES AND PLANK OF THE BOTTOM.

The frame of the ship, previously to the plank being worked, should be set perpendicular by dropping a plumb-line from the centre of the cross-pauls, when the point of the brass or plumb should agree with the middle line of the ship, razed in or marked in upon the upper side of the keelson: if it should not do so, the shores placed to the ribbands should be slacked or loosened on the one side and taughtened or driven up on the other, until the point of the plumb touches the middle line before described.

The Cross Pauls are long pieces of plank which have the breadth of the ship at particular stations marked on them, and

they are secured to the timbers at their stations, to preserve the form of the ship while she remains in frame, and until the beams are crossed.

The bends or wales of the ships in the Queen's service are usually of English oak, called, in shipwright phraseology, thickstuff, running from $4\frac{1}{2}$ inches in thickness, in small vessels, to 10 inches in first-rates. A representation of the plank, or what is termed a shift of the butts of the plank, is made on paper by the draughtsman or practical builder, who, in making it, must have a cautious reference to the store of thickstuff and plank at his command before he determines the lengths of the plank or shifts to be used in building the vessel, that he may not have difficulties to overcome from the number of planks he will require of an assumed over length. The ports in ships of war will require consideration when determining the butts of the wales*. The English plank and thickstuff, from being cut out of trees wide at the butts or lower ends and narrow at the top ends, partake of the character of the tree, and thence for economy and good conversion require to be worked in a peculiar manner, denominated top and butt, or the bringing the butt of the one plank to the top of the other, to make up a constant breadth in two layers, as shown in the figure below.

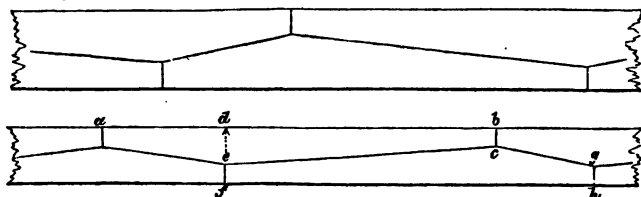

Thus in the two planks, ac and eh , the width of the two being 2 feet, it is usual to work what is called the touch (de) 15 inches, leaving the top ef of lower layer gh to be 9 inches, to complete the assumed width of 24 inches, or, if it will assist

* With reference to having each plank or shift of them in length, the space occupied by 2 or 3 ports, thence called 2 or 3 port shifts.

conversion, these may be altered to 14 inches and 10 inches, making 24 inches. The touch e is taken at $\frac{1}{4}$ th the whole length of the plank from the butt end. This arrangement gives the edges of every other plank parallel to each other, tyed fair edges. Sometimes English oak plank and thickstuff is worked what is termed Anchor Stock, but this should be resorted to only when extreme cases require it, from the extravagance of the conversion; it may, however, be worked with advantage in the channel wales of line-of-battle ships, and the spirketting of them and that of frigates.

Sketch of two Layers of Plank-worked Anchor Stock.



The thickstuff is lined for anchor-stock conversion by its being made to hold its greatest width in the middle of its length, as ef , when the width of the top end, as ac , will determine the reduction to be made in the butt end (bd), bd being made equal to ac , and the points c and f , d and f , being joined, will give the form of the plank; and the under layer will be of the same shape, giving the width of the two together as that which would result from adding the breadth which the plank will hold in the middle of its length to a similar width at the top end. This method gives also a fair edge or line for every two layers of plank worked. From the lower edge of the wales, the width of which in large ships extends to 14 or 16 strakes, the planks have to be diminished in thickness, to meet the intended or given thickness for the plank of the bottom. Thus, in the first-rate, where the wales are 10 inches in thickness and the bottom plank 5 inches, the planks following immediately under the wales have gradually to be reduced in thickness from 10 to 5 inches: the planks which are worked to effect this graduation in thickness are technically denominated diminishing stuff; and the method usually

adopted to regulate the decrease is to strike two lines as tapering lines as follows :—

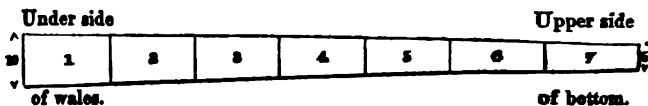

The diminishing plank being, in the Queen's service, of English oak, is worked top and butt for economy, whence each of the sections marked 1, 2, 3, &c., contains two layers of the depth, giving in this example 14 planks to effect the diminution from 10 to 5 inches, or nearly $\frac{1}{4}$ ths of an inch difference between the upper and lower edges of every two consecutive planks, or the fair edges of the planks, considered as being worked on the top and butt system.

The plank of the bottom extends from the diminishing plank to within five or six strakes of the keel, these latter being of elm, and are termed the garboard strakes; the plank of the bottom below the diminishing plank, as far as the supposed light draught of water, or the immersion of the vessel before any weights or stores are placed in her, is, in the Queen's service, usually of Dantzic oak plank, the remainder of the bottom being of fir to the garboard strakes. In the merchant service, the bottom plank is often a mixture of fir, American elm, and English elm.

The fir strakes, in the Queen's service, have invariably the after shifts or hoods of oak, for the better security of the sternpost and rudder, and the fore shifts or fore hoods are of the same material where the form of the bow requires the plank to have a great curvature or twist in it.

In working the plank of the bottom, including the wales and thickstuff, the earnest endeavour of the practical naval architect should be, for the plank to be brought to the timbers without having recourse to forcing the plank upwards to the edge of that already worked, or that which, in mechanical phraseology, is called an edge set, should be used as little as possible; it being well known in practice, that the material or planking

that would bear the bending one way, may be easily broken by an attempt to force it the cross way to that already used; and in working the plank, should the edges or the thickness of the plank be bruised, and the bruised portions of them not be removed, early decay of the plank will ensue from the injury which has been received by the grain of the wood. The best method to obtain the desirable end—that the plank should be worked to the bottom of the vessel without being crippled by edge sets, and to meet the circumstance of the girt of the midship body of the ship being so much greater, from the form given to the vessel, than those of the fore and after bodies—is, to pen or bend a broad batten round the timbers of the frame, in a longitudinal direction, as a representative of the plank, at the breadth in midships, of every six or eight strakes of plank, allowing the ends of the batten to take their own position on the timbers of the frame. This arrangement will give spaces fore and aft, considerably less than those set off and determined on amidships, as the space to be occupied by the six or eight strakes of planks, which decrease of room for the reception of the planks must be met by the fore and after shifts or lengths of plank being diminished in their width gradually, all fore and aft of their lengths; and should it be necessary, some of the shifts at the extreme ends are dispensed with, by the use of what is in ship's carpentry denominated a stealer (see Plate of Expansion of Plank). The diminution of the width of the planks at the bows and quarters assists the conversion of the plank, as it allows of plank being used, that, from having sap or unformed wood on its edges, would be unavailable for the breadth used for the midship portion of the plank of the bottom*.

* The fore and after ends of the fore and after shifts of each strake of thickstuff and plank are reduced in thickness, that they may be brought round the curved extremes of the ship with less labour, and likewise lessen the depth of the rabbet in the stern or stern post. As a general rule, the thickness of these ends may be taken at $\frac{2}{3}$ of those of the thickstuff and plank amidships, in the same strake of planking.

The plank should be well seasoned before worked, and to ensure as far as possible the durability of the ship, which would be seriously affected by the materials used in her being green, or having been provided from timber or trees lately cut down, it is highly advisable, after the plank has been hung to the frame timbers by Mr. Blake's screws, that the holes, for all fastenings that can be determined, should be bored off and left open to the draught of air that will be then drawn through them, and thus furnish the means for the internal juices of the timbers to be drawn off, and the timbers to be well seasoned.

The planking in former times was fastened to the timbers of the frame by long wooden pegs, called treenails, the practice being in large ships to place in each timber, through the planking, two of such treenails; this was technically denoted double fastening. This mode was found to weaken the timbers by what has been justly termed their being riddled or made full of holes, and this led to the system called double and single, or two treenails being placed through the one timber, while each consecutive timber had but one in it. Treenail fastening was nearly exploded from the British navy between the years 1834 to 1848, from the decay that was said to be attendant on the use of the treenail; and from the treenail being subject to be broken or upset by injudicious caulking of the seams, and thence copper bolts combined with a short mixed metal bolt-nail were introduced. The greatest evils attached to this system, are the additional weight thus given to the hull by the copper and metal, which are eight times heavier than the wood bored out for their reception; and that the metal bolt-nail has no hold in the timbers, and moreover, if not driven with judgment, has a great tendency to split the plank and cause leaks. The treenails have, under these circumstances, been again resorted to by many practical men, as yielding good fastening with lightness of hull.

See sketch, following page, descriptive of the several systems of fastenings for plank and thickstuff.

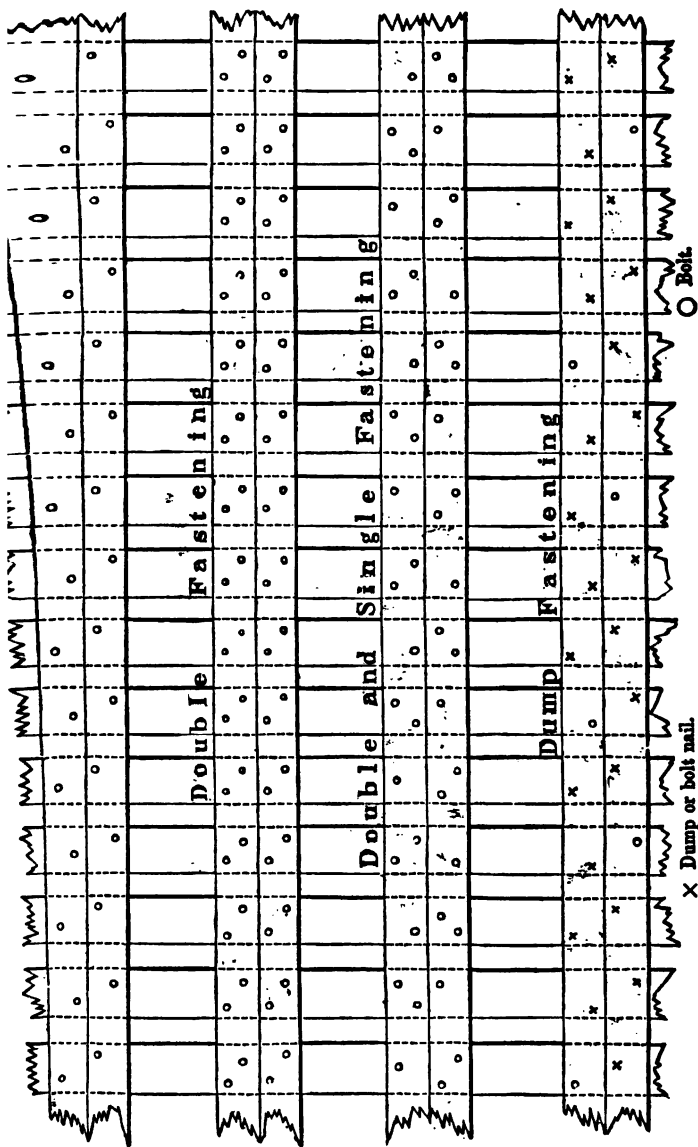

The upper strakes of the planking, or those above the water, are sometimes connected to the frame of the ship by the arrangement shown in the sketch below, and the tie thus given to the frame of the vessel and the planking is undoubtedly a good one.

b the butts of the outside planks; *a*, dowels placed in the timbers immediately adjacent to the butts, and in the planks above and below the butt, or end of the plank, the butt it-

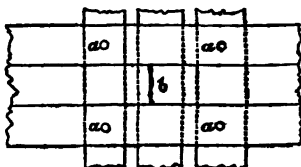

self being $\frac{1}{3}$ rd and $\frac{2}{3}$ rds on the timber to ensure wood for the reception of the butt-bolt in the $\frac{2}{3}$ rd wood, while the $\frac{1}{3}$ rd wood of the timber forms a good stop for the caulking, the other butt-bolt being placed in the adjacent timber of the frame.

Positions of the wales, diminishing planks, and the outside and inside planking are shown in the Plate (2).

PART X.

Inside Plank.—Description of the Limber Strakes, Strakes over the Heads and Heels of the Frames of the Ship.—Beams of the Ship considered as being connected with the Shelf and Waterway, when the two latter are viewed as portions of the internal Planking.—Reference to the Clamps and Spirketting.—Trussing between the Ports.

INSIDE PLANKING.

THE first band of plank from the keelson is called the limber strakes; a space being left between the side of the keelson and the lower edge of these strakes, to form, as it were, a gutter for the passage of the water arising from leakage or other causes to the pumps or pump-well. A rabbet is taken out of the lower of these strakes, of which, in a large ship, there are usually three on each side, to receive the limber

Boards or limber plates: the intention of these boards or plates is, by their forming a covering to the limbers, to keep the dirt, which unavoidably may fall into the hold in stowing the ship, out of the gutter or limbers, that it may not be drawn into the pump-well and choke the pumps; the limber plates, so called, when formed of iron, possess the additional advantage of forming a portion of the required ballast, thence giving room for cargo or stores. The depth of hold, a standard dimension of the ship, is measured from the midship edge of the lower strake of the limbers.

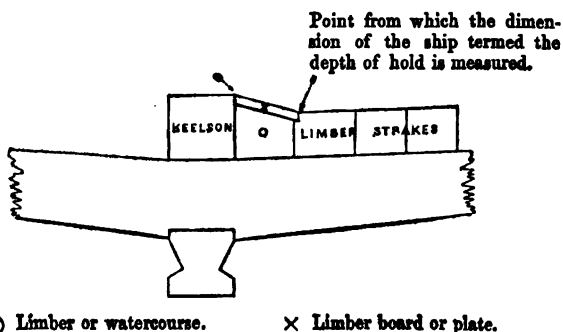

The planks worked internally, next to these, are those over the respective heads and heels of the frames; the heads and heels are marked in Plate 2, F H, I H, &c., and the planks F; and the same system should be adopted as was suggested for the working of the outside planking—that of pitching or placing them immediately over the joints of the frame amidships, and allowing the extremes to follow the directions that will admit of their being brought to the timbers without an edge set. The number of strakes over each line of heads and heels varies from two to four in midships, according to the size of the ship, and they are invariably reduced in number and thickness at the extremes or fore and after parts of the vessel, the decrease in the number of them being effected by the process styled stealers in the description of the outside planking. Between these thick

strakes it is the practice of some builders to work short lengths of plank placed diagonally, while others leave the space open; the expense incurred by filling in between these thick strakes is not repaid by commensurate strength to the ship, and increasing the number of surfaces of wood, in contact with each other, is forming so many additional causes for early decay of the ship, which should be well considered by the practical builder before he loads the hull of the ship with unnecessary wood and its consequent fastenings.

BEAMS.

The beams are placed across the ship, and in one respect may be considered as being to the ship what the rafters are to the house, the foundation to receive the floors or decks of each; but the beams of a ship are no tie to the walls or sides of her; the beams in her do not keep the sides from falling outwards or spreading; on the contrary, the direct tendency of the beams, when weights such as the guns of a man-of-war are placed on the platform or deck, which the beams support, is to bring a very considerable thrust or push on the sides of the ship to force them outwards. This is observed in practice by the falling of the beams on the quarters, or the midway between the middle line of the ship and each of her sides, and none can gainsay the fact. It would not be well, in this rudimentary work, to enter into a scientific detail of the cause of this palpable effect; but an elucidation of it may perhaps be afforded by the following simple statement:—the beams, which are placed across the ship, are set to a round or portion of a large circle, that the decks, from being laid upon them, and necessarily partaking of that round, may throw the water that may be used on them when the ship is upright, into the side, where holes, technically called scuppers, are placed to run it away. Take one of the beams thus considered as in the following sketch.

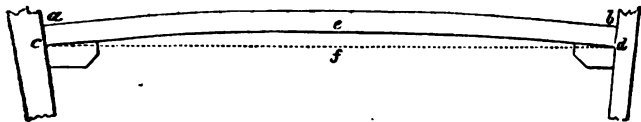

The beam $a b c d$ resting on the shelf on either side may be looked upon as an arch having for its abutments the sides of the ship at $a c$ and $b d$; the weights placed on the upper side of the beam, or such an arch $a b$, would tend to force it, having a round or pitch, $e f$, into a straight line (as $c d$), and nearly the whole strength of the arch depends upon the abutments $a c$ and $b d$; for if they be immovable, the arch can only be destroyed by the destruction of the materials of which it is composed. In the ship the abutments formed by $a c$ and $b d$ are unsupported, and have no stability in themselves, and the beams are only supported at the middle by pillars; and the results are, that on the guns or other weights being placed on the decks between the points c and e , or d and e , or on what are in nautical terms called the quarters of the beams, the round $c e$ or $e d$ drops into the straight lines $c f$ or $d f$, by the horizontal thrust of the beam forcing out the side of the ship at c and d . This must cause a weakness in the structure, which may be obviated in some measure by the under sides of the beams being made straight. The round of the decks might still be produced for the recoil of the guns and carrying off the water from the decks. The beams of small vessels admit of being provided from one piece of timber, or of being in one length; but in larger ships, their scantling, or width and depth, called in mechanical parlance siding and moulding, coupled with the lengths required, will not admit of their conversion being made in one. They are therefore composed of two or three pieces, according to the store of timber, and are scarphed together by side scarphs. The usual method in the Queen's service is to employ coaks or dowels with bolts for the security of these scarphs, as shown in the sketch, the length of the scarph being $\frac{1}{3}$ th the length of the beam (see Fig. 1, Plate 4).

The moulded way, or depth of the beam, is less than the sided way, which is the weakest form to be given to the same area of section, strength increasing with depth; but the siding being greater gives under the same quantity of wood a greater surface for the deck to rest upon. Mr. Edye, the master shipwright of Plymouth Yard, has introduced in these latter days a scarp for beams, which had its foundation in the key scarp of old date, used by the joiner or house carpenter, as also the scarp used by the shipwright to join the harpins; it is formed as shown, Fig. 3, Plate 4.

This scarp does not find many proselytes; and it is the firm conviction of the writer of this small work, that, for strength and ease of workmanship, it will be found in practice inferior to the method of scarphing where dowels are used.

WATERWAYS.

The shelf which is worked to receive the beams-ends of the several decks may also be considered as an internal hoop placed under the beams to increase the rigidity of the frame of the ship; and the waterway which is now to be described forms a similar tie on the upper side of them. The butts or ends of them, which are made unavoidable by the limits of conversion of the timber, are not scarphed or overlapped with each other as in the case of the shelf; consistency would make the practical builder forego that arrangement in the shelf, if he considers that the waterway is efficiently united without them. They are placed upon a carling between the beams; and on the decks having ports, the butts of the waterway should be under the port, to give more latitude for the butts of the spircketting, which should give good shift to the ports. The butts of the waterway and shelf partake of the same arrangement as the butts of the outside and inside planking; and there is no apparent and sufficient mechanical reason why the difficulty of conversion which attends the scarphing of the shelf, if repaid by additional strength, should not be extended to the other portions of the planking; namely, waterway, thickstuff, and the

plank of the bottom. But, on the other hand, reflection should cause the practical builder to consider all the parts of a ship as being made to succour each other, and thence not seek to complete each portion as perfect in strength of itself; and if he came to that just conclusion, the shelf would in common with other plank be worked with square butts. The waterways have been subjected to many alterations in shape and in their mode of connection with the beams. Good theoretical arrangements have been adopted to unite them firmly with the beam-ends; but these unions have depended so much on good workmanship, which could not be ensured, by even the most careful workman, from its being hidden from his view, that they would thence not be perfect even if no shrinkage took place in the wood—results that practice has proved to be beyond the skill of man and out of the course of nature. These remarks bear reference to the method of dovetailing the waterways and beam-ends, or that of letting down the waterways over the ends of the beams with a score or hole wider at the inner edge of the under surface of the waterway than at the outer edge. The most effectual way to tie the beam-end to the waterway is to dowel the two together and bolt the shelf, beam-end, and waterway together.

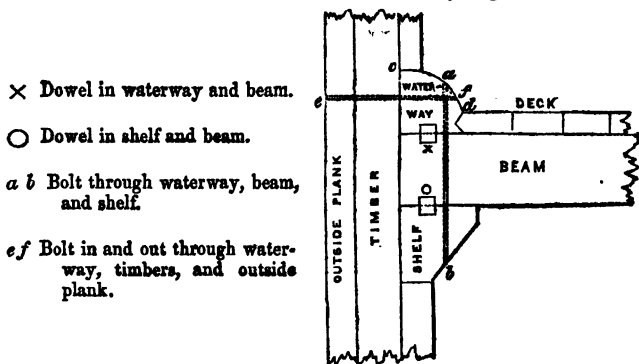

× Dowel in waterway and beam.

○ Dowel in shelf and beam.

a b Bolt through waterway, beam, and shelf.

e f Bolt in and out through waterway, timbers, and outside plank.

On the decks intended for the reception of guns, the waterway worked as above described was found materially to affect

the training of the guns, and thence the round part (*cd*), which interfered with the training or pointing of the guns, underwent a change by being hollowed out to admit of the truck or wheel of the gun-carriage being worked into it.

a is a section of the waterway, with the necessary alteration for the efficiency of the gun in men-of-war. In the merchant service, except in the larger vessels, thick waterways are not used.

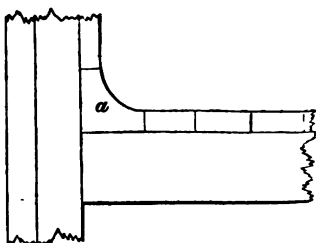

The inside planking immediately under the shelf of each deck is called the Clamps; while that placed over the waterways is distinguished by the technical term of Spirketting. As a more effectual preventive to the beam-ends rising off the shelf pieces, from any alteration in the angle made by the beam with the side of the ship (p. 49), when the vessel is rolling in a sea-way, the spirketting should be dowelled to the timbers of the frame, a practical arrangement that cannot fail to succour the waterways which form the upper abutment or resistance to any movement of the beam-ends; and in men-of-war the clamps work down to form part of the upper cill of the port; while the spirketting works up to form a portion of the lower cill of the same: both clamps and spirketting are usually bolted edgeways.

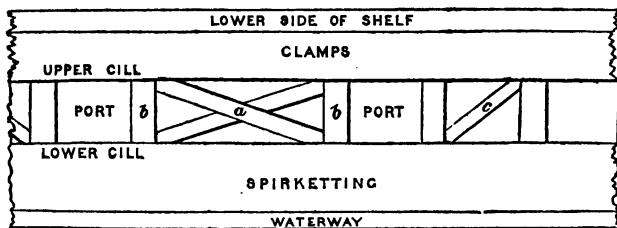

The space between the clamps and spirketting is shut in with thin planking, denominated short stuff, between the

ports. In Sir Robert Seppings' system of ship building, in this portion of the ship the short stuff was worked up as a truss-frame, abutment pieces being worked at the sides of the ports as shown by the preceding Fig., and Plate 8.

b are the abutment pieces, and *a* the truss, the section showing the direction given to the trusses placed between the ports before the middle of the ship, the truss being reversed in position in the spaces between the after ports as shown by *c* of the Fig.: these trusses were so short that little advantage was found to attend on their use, and the expense of their practical carpentry has caused their disuse.

PART XI.

Description of the action brought on the ends of the Beams of a Ship when rolling in a Sea.—Methods by which the ill effects of such racking or straining has been partially counteracted.—Breast-hooks and Crutches described, as formed of Iron.—Wood and Iron, or wholly Wood.—Transoms, their use.

SECURITY OF THE BEAMS TO THE SIDE OF THE SHIP.

A SHORT outline has been given descriptive of the beam of a ship, as being first placed on the shelf, followed by the waterway being worked above it, and then the process of uniting together the waterway, beam, and shelf; the connection of these three en masse with the frame of the ship has also been briefly pointed out, supposing the beam-ends to have no other security than these ribs of thick planks. Sufficient in strength as such a combination might prove for vessels built for commerce, it would be found wholly inadequate to the rack which is brought on the decks of a man-of-war, loaded with heavy guns, when the ship is acted on by a heavy sea, and she is propelled by such a large moving power as the sails of a vessel of war. Many have been the expedients that have been adopted to prevent the working of the beam-ends from the sides of the ship; but before any of them are given in detail, it will be well to place in a simple

and familiar point of view, the causes which produce the injurious effects which it has been the aim of all practical ship-builders to diminish in part, or, if possible, totally to counteract.

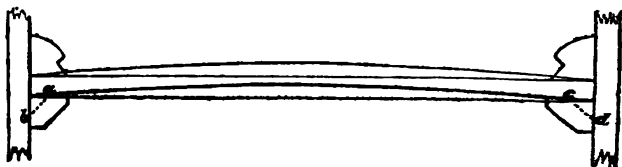

The rolling motion of the ship has been found in practice to alter the position of the beam-ends with respect to the sides of the ship, or that there is a variation in the spaces marked ab and cd , or the measures of the angles that the beams make with the timbers. The effect which is produced may be thus considered: suppose cd to be on the lee-side or side immersed, and ab to be on the weather-side, or the side that is raised out of the water in the rolling motion, there will be a strong tendency to increase the length of the line cd by the beam being raised from the shelf; while, on the contrary, there will be a similar effort to decrease the line ab by the force produced pressing down on the shelf. To resist these strains, and preserve the fastenings of the ship from being racked when subjected to them, should be the earnest endeavour of the practical naval architect. That these effects shall be wholly neutralized is beyond the skill of the shipbuilder, while the sides of a ship are left without support as described when the beams were under consideration. Several methods, or sketches of knees, will now be given by which this desirable end has in some measure been accomplished (*vide* references to Plates 6 and 7).

BREAST-HOOKS AND CRUTCHES.

To unite the two sides of the ship together at the fore and after extremes, or at the head and stern of the ship, in the cant bodies, where the floors or lower timbers do not cross

the keel, inside timbers are worked ; those forward are called breast-hooks, and the after ones crutches. These hooks and crutches have equal arms extending across the middle line of the ship, at which place, or at their throating, they are the widest, or of the most moulding. The lengths given to the arms of these hooks is determined by the store of timber, and the number of them is at the discretion of the practical builder ; they are equally spaced between the deck-hooks, which latter may be very well included under the same head with them, with this distinction, that while breast-hooks are placed square to the stem and the form of the bows, by which position they cross several timbers of the frame and tie them together, the deck-hooks must have their upper surfaces to lay with the round up of the beam, and to the sheer of the deck, and that their positions are fixed, from being at the heights of the several decks.

The difficulty which attends on the conversion of timber into breast-hooks, deck-hooks, and crutches, has led to their being in some instances made wholly of iron ; in others of a combination of wood and iron ; and yet again of wood, under an assemblage of parts or pieces. When wholly of iron they are strapped over the apron, as shown in the sketch here given.

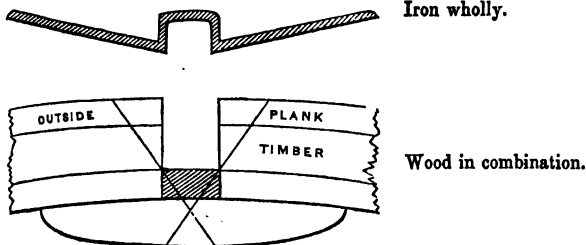
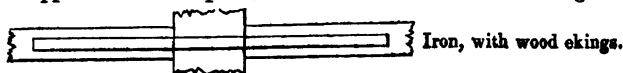

When composed of wood and iron, two arms of wood, called in the trade ekings, are worked, the upper surface of them being flush with the upper side of the apron, and on the upper side of these an iron breast-hook or plate of iron is placed and bolted through the frame-timbers and planks. When formed of wood, two ekings are worked, as pointed out in the combination of wood and iron, and then a wood hook over them, the whole being bolted to the ship's bottom.

The size of the bolts used in these ties for connecting the sides of the ship at the fore and after boundaries of her, vary in size, even in the same hook or crutch, the bolts in the throating or the widest part, being larger in diameter than those placed at the ends; and the bolts at the throat should be placed across each, as shown in the sketch, for wood breast-hooks, to bring the fastening square to the outside plank for efficiency, and to shorten the bolts for economy and lightness. The bolts should also be spaced on the upper and lower edges of the depths of these hooks; such depths being in the deck-hooks usually the moulding of the beams of the respective decks. (*Vide* also Plate 5.)

The foundations used to receive the ends of the several decks abaft, and to unite the stern to the body of the ship, are called deck transoms; they are worked in a similar method to those described as deck-hooks for the fore part of the ship. In ships with square sterns a transom called the wing transom forms the base of the stern.

PART XII.

Framing the Decks or Platforms.—Mast-partners as fitted in the British Navy.—As fitted in the French Navy.—Framing to Hatchways and Ladderways.—Riding Bitts, their use and position.—Admiral Elliot's Bitts, where used.—Flat of the Deck.—Inner Waterways.—In large Vessels, how secured.—Ports.—Size, how determined.—Elevation and depression of the Guns.—Distances between the Ports.—Limits to such.—Descriptions of the Port Lids.—Half Ports and Bucklars.

FRAMING OF THE DECKS.

THE beams of the deck having been placed across the ship, on the shelf, and the knees worked to them, with the waterways over them, the next work to be performed becomes what is technically termed the framing of the deck, or what would be called by the uninitiated the mocking out the doorways and trap-hatches. Of these, the first in consideration is the provision to be made for the security of the masts, called mast-holes. The mast-holes are larger in diameter than the respective masts at their several heights, by double of the thickness of the wedge which is considered to be sufficient for keeping the masts in position; these wedges vary in thickness from 3 inches to 6 inches, according to the size of the vessel.

The framing for a mast-hole, where deck wedges are used, is composed of fore and aft partners, cross partners, and corner chocks. The French have usually the cross partners of the foremast on the several decks shifting or movable; thus providing for an alteration in the position of the foremast without much expense being incurred; the fore-step, or where the heel of the foremast is supported, being so framed as to admit, within certain limits, of a corresponding movement.

The hatchways, or doorways from one deck to the other, are formed of four pieces; the two placed fore and aft are technically called coamings, while those athwartship are denominated head ledges. The head ledges rest on the beams,

and the coamings have pieces of wood called carlings placed under them, reaching from beam to beam.

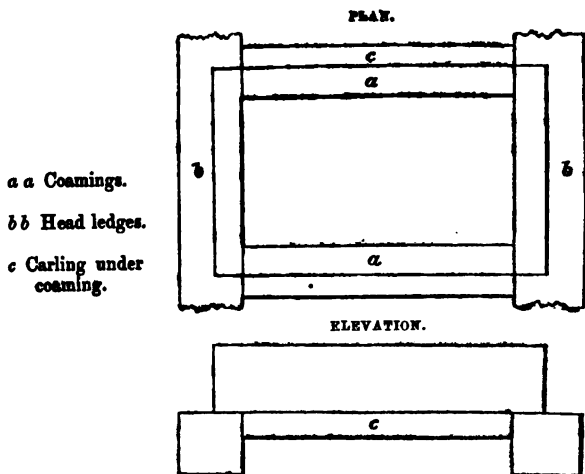

The carling (*c*) is worked 2 inches wider than the coaming, to form a support to the strake of deck-flat that comes on it. The head ledges and coamings are dowelled and bolted to the beams and carlings. Their height above the beam is such as will prevent the sea, if it should be shipped or taken on board, from rushing into the hold of the ship. The coamings have a rabbet or groove taken out of them to receive gratings that are placed over the hatchways, to give a free passage across them in time of action.

The ladder ways are framed in a similar manner, and on the deck exposed to the weather there are skylights and framings for the galley or cooking range worked on a similar system; but these minor points can only be alluded to, in a rudimentary work of this size.

RIDING BITTS.

These may with propriety be included in the framing of the decks. They are placed forward to receive the cable when the

vessel is riding by her anchor, or held from movement by the anchor, and are thence called riding bitts. In H. M. Navy, from the line-of-battle ship down to the small frigate, there are four riding bitts; or, as it is usually termed, there are two pairs of riding bitts, such bitts being on the deck immediately above the water, as the lower deck of the line of battle ships and the upper deck of the frigate. The brigs and flush deck vessels have only one pair of riding bitts.

The bitts run through two decks (see sketch, showing plan and fittings of riding bitts), and are succoured by a standard secured to them by bolts, dowels, &c., as shown; the cross piece completes the holdfast for the cables. Sometimes, where the deck is confined in space for the working of the guns, the arming of the bitts and the form of the standards to them are worked on a plan suggested by Admiral Elliott. This method of securing the bitts for the reception of the cable should never be resorted to but when want of breadth in the vessel compels its use, the bitt-heads on this principle having been known to be twisted out of place by the force of the cable when being worked round them. A sketch of them is added. In the merchant service the windlass is made to answer for riding bitts, doing the double duty of a capstan and riding bitts. A description of the windlass will be given when the capstan is under consideration.

FLAT OF THE DECK.

Next to the waterway, at the side (Fig. 2), as before described, a plank 1 inch more in thickness than the intended thickness of the platform or deck is worked with one edge into a rabbet formed in the main waterway for its reception; this is called the thin waterway, the inner edge being reduced to the thickness of the deck plank; the use of the thin waterway is to receive the ends of the decks forward and aft, as shown by the sketch in p. 60. In large ships the inner waterway should be bolted with short bolts into the beam, to resist

the caulking of the seam of the thick waterway. Thickness of deck (Plate 2). (*Vide* Scheme of Scantlings.)

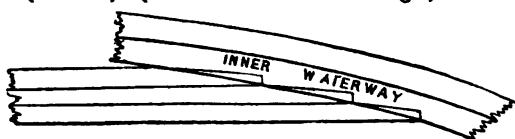

PORTS.

In a man-of-war, or a vessel intended for war purposes, the sides above the water are perforated with oblong holes denominated ports, in which the guns are worked or manœuvred, and out of which they are fired. The size of these ports or apertures is determined by the calibre of the gun that is to be used in them, and the height of the lower part of the port, or the upper side of the lower port-cill from the deck, is fixed by the height the naval artillerist gives to the centre of metal of the gun, or the middle line of the gun when it is set horizontal or point blank, when combined with the requisite depression, or that which will allow of the gun being pointed downwards to the extent considered necessary to make it efficient; after which, the depth of the ports on the several decks, or the up and down dimensions of them, is regulated by the required elevation of the muzzle of the gun above the point blank position of it. The depression and elevation considered effective in the Royal Navy of England is 7° of depression, and 9° of elevation, the quadrant being 90 of such degrees, or that portion of a circle which denotes a range of angle from the horizontal or level portion to that of the perpendicular, or what is more familiarly termed plumb. The ports are from 7 feet 6 inches to 9 feet apart, according to the views of the constructor, who should in this particular give the utmost range of which the proposed design will admit, as crowded quarters or small spaces between the guns lead to confusion in action, and possibly to casualties which if a longer and more open platform had been allowed would not have occurred; on the other hand, to this there is a limit

fixed by the desirable end that the principal dimensions of the ship should be the least possible that will carry with efficiency the armament which it has been determined she shall have on board. (*Vide* description of the Plate to Ports and Guns).

PORT LIDS.

The apertures through the sides for using the guns, or the ports, are closed up in tempestuous weather by the port lids, which on the lower decks of the large vessels of the English navy, or ships with two armed decks and upwards, are made to close the port-hole in one piece, and they are hung with hinges on the upper side, which, with the method of fitting them, is described in the drawing annexed.

- a* Port hinges of iron.
- c* Illuminator for light when the port lids are down.
- b* Scuttle in the port, to allow of the rammer for loading the gun to be out in bad weather.
- d* Ring bolts to receive the port pendants, or the rope or chain to raise the port lids.
- ee* Rings. Bolts on the inside of the port to bar them in by.

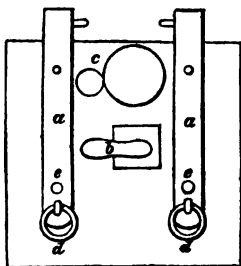

Air scuttles, invented by Mr. Lang, of Woolwich Yard, are now fitted between the ports, in lieu of the illuminator (*c*).

On the upper deck of line-of-battle ships, and main-deck of frigates, the ports are in two parts; the lower one hung with hinges on the lower part of it, called a bucklar, and the upper part a half port to put in by hand.

PART XIII.

The Internal Space of the Ship ; how apportioned when fitted as a two-decked Ship of War, and appropriated to the usages of the British Navy, arranged under the several heads of—Hold ; Orlop ; Lower or Gun Deck ; Main or Upper Deck ; Quarter Deck, Waist, and Forecastle ; Without Board ; including a few cursory remarks on the Fittings required for the Sailing Evolutions of the Ship.

THE numerous fittings of a man-of-war will next be given, although much of the finish of the hull of the vessel has necessarily been omitted, from the restricted space afforded in this rudimentary volume for the details of such a vast and complicated structure as a first-rate man-of-war. The prominent features of the vessel have been briefly described ; if even such, had been attempted for the minutiae of it, this small volume would in bulk have greatly exceeded its limits.

The inside of the ship having been apportioned into divisions or floors by means of the several decks or platforms, these again are subdivided each within themselves, and appropriated respectively to the accommodation of the officers and men, to the stowage and keeping of the water, powder for the use of the great guns and small arms, and provisions for the ship's company, and the stores requisite for service at sea. This internal arrangement admits of much controversy, and rival constructors and most naval commanders have their own opinions on the most advantageous position for the weights the ship has to receive on board. In this elementary work, an opinion of the merit or demerit of particular plans for stowage ought to have no place ; but it may be considered within its limits if the hint is advanced, that in disposing of the several portions of the floors or decks, due regard should be paid to the use to which it is intended to apply them. As an instance, in the main hold, or store-room for water, care should be observed that the bulk heads, or what may be considered the walls of it, should be sufficiently far apart to allow of there being stowed between them without overlength a

Certain number of iron tanks for holding the water; the tanks denominated 2-ton tanks are in length from out to out 4 ft. 1½ inch; the hold should thence be in length a multiple of 4 feet 1½ inch, so as to take in four, five, or six, &c., lengths of tanks, and have no broken stowage. The same rule should be observed in the provision rooms that are stowed with casks, and the naval constructor will be more likely to succeed in his design when a system is pursued by him in such measures.

HOLD.

The hold is the internal lower part of the shell or hull, and is wholly taken up as a deposit for provisions, water, and stores. The divisions of it in a man-of-war may be classed as follows; premising that the bulk heads by which the compartments are formed are made of 3-inch plank, sometimes worked up and down, at other times athwartships with stantions; but in both instances coming to a beam. Commencing then from forward, the store rooms of the gunner, boatswain, and carpenter, or warrant officers, are placed; within which are the sides of the fore magazine or powder store, and its light room or room to receive lamps to light the magazine. Next aft to these comes a coal-hole, then the fore and main holds for the water tanks, inclosing the pump well or space for the reception of the pumps, and lockers or boxes for chain cables and shot, which are thence centred round the main or principal mast; such being the position given to them to concentrate the weights for the easy motion of the ship in pitching against a head sea. The after hold next follows, in which is placed what are technically called the wet provisions, or beef and pork in brine, inclosed in casks; the portion of the hold next to this receives the dry provisions, namely, oatmeal, peas, cocoa, &c.; while aft again of it is the spirit room, or store for the rum and wine for the ship's company, and then there is usually a coal-hole, inclosing the after magazine or store of powder for the guns at the after part of the ship; and the extreme after part, which now alone requires to be alluded to, is

reserved for the bread room, in which the biscuit is stored in bags containing 2 cwt. each, and occupying a space of at least 5 cubic feet each bag. In latter days, to form some protection to the powder magazines from shells, when fired by an enemy in action, water in tanks is placed round the sides of them.

ORLOP.

Leaving the hold and coming on to the orlop of a line-of-battle ship, there are, forward, the upper store-rooms of the gunner, boatswain, and carpenter,—and next aft to them, the cabins allotted to those officers as living and sleeping places. Other cabins are to be found in this part of the ship, coming on the same range, for the junior marine officer and pilot, &c. The cable tiers or store-rooms for the hempen cables follow, one on each side; the centre part between them being occupied by the sail-room, which extends from fore hatch to main hatchway, a position which facilitates the stowing or removing of the sails. There is a clear passage kept round the ship, which is called the wings, and is strictly preserved as such, to enable the carpenters of the ship in action to have easy access to the sides of the vessel to plug up the holes made by the shot of the enemy between wind and water, or at the surface of the sea, which holes would otherwise endanger the safety of the ship.

Aft of the main mast on this deck, on each side of the ship, are cabins for the officers, and store rooms for the reception of their private stock of wine, &c.; the centre part between them, which is fitted up with an amputation table, for the use of the surgeon in time of action, is called the cockpit; in this portion of the ship the midshipmen sleep in hammocks slung up, similar to those used by the seamen.

LOWER OR GUN DECK,

The platform on which the heaviest guns to be carried in the ship were formerly placed; but in modern times the use of steam vessels, a class of vessels that will in the following

ages be briefly alluded to, armed with very heavy guns, and those possessing a long range, has caused the introduction of guns of similar metal on to the weather or highest decks of the sailing ships of the line, to render them more efficient. The guns in the sailing vessels or ships of the line being on the poop and forecastle, it places them considerably above those on the deck of the steam vessel, and necessarily gives them a greater and more effectual range. On this deck are the riding bits (*vide* Plate of them), by means of which the nempen or chain cables to the anchor or anchors are attached and secured to the vessel, for riding the ship when required. At the after part of it the tillar, or governor of the movements of the vast fabric, is placed, inserted into the head of the rudder; the ropes by which the required positions of the tillar are effected being led by blocks to the steering wheel, which is placed on the quarter deck. The effective and easy direction of the intended course or road of so large a body as the first-rate man-of-war, has in all times taxed the ingenuity of the shipwright and mechanic; and thence plans have been patented and partially adopted which, in a few months, or at the most a few years, have been condemned by practice. The following method of fixing the blocks for steering a ship has been found to ensure steadiness of motion in the rudder, to prevent any sudden jerk on the wheel, and to enable the helmsman to reverse the position of the rudder immediately it is required. Assuming that the tillar is to be moved by the double rope on each side of it, passing through blocks at the end of it, the quantity of rope required under the usual fitting to string it is the most when the tillar or helm is amidships, whence any movement from the middle position of it will give a slackness to the tillar rope on the one side, and allow of the force of the waves, when striking the rudder, to jerk the wheel; but there are positions for the fixed points and blocks, which have been determined by the aid of mathematical reasoning, that will give an equal tension on all portions of the tillar ropes, and in every position of the tillar.

Description of the diagram of a tillar thus fitted—a section of the head of the rudder; *a* being the centre of it and centre line of the pintles. *b* position of the blocks at the end of the tillar, to receive the ropes, the tillar *ab* being amidships, or being in the fore and aft direction of the ship. Divide the distance *ab* into three

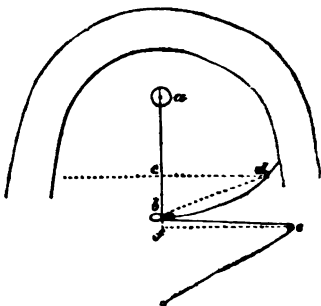

equal portions, of which *bc* is one, having previously swept the tillar down to describe the circle developed by the end of it. The point *c*, squared athwart the ship to meet the circle described by the end of the tillar at *d*, will give the position for the standing part of the rope; and the point *f*, set off $\frac{1}{2}$ of the length *ab*, or the length of the tillar from *b*, squared across the ship; and *fe*, taken as $1\frac{1}{4}$ of *cd*, will give the point for the station of the tillar block at the side of the ship. These points, thus practically determined, will ensure that the rope, roved through blocks placed at them, will move the tillar through the angle of 45° from the midship position on each side without any slack rope being caused by it. On this deck, at the extreme after end of it, the mess-place of the midshipmen, or what is termed the gun-room, is situated, formed by the after part of this deck being separated from the whole by a bulk-head or screen.

MAIN OR UPPER DECK.

This platform, on which the guns are not so heavy as those placed on the lower or gun deck, is termed by naval men the main deck, while by the shipwright it is called the upper deck. From the seamen it inherits this seeming contradiction in name from this deck having in former times been the place to which all the ropes were led for working the sails of the ship, and thence it became the scene of greater activity and the

main" point or centre of the evolutions of the ship. The ipwright calls it the upper deck, in consequence of its receiving a perfect upper line of battery, or that the guns on it range fore and aft of the ship, or through her whole length.

On this deck, in addition to the arrangements required for the efficient working and training of the guns, riding bitts have been placed in modern times for anchoring the ship; and on it all the requirements in the shape of bitts and sheaves are still fitted for working the sails as heretofore, though they are not generally used, except in bad weather. This platform at the after part is divided off into small rooms or cabins, each inclosing a gun, to form the sleeping berths of the ward-room officers of the ship; consisting of a commander, lieutenants, master, surgeon, purser, and marine officers. The centre part, between this row on each side of small bedrooms, is apportioned as a mess-room for these officers. This arrangement includes also a steward's room or pantry, and other requisites for ensuring the comforts of gentlemen who, under the most favourable circumstances, have not in their possession the most enviable berth under the service of the Crown.

QUARTER DECK, WAIST, AND FORECASTLE.

On the forecastle, or foremost part of this deck, the necessary mechanical expedients for bringing the anchor from the water when raised by means of the capstan (*vide* Appendix), to its surface are placed. Two horns, as they may be termed, are fixed one on either side of the ship outside, and are called cat-heads; each of these have sheaves or pulleys in their outer ends, and have a rope passed through them, and a block termed a cat-block to form a tackle or pulley; the block having a large hook worked as a part of the binding or holding of it, which hook is called a cat-hook; and this it is which is hooked into the ring of the anchor when it appears above the water and the anchor is thence, by the purchase or power which has been described, or what is called the cat-purchase, raised to the cat-head, and hangs suspended from the outer end of it;

in this position it is denominated as being at a cock-bill. To raise the lower end of the anchor, or technically to fish it, and stow the flues or spade-like arms of it against the side of the ship, an outrigger with tackles, called a fish-davit, is used; the anchor then usually lays with the shank to the sheer or longitudinal line of the side of the ship, and the pea of it, or the extreme point of the flue, rests on what is mechanically termed a bill-board. To keep the anchor in this position there are cat-head stoppers or lashings and shark painters or ties, and these have various ingenious contrivances for facilitating their being let go, when required for anchoring the ship; those usually fitted were invented by a Mr. Spencer of Chatham Yard, and are known in the service by the name of Spencer's slip-stoppers. Mr. Blake, lately master shipwright of Portsmouth Yard, has also a fitting or method for the same desirable end; but the nut-shell which this rudimentary work presents for the reception of even the mere technical terms adopted by the shipwrights, must and will be received as a just and sufficient reason for no details being given of these useful inventions. There are on the fore-castle holes through the bows of the ship, called fair leaders, for the ropes called sheets, connected with the head sails or those by which they are strained to the wind. Bolts are also placed round the masts to receive blocks for ropes to lead through from the respective yards and sails on the fore mast; and to the side of the ship immediately in the wake of the shrouds (or supports made of rope) to the lower masts, pin-racks, or pieces of wood with sheaves or pulleys in them to receive ropes and pins to which to belay those ropes, are bolted. In the waist, or between the fore and main masts, the heavy boats, called severally the launch and pinnaces of the ship, are stowed on what are termed the skid-beams; the deck of the fore-castle and quarter decks are stopped short at the waist amidships, which is thus left open; the passage to and from fore-castle to quarter deck being preserved by the deck at the sides of the ship going through and forming what are called the gangways.

The main mast has bitts round it and pin-racks similar to the fore mast. The cabin for the captain is on this deck, under another after deck, which is termed the poop. Guns are carried on the fore-castle and quarter deck, but not any to the waist or on the poop, except in the ships of modern construction, which have been armed with large guns to meet the steam warfare. On the outside of the ship, at the height of the poop-deck, long pieces of wood or of iron, named davits, are fixed for hoisting the boats, carried on the quarters, out of the water and securing them while at sea. Similar davits are fitted to the stern at the same height. On the stern also a life buoy on each quarter is fixed; means being furnished for letting it overboard immediately in the day-time, should a man fall into the water; and should a similar accident occur at night, the life buoy is so ingeniously contrived that a port-fire can first be fused or lighted, and then the buoy be let go, presenting by the light thus shown, a greater chance for the man to discover the buoy in a dark night, and for a boat from the ship to find both man and buoy, should he have been successful in reaching it. This description of buoy, which has for many years been fitted to all ships in the British Navy, was invented by Lieutenant Cook of that service, who must feel heartfelt gratification in having thus been the means of saving from a watery grave many a brother sailor.

On the rough treerails all round the ship, what is termed hammock netting (see sketch of Hammock Netting, p. 71), is placed for the reception of the hammocks or beds of the sailors, which are stowed or placed in them during the day for a two-fold purpose: one, of forming a protection for the men from the effects of the fire of the small arms of an enemy during an action; and the other to have a clear ship below during the day-time. The men in a line-of-battle ship usually sleep, or, as it is technically called, "hang up," on the lower deck, or the deck which carries the tier of guns nearest to the water; and the hammocks when brought up from below, and stowed in the hammock nettings, are protected from the rain and the sea by

painted canvas, termed hammock cloths. On the outside of the ship, arrangements are made for the rigging and sailing of her. The sketch below, marked Knee of the Head, shows the formation of the fore extreme of the vessel beyond the stem, giving the contour considered necessary for the appearance of the ship, and forming a base for the security of the bowsprit, by what is termed the gammoning; it also affords space for the arrangements required in the head of a vessel for a crew so numerous as that of a man-of-war. The figured dimensions on it are the sizes of bolts, in inches, driven in the knee of the head of a small man-of-war for fixing it. The channels, as outriggers to the shrouds or the supports to the lower masts, are the heaviest work. The breadth of them from the side is governed so that the shroud

Sketch of Knee of the Head.

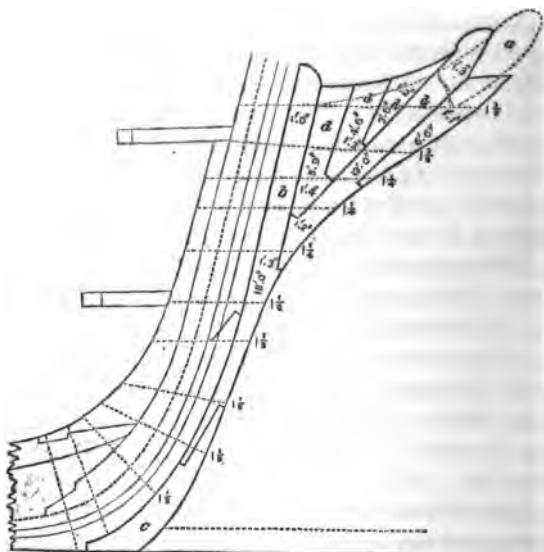

a, Figure head. *b*, Independent piece. *c*, Gripe. *d*, Chocks to fill up the knee.

or rope, when in place, may be 6 inches clear of the hammock rail (see sketch of Hammock Berthing.) The chain plates, as they are styled, are sometimes formed of links of iron. Bars of iron at other times form the communication from the rigging to the side of the ship. Great objections have been urged against the use of channels, as being subject from their exposed situation to be damaged by the force of the sea, and that of collision, should vessels run into each other; and plans have thence been put forward that in some cases have brought the direct strain from the masts to the upper side of the top side, to its manifest injury, and to the insecurity of the masts: while in others the channels have been formed by mere

Hammock Nettings.

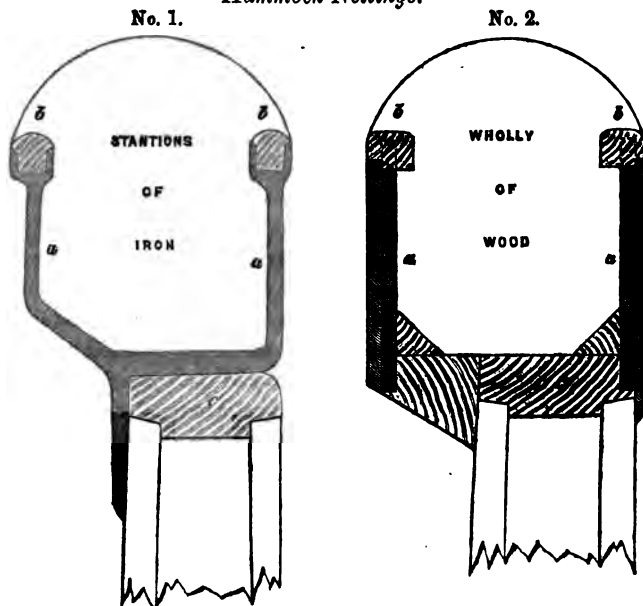

- No. 1.—(a) Hammock stantions of iron, with horns to receive the rails *b*.
 (b) Rails, 8 inches by 2½ inches, to form with berthing or board of ¾ inch thickness, boxes for and aft the ship for the hammocks. (c) Rough treerail.
 No. 2.—The same, made wholly of wood, with the same references.

bolsters worked on the side. The latter may be effective when used in ships where the breadth or width of them is unnecessarily great, and where great falling in of the sides has been the form given to the top sides of the vessel; and the removal of the channels from the sides of merchant ships may be desirable, from the convenience thereby afforded for their being placed in tiers or rows in a harbour, when lashed alongside of each other. At the bows, or fore part of the vessel, on each side, a wooden or iron outrigger, termed a boomkin, is placed to receive the lower end of the fore-sail, or what is called the fore-tack. There are also blocks or sheaves or pulleys let through the sides of the ship to admit the ropes which confine the ends of the sails, which ropes are technically termed "sheets;" thus there are fore and main sheets, boom sheets, &c. A ladder is also in these modern times fitted outside the ship, from the edge of the water to the gunwale at the entering port, which affords accommodation to visitors and the officers of the ship: in former times such things were considered unnecessary. The boom for the lower studding sail, or outrigger for that sail on the fore mast, is made to answer in harbour when the ship is at anchor as the security of the boats while afloat, and is not unaptly styled the guest warp boom, from the boats of visitors being secured to it while they are on board. There are numerous other minor fittings which are required to make perfect the hull and the requisites for the sails used for moving such a vast body as a ship of war; and the minutiae of them would, if given, be only intelligible to those whose paths are on the deep. A rudimentary work, as being the boat to the ship of science, is not intended or expected to carry the whole cargo of the ship at one trip, but this small work, although thus restricted, may nevertheless be productive of essential good, by giving to the youthful mind a bias towards the attainment of useful and practical knowledge upon the subject of naval architecture, involving as it does the welfare and stability of England as a Nation.

PART XIV.

Measurement of a Ship or Vessel by the old Rule for Tonnage.—Rule given in detail.—Remarks on the Causes of the Rule as being a faulty Approximation to the true Capacity of a Ship.—Rule practically applied to the Measurement of a Man-of-War.—Diagram showing the Method of applying the Rule.

Measurement of the Tonnage of a Ship, or a supposed approximation to her Capacity for carrying Cargo, by the old System of ascertaining what is termed the Builders' Tonnage of her.

THE general terms of this rule are these: that Burthen in tons = *Length of Keel for Tonnage* \times *Breadth for Tonnage* \times $\frac{1}{2}$ *Breadth for Tonnage*, divided by ninety-four.

These terms are determined on the draught of the ship, or taken off from the vessel when built, according to the following APPARENTLY arbitrary considerations:—

LENGTH OF THE KEEL FOR TONNAGE.

The capacity of a body is comprised under three dimensions; length, breadth, and depth. It would thence seem, that in forming a rule that was to ascertain the capacity of a ship for cargo, a length was taken that might fairly be considered to comprehend that portion of her which could be occupied by her lading, which length was called "Length between the perpendiculars for tonnage." This dimension by the rule is ordered to be taken as follows: The fore extreme to be at the fore side of the stem (*a*, sketch for Tonnage), at the height of the upper deck in two-decked ships of war, frigates, single-decked vessels, and merchant ships, and the middle deck of three-decked ships; and the after extreme to be at the back of the main post (*b*), at the height of the wing transom in square-sterned ships; and in ships with elliptical sterns, where the same height of the upper deck of two-deck ships, &c., or the middle deck of three-decked ships, cuts the line of the

counter; these points to be squared down to the line of the lower edge of the rabbet of the keel produced, and the distance between these intersections to be the "length between the perpendiculars for tonnage" (*cd*). This length, if taken as a measure of the length for capacity, would manifestly be doing so without regard to any contraction of the length in the lower part of the hold of the ship, which might arise from the rake given to the extremes, or that of the stem and stern post; but the rule, with a view to meet this consideration, diminishes the "length between the perpendiculars for tonnage"—first, for the rake of the stem, and, secondly, for the rake of stern post. The deduction to be made for the rake of stem is to be obtained by taking $\frac{3}{4}$ ths of the "breadth for tonnage;" while that for the rake of the stern post is to be the result which arises from allowing $2\frac{1}{4}$ inches for every foot that the upper side of the wing transom at the middle line, in *square-sterned* ships, is above the lower edge of the rabbet of the keel (*cd*), or the same ratio per foot in ships with elliptical sterns, for the height of the intersection of the counter line with the back of the main post above the same base; and the sum of these two estimated deductions is to be taken from the "length between the perpendiculars for tonnage," to give the "length of the keel for tonnage."

●
BREADTH FOR TONNAGE.

A dimension to be obtained by subtracting from the extreme breadth of the ship, at the height of the wales, the excess in thickness of the wales over the thickness of the plank of the bottom; thus a ship is in breadth from outside to outside of the wales 60 feet—the wales being 10 inches thick, and the bottom plank 5 inches; the excess of the wales in thickness over that of the bottom plank would in this example be 5 inches on each side; which gives 10 inches to be deducted from the extreme breadth of 60 feet for the "breadth for tonnage," so that the "breadth for tonnage" would be 50 feet 2 inches.

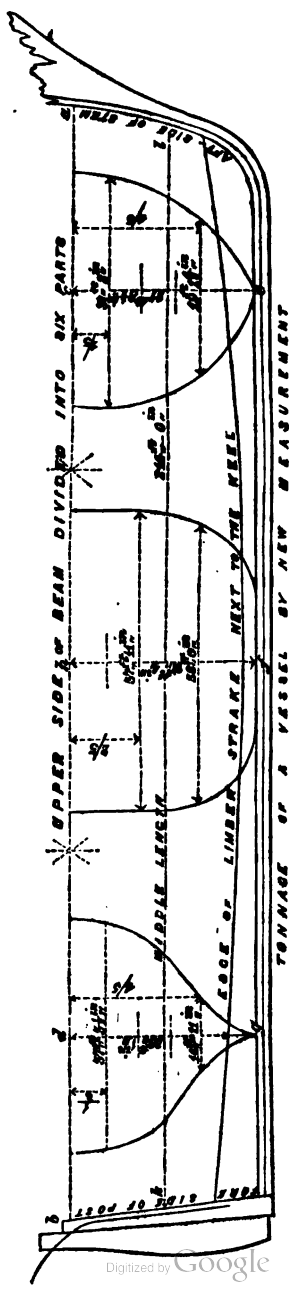
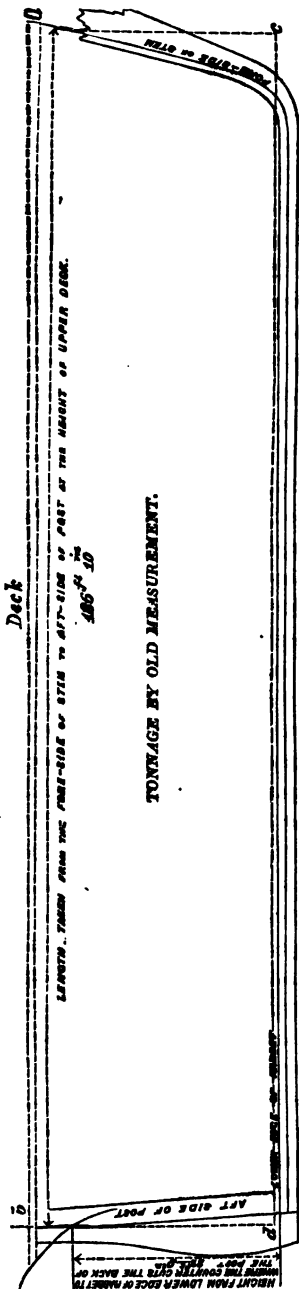

The "keel for tonnage" and "breadth for tonnage" of a ship having been thus estimated, the builder's tonnage of her as shown by the equation will be known, by multiplying the "keel for tonnage" by the "breadth for tonnage," and that product by "half breadth for tonnage"—the last product being divided by the number 94: the quotient thence arising will be the number of tons the ship was formerly registered as being able to carry. This rule, used as the test of the quantity of cargo that a vessel can carry, is absurd, one dimension which is so essential towards ascertaining the real capacity of her being left out in the calculation, viz., the depth; so that two ships having the same length and breadth, but the one being double the depth of the other, would nevertheless bear nearly the same nominal tonnage: in fact, the deeper ship would be the lesser one in tonnage, from the greater height of the wing transom (ab) in her above the lower edge of the rabbet of the keel, causing a larger deduction to be made for ascertaining her "keel for tonnage," giving thereby a less length for it and consequently for calculation; while it will be easily understood, that the double depth, all other things remaining the same, could not fail to give to the smaller registered tonnage vessel by rule, the power of carrying double cargo. It was this anomaly that tied the hands of the British merchant shipbuilder from making an effort towards any improvement in the forms of the mercantile navy of this country, and made the ships for commerce square and deep boxes with the ends rounded off for steerage: attempts have been made to dispel this bugbear to good properties in the ships forming the mercantile navy of this country; and, having given a practical example of this ancient method—for it is still perpetuated in the navy, where it is used as forming a standard of comparison only—another rule will be given, authorized by act of Parliament, by which it has been endeavoured, through the means of a series of internal measurements, to form an approximation to the cubical contents of the internal space or hold of a ship which it is intended should be occupied by the cargo or lading.

Example of the Old Measurement of Tonnage on a Vessel of the following Dimensions.

	Ft.	in.
“Length between the perpendiculars for tonnage,” or <i>a b</i> of fig.	180	10
Breadth, extreme, from outside to outside of wales	49	5½
Wales in thickness	0	8
Bottom plank in thickness	0	4½
Excess of the thickness of the wales over that of the bottom, 3½ inches, or both sides	0	7

From which the “breadth for tonnage” for using the rule will become as follows:—

Breadth from outside to outside, as above	Ft.	in.
Excess of wales over plank of bottom	49	5½
	0	7
“Breadth for tonnage”	48	10½

Whence, for rake of stem, ⅓ths of the “breadth for tonnage” equals ⅓ths of—

Ft.	in.
48	10½
×	3
5)146 8½	
29 4	

Which is the deduction that is to be made, according to the rule, from the “length between the perpendicular for tonnage” for the rake of the stem of the vessel.

The deduction to be made in feet and inches for the rake of the stern post will in this example be found, by the height of the wing transom above the lower edge of the rabbet of the keel, as (*d b*), being taken by measurement; and, supposing it to be 22 feet 9 inches, the ratio of 2½ inches for every foot of that height will give the sum to be subtracted—thus

Ft.	in.
22	9
×	2½ inches
inches 45 6	
11 4	

divided by 12)56 10 =

The deduction to be made from the “length between the perpendiculars for tonnage” for the rake of the stern post } = 4 8½

Whence, adding these two together, viz.—

	Ft.	in.
Deduction to be made for the rake of stem	29	4
Ditto ditto ditto post	4	8½
	34	0½

Will give the total reduction in feet and inches that must be made in the "length between the perpendiculars for tonnage" to obtain the "keel for tonnage" of the rule; or the "keel for tonnage" in this particular example will be found by taking from—

Ft.	in.	
186	10	Or "length between the perpendiculars for tonnage."
34	0½	= Deductions for rakes of stem and post as above.

Leaving 152 9½ for "keel for tonnage."

Whence burthen in tons =

$$\frac{\text{"Keel for tonnage"} \times \text{"breadth for tonnage"} \times \frac{1}{2} \text{"breadth for tonnage"}}{94}$$

$$\text{By substitution} = \frac{152 \text{ ft. } 9\frac{1}{2} \text{ in.} \times 48 \text{ ft. } 10\frac{1}{2} \text{ in.} \times \frac{48 \text{ } 10\frac{1}{2}}{2}}{94}$$

$$= \frac{152.76 \times 48.9 \times 24.45}{94} = 1942\frac{2}{3} \text{ tons.}$$

In schooners, cutters, and open-boats, the "length between the perpendiculars for tonnage" is taken, from where the line of the lower edge of the rabbet of the keel is intersected forward by the squaring down of the fore-side of stem at the bed of the bowsprit, and measuring the length from this point to where the lower edge of the rabbet of the keel, if produced, would cut the aft side of the main post; the deduction from this length for the length of tonnage being only that arising from taking ½ths of the "breadth for tonnage" for rake of stem; the rake of post being considered as accounted for by the above measurement; the rest of the rule the same as for other ships.

That the perpendiculars placed on the draught or drawing for a man-of-war may not be mistaken for the "length between the perpendiculars for tonnage," it is ordered that the former

shall be taken from the aft part of the rabbet of the stem to the fore part of the rabbet of the post at the height of the upper deck.

PART XV.

Measurement of a Ship or Vessel by the Rule for Tonnage, enacted by Acts of Parliament of the 5th and 6th years of the reign of William IV.—Rule given in detail.—Rule applied practically to the Measurement of a Vessel. Diagram showing the Method of Application.—Necessary Deductions to be made when the Vessel measured by the Rule is to be propelled by Steam.—Short Description of a more satisfactory Method of obtaining the real Tonnage or Burthen of a Ship, whether intended for War or Commerce.

THE tonnage by Act of Parliament, which, in practice, is designated New Tonnage, was formed to be an approximation to the internal capacity of the ship under the deck or the measurement of the hold in cubic feet of space, and thence to enable a determination of her tonnage to be made.

DEPTHS FOR TONNAGE.

Under this rule, it is enacted that the length of the upper deck, or of the upper part of the hold intended to be used for the stowage of goods, be measured at that height from the after part of the stem to the fore part of the stern post; and that such length be divided into six equal parts; and that at the foremost, middle, and aftermost points of division thus fixed, the depths from such points of division to the ceiling or internal planking at the inner edge of the limber strake, or the edge nearest to the middle line, be measured in feet and decimal parts of a foot: the dimensions thus taken are denoted "depths," and are shown on the fig. as *ce*, *hf*, *dg*. Should there be a break in the deck, or should the deck not be continued fore and aft the vessel, these depths are to be

measured from a line stretched along as a continuation of the deck.

BREADTHS FOR TONNAGE.

Divide the depths at each of the three stations, ce , hf , dg , thus selected, into five equal parts, and at these divisions of the depths measure the *breadths* of the internal form or inside of the ship on lines squared across the ship at the points or positions of the several depths that follow—

ce { Foremost station or division, when { at $\frac{1}{5}$ }
divided into fifths in the depth { and $\frac{4}{5}$ } from the upper deck ;

hf { Middle station or division, when { at $\frac{2}{5}$ }
divided into fifths in the depth { and $\frac{3}{5}$ } from the upper deck ;

dg { Aftermost station or division, when { at $\frac{4}{5}$ }
divided into fifths in the depth { and $\frac{1}{5}$ } from the upper deck ;

which measurements are defined on the sketch where the divisions are marked off and given in figured dimensions.

LENGTH FOR TONNAGE.

For the dimension to be used as length, it is enacted, that such length be taken at the height of the middle of the midship depth, on a line parallel with the upper deck, and in length from the after part of the stem to the fore part of the stern post (kl). These dimensions of depth, breadth, and length being thus taken, they are to be prepared for use by the following enacted regulations :—

DEPTHS.

To twice the depth at the midship division, hf , add the depths at the foremost, ce , and aftermost, dg , divisions— which call the sum of the depths.

BREADTHS.

Of those taken from the foremost section, ce , add together the breadths taken at the $\frac{1}{5}$ and $\frac{4}{5}$ divisions of the depth of that division.

Of those taken from the middle section, $h f$, add together three times the breadth at $\frac{2}{3}$, and once the breadth at the $\frac{1}{3}$ division of the depth of that division.

Of those taken from the aftermost section, $d g$, add together once the breadth at $\frac{1}{3}$ and twice the breadth at the $\frac{2}{3}$ division of the depth of that division.

The sum of these multiples of the breadths will give the sum of the breadths for tonnage.

The elements having been thus determined, the enacted rule may now be stated with a chance of its being understood, viz., that :

$$\text{Tonnage} = \frac{\text{sum of depths} \times \text{sum of breadths} \times \text{length for tonnage.}}{3500}$$

From a careful inspection of this rule, it will be found that the arbitrary character of the old rule is not wholly lost in the new, and that something yet remains to be done, to make the measurement of a ship for the burthen carried by her as just and certain as the meat weighed from the scales of the butcher : an example of this system is given, and then a method will be suggested which would seem to be not liable to serious errors, and easy of application.

References to the Diagram, p. 75.

- $a b$, Length at the upper side of beams, being taken from the aft side (a) of the stem to the fore side (b) of the stern post.
- $a c$, One of the divisions of that length, or $\frac{1}{5}$ of $a b$ from (a) on the aft side of stem.
- $b d$, One of the divisions of the length, as $a c$, or $\frac{1}{5}$ of $a b$ from (b) the fore side of the stern post.
- $c e$, The depth at the foremost division (c), measured from (c) to the point (e), considered well with the upper part of the limber strake at the edge next to the keelson and equal to 27.75 feet. This depth ($c e$) is divided into five equal divisions, and the breadths taken at the depth of $\frac{1}{5}$ and $\frac{4}{5}$, as marked on the fig. $\left\{ \begin{array}{l} \frac{1}{5} = 37.16 \text{ feet.} \\ \frac{4}{5} = 19.12 \text{ ,,} \end{array} \right.$
- $h f$, The midship depth measured — (as for $c e$) 27.4 feet, which is also divided into five equal parts, and the breadths taken at the $\frac{2}{5}$ and $\frac{3}{5}$ depths, as marked on the fig. $\left\{ \begin{array}{l} \frac{2}{5} = 37.9 \text{ feet.} \\ \frac{3}{5} = 28.0 \text{ ,,} \end{array} \right.$

d g, The depth at the aftermost division $d = 26.0$ feet, measured as for *cc* and *λ f*, divided into five equal parts, and the breadths taken at the $\frac{1}{5}$ and $\frac{4}{5}$ depths, as marked in the fig. $\left\{ \begin{array}{l} \frac{1}{5} = 37.27. \\ \frac{4}{5} = 14.90. \end{array} \right.$

λ l, The length taken through the middle division of the middle depth, being the length at that height from aft side of the stem to the fore side of the post, being on the fig. 214 ft. 0 in.

These dimensions will yield the following results by the rule:—

SUM OF THE DEPTHS.

	Feet.	Multiplier by rule.	Feet.
<i>d c</i> , Fore depth	$= 27.75$	$\times 1$	$= 27.75$
<i>λ f</i> , Midship ditto	$= 27.4$	$\times 2$	$= 54.80$
<i>d g</i> , After depth	$= 26.0$	$\times 1$	$= 26.00$
Sum of the depths			<u>108.55</u>

SUM OF THE BREADTHS.

	Feet.	Multiplier by rule.	Feet.
Fore division, <i>cc</i> , at $\frac{1}{5}$ depth. Breadth	$= 37.16$	$\times 1$	$= 37.16$
" " " $\frac{4}{5}$ " " "	$= 19.12$	$\times 1$	$= 19.12$
Middle division, <i>λ f</i> , at $\frac{3}{5}$ depth. Breadth	$= 37.9$	$\times 3$	$= 113.70$
" " " $\frac{1}{5}$ " " "	$= 28.0$	$\times 1$	$= 28.00$
After division, <i>d g</i> , at $\frac{1}{5}$ depth. Breadth	$= 37.27$	$\times 1$	$= 37.27$
" " " $\frac{4}{5}$ " " "	$= 14.90$	$\times 2$	$= 29.80$
Sum of the breadths by rule . . .			<u>265.05</u>

λ l, Length for the tonnage taken at the height of the middle division of the midship depth $= 214$ ft. 0 in.

Whence, in this example,—

$$\begin{aligned} \text{Tonnage} &= \frac{\text{sum of the depths} \times \text{sum of the breadths} \times \text{length for tonnage}}{3500} \\ &= \frac{108.55 \times 265.05 \times 214.0}{3500} = 1759.531 \text{ tons.} \end{aligned}$$

In applying this rule to steam vessels—the same method is to be pursued, and a deduction to be made from the result

for the cubical contents of the engine room, which contents are to be estimated as follows:—Measure the inside length of the engine room in feet, and decimal parts of a foot, from the fore to the after bulk head of such engine room—then multiply the said length by the depth of the ship at the mid-ship division, *h f*, as aforesaid, and that product by the inside breadth at the same division, *h f*, taken at $\frac{2}{3}$ of the depth from the deck, or as before taken, 87·9 feet; this product divided by 92·4 will give a quotient that is to be considered the tonnage due to the cubical contents of the engine room, and further, the amount to be deducted from the calculated tonnage by the rule; and by the same Act of Parliament it is further enacted, that the tonnage of all ships or vessels, whether belonging to the United Kingdom or otherwise, if there shall be occasion to measure them while their cargoes are on board, shall be computed by the following rule and dimensions:—

1st. The length on the upper deck between the after part of the stem and the fore part of the stern post.

2ndly. The inside breadth on the under side of the upper deck at the middle point of the foregoing length.

3rdly. The depth from the under side of the upper deck, down the pump well to the limber strakes or internal plank.

With these three dimensions ascertained, the Act directs that the product of the three, viz., length multiplied by breadth, and their product by the depth, shall give a result which, being divided by 180, the quotient shall be considered as an approximation to the true register tonnage of the ship, or her capacity for carrying stores and cargo.

The most effectual method to ascertain the tonnage of ships employed in the merchant service would be, that the draught of water of the vessel when she is fully equipped and stored for sea, but without cargo in her, should be taken and registered by the officers of the customs, such draught of water being also cut in on one of the main beams of the vessel in a manner similar to that now required for the tonnage; and in

all vessels built in England, a scale of displacement formed as described in the Elementary Rudiments of Construction should be cut in on the same beam of the ship—when the difference between the displacements, given per scale, by the mean draught of water of the ship when light and that when loaded (be it what it may), will be the actual amount of tonnage or burthen the vessel has carried.

In foreign vessels, over which the government of this country has no control, and can thence not enforce a similar proceeding for them while building, let the draught of water be carefully taken in the English port in which they intend to discharge their cargoes, previously to their breaking bulk, and let it also be taken after the ship has been fully discharged of her burthen: the difference between the mean draughts of water of these two immersions, or those arising from adding (in each case) the draught of water forward to that aft, and taking the half thereof, will give the rising of the vessel bodily in the water in feet and inches; and it is not difficult at half way of that emersion to calculate from the ship the area of the level section of her, and equally easy to find the capacity due to an inch of immersion at that line. As this latter would form the average capacity of the vessel to an inch immersion, the whole lading or weight would be tolerably accurately given by reducing into inches the difference shown in feet and inches between the mean draught of water when loaded and that when the cargo is discharged, and multiplying the result by the capacity per inch before determined. The task is within the attainments of a man of ordinary abilities, and could be accomplished in a much shorter period of time than a first judgment of such a proceeding would surmise; and as these ships are usually employed between the same ports, once done, the operation would not require to be repeated.

PART XVI.

Mechanical Power used for Launching.—Declivities of Slip and of the Blocks the Vessel is built on.—Sliding ways.—Bilgeways.—Inclination of Sliding ways.—Upper side of Sliding ways, whether straight or cambered.—Ribbands.—Method used by the French in Launching.—Method described of putting the Bilgeways on the Sliding ways.—Stopping-up Pieces.—Poppets.—Cleats on the Bottom.—Dagger Planks.—Paying with Tallow Bilgeways and Sliding ways.—Setting up the Ship.—Removing the Building Blocks.—Christening.—Dog-shore.—Launch of the Ship.

THE LAUNCH OF THE SHIP.*

THE ship having been completed on the building slip, the next step is to place her in the water, which apparently Herculean task is accomplished in Her Majesty's naval arsenals by a method of which the following is an outline.

The mechanical power designated the "inclined plane" has been made available to the moving into the water such a vast fabric as the first-rate man-of-war whose armament is to be 120 guns and the hull of which weighs at the least 2600 tons. The slipway (*a*) on which the vessel is built is to this end an inclined plane, and the upper surface of the blocks on which the ship rests while building and which received the keel, the first assemblage of timber used in her practical construction, is made to partake of the same property; by which means the ship, while under practical construction, lays inclined to the horizon at an inclination of $\frac{1}{4}$ ths of an inch to a foot in her length, or at nearly that of 1 foot in 19 feet below the horizontal plane marked *b*, in the Plate of the Launch.

The weight of the ship has to be transferred from these blocks to a cradle or support for moving her down two narrow inclined planes, one on either side of the keel of the ship. These narrow planes are denominated the sliding ways, and they

* The letters in italics, of the text, bear reference to the Plate of the Launch.

are so placed on the slip that the outside of the bilgeways, or the foundation of the cradle which supports the ship while launching, shall be $\frac{1}{4}$ th of the main or greatest breadth of the vessel from the side of the keel, which will give the bilgeways a spread, from the outside of the one to the outside of the other, of $\frac{1}{3}$ rd of the main breadth of the ship, and the breadth of the keel in addition. The bilgeways is a technical term given to a long assemblage of timber, combined to form the basis of the cradle in which the ship rests when launching. The sliding ways may justly be termed the rails or trams to receive the bilgeways and cradle, which latter may be said to form the carriage or truck to carry the ship into the water. The sliding ways are composed of blocks of wood laid to a determined height to receive planks of 3 inches in thickness and 10 inches in width, forming on the upper surface inclined planes of about 3 feet 4 inches in width, *d* of Plate. These planks are usually laid on the blocks with close joints; but experience and reflection point out that their being kept an inch apart is more efficient, practice having taught the lesson that powerful adhesion takes place by reason of the exclusion of the atmospheric air from the surfaces in contact; viz., those formed by the upper sides of the sliding ways and the under sides of bilgeways, and these being too perfectly in contact, an adhesion has to be overcome, which requires great force to be used in starting the ship, whereby delay is sometimes caused in launching.

The bilgeways should be in length at least $\frac{2}{3}$ ths that of the ship, or, for a first-rate of 120 guns and 205 feet in length, the bilgeways should be 170 feet, their breadth and depth being about 2 feet 6 inches square. The breadth of the bilgeways will determine that of the sliding ways, and also the position of them, regard being had to the limit before given, for the extreme spread of the bilgeways; the sliding ways are then to be allowed sufficiently wide beyond the outside of the bilgeways, to receive a square piece of fir of about 5 inches, termed a ribband, which is secured to the sliding ways

to prevent the bilgeways from being forced outwards by the weight of the ship while launching. The foremost piece of ribband on each side is of oak, as it becomes the abutment of the after end of a piece of timber which is called the dog shore, *g* of Plate, the fore end of which butts or stops against large cleats, *r* of Plate, on the bilgeways, forming a preventative against the bilgeways (*s*), slipping down the sliding ways (*d*), and constituting the means by which the ship is retained on them (*d*) until the time has arrived for launching her. The foremost pieces of ribbands, the better to enable them to resist the strain brought on them, are bolted and dowelled to the sliding ways; and to prevent the bilgeways from being forced inwards, shores (*s*) are placed on cleats from the sides of the keel to the insides of them. The inclination to be given to the sliding ways is governed by the size of the ship, and the rise and fall of the tide; to which considerations may be added the inclination of the slip on which the ship is built. In the Queen's service the slips are nearly all built at the same inclination to the horizon.

The smaller vessels require the most inclination to be given to the sliding ways, and on some occasions they have had as much given to them as $1\frac{1}{2}$ inches to a foot, to afford an impetus to their comparatively light weight of hull; the larger ships, from first-rates to frigates, have usually from $\frac{3}{4}$ ths to $\frac{7}{8}$ ths of an inch in a foot declivity, and it has been found in practice that the inclination of $\frac{3}{4}$ ths of an inch has given to the vessel the velocity necessary for safety and efficiency.

It was formerly the practice in Her Majesty's service for the upper side of the sliding ways to be formed in their length to an arc of a large circle, which was technically termed cambering the ways. This method has been considered in modern times objectionable, as tending, it is said, to break the vessel, or to alter her form lengthways; this objection will not hold good if the ways are the arc of a large circle for their whole length; but if it is only such from the after end of the bilgeways before the vessel moves, the cambering

would be detrimental to the vessel, as the bilgeways would then alter their form from the straight line to the arc, which would thence allow of that change of longitudinal form in the ship which is denoted breaking.

The advantage that is said to arise from cambering the sliding ways is founded on the following consideration :—that should the groundways not be firm, the weight of the ship, when the upper surface of the ways is laid straight, would force it into a concave one, which would be detrimental to her starting; in the case of the ways being cambered, the form of them being thence that of an arch, the upper surface of them would be better preserved.

The French launch their ships-of-war on their keels, having side bilgeways merely to steady the ship; the stability of the groundways must be the main source, in both systems, of keeping the forms of the ships unaltered in launching. In the method used in the English naval arsenals, care must be taken to ensure that the fore foot of the ship launches clear of the slip, which will always be the result if the declivity given to the sliding ways be less than that of the slip; should the contrary be the case, the height of the foremost block on which the vessel was built, the length of the slip, and the proposed declivity, must be considered, to prevent the fore foot of the vessel from striking the groundways of the slip at the lower end of it. The slide beyond the slip is laid during the recess of the tide, either on piles driven for that purpose, or on permanent groundways.

The bilgeways having been hauled up on the sliding ways and placed under the bottom of the ship, in their position, as before described, of $\frac{1}{3}$ th of the main or principal breadth of the vessel from the keel, large pieces of fir, called stopping-up pieces, are placed on the bilgeways in the middle part of them to meet the bottom of the ship; but at the fore and after parts, where the form of the vessel, from its sharpness, would cause these pieces of fir, if continued, to be very bulky pieces of timber, timbers are placed like shores from the

upper side of the bilgeways to the bottom of the ship. These timbers are called poppets (*k* of the Plate), and are usually formed of square fir timber termed baulk; the heads of them are prevented from flying off the bottom of the ship by their being confined to it by the lower edge of a plank bolted to the bottom of the ship; this plank having likewise cleats (*n'n'*) screwed to the bottom of the vessel, to support the upper edge of it. The lower ends or heels of the poppets rest on a plank called a sole piece (*ll*), which is placed on the upper side of the bilgeways; the sole piece having a groove taken out of the centre of it to receive tenons raised in the heels of the poppets. The poppets are usually their dimensions apart. The whole of the after poppets, except the extreme after three, and all of those forward, except the extreme forward ones, are placed plumb, or square to the horizon. The foremost three poppets are placed with the heels of them forward, to make them stand as shores against the heads of the other fore poppets, when the ship's bows in launching are pressed to the sliding ways by reason of the excess of buoyancy of the after body of the vessel.

These poppets are united to the stopping-up which is worked on the midship portion of the launching cradle by planks, which are denominated dagger planks. The ribbands (*g*), which are placed on the sliding ways to confine the bilgeways on them, have greater spread or space given between them than that given to the bilgeways themselves. This excess of space is termed "play," and is usually $\frac{3}{4}$ of an inch at the fore end of the bilgeways, and 1 inch at the after end of them on each side, spread out at the extreme end of the slide to $2\frac{1}{4}$ inches. The bilgeways are usually what is termed "turned out" the day before it is proposed to launch the ship, which means that the poppets are taken down and the stopping pieces taken out of their places, and the bilgeways turned over outwards, leaving their under sides to face the keel of the ship. The upper sides of the sliding ways, to the length of the bilgeways, and the under sides of the bilgeways themselves, are then payed over with melted

tallow, to which, when cool, soft soap is sometimes added in patches; others use oil in preference. The bilgeways are next "turned in;" the cradle, composed of stopping pieces and poppets, is restored; and the whole, on the morning of the launch, is set to the bottom of the ship, as, between the upper surface of the bilgeways and the lower surfaces of the stopping up and the sole pieces placed to receive the heels of the poppets, large wedges called slices (*o o*) are placed inside and outside of the bilgeways, and men with mauls or large hammers are stationed to these wedges. By their united and simultaneous efforts, the slices raise the ponderous mass in the cradle, or at least take the weight of the ship from the blocks on which the after part of the vessel rested while building; these blocks under such a process become loose or slack, and are removed from under the ship as the tide rises. The fore part of the cradle is not set to the bottom of the ship so firmly, and the weight of the ship rests in part on the foremost building blocks, which are split out from under the ship consecutively, so that shortly before the hour of launching, or high water, the mighty fabric may be seen from aft resting on the sliding ways, suspended, as it were, in the air, on two comparatively narrow ribbands, and man's ingenuity and skilful perseverance seem triumphant. At this stage of the exciting scene, the vessel is christened by wine being thrown against the bows, or fore part of her, and her name given to her, after which the word is given to "down dog shore," and the ship, the fruits of years of labour and anxiety, freed from the last fetter that binds her to the stable earth, passes into the element in which she is destined to bear the battle's bront and the merciless peltings of the howling tempest.

References to the Plate of the Launch, as descriptive of the foregoing text.

- a Groundways of the slip, which, in Her Majesty's arsenals, is laid at the declivity of $1\frac{1}{4}$ inch in a foot.
- b Ticked line denoting the upper surface of the blocks on which the keel of the ship rests while she is building.

- c* Section of the building blocks. The inclination of these blocks from the horizon is 1 foot in 19 feet.
- d* Section of the sliding ways as composed of blocks and planks.
- e* Section of the bilgeways laid on the sliding ways, the outside of the one bilgeway being apart from the outside of the other $\frac{1}{2}$ the main or greatest breadth of the ship, together with the breadth of the main keel.
- f* Section of the bilgeways lengthways.
- g* Ribbands, or square pieces of fir, secured to the sliding ways to prevent the bilgeways from spreading or being forced out when the ship is launching.
- h h* Inclination given to the sliding ways, being usually from $\frac{3}{4}$ to $\frac{1}{2}$ of an inch to a foot.
- i i* Stopping-up amidships, composed of large pieces of fir.
- k k* Poppets or shores before and abaft the stopping-up pieces.
- l l* Sole-pieces or planks worked to receive the lower ends or heels of the poppets (*k k*).
- m m* Dagger planks to connect the poppets (*k k*) with each other, and unite them with the stopping up (*i i*).
- n n* Planks worked to the bottom of the ship, to confine the upper ends or heads of the poppets (*k k*).
- n' n'* Cleats to support the plank (*n n*). They are screwed to the bottom.
- o o* Slices or large wedges placed between the sole-pieces, stopping-up and bilgeways, to set the launch to the bottom of the ship, and take the weight of the vessel off the building blocks (*c*).
- p* Ribband shores to support the ribbands and prevent them from spreading.
- q* Dog shore, with its heel resting against the fore end of the foremost length of ribband, and its head against the launching cleat (*r*) on the bilgeways.
- r* Launching cleat to receive the fore end of the dog shore (*q*). The under side of this cleat (*r*) should be kept above the upper side of the ribbands (*g*), as in launching the cleat (*r*) should pass over them.
- s* Shores placed inside the bilgeways, from the ship to the bilgeways, to prevent them from tripping inwards.
- t* Trigger placed under the dog shore, and removed immediately previous to the launch of the vessel.
- v* Holes in the ends of the bilgeways, to receive ropes which are led on board the ship, to secure the bilgeways when the vessel is in the water, as the bilgeways then usually float up from under her.

PART XVII.

Docks—how situated.—Entrance—how closed.—Gates or Caissoon.—Vessel's Position on the Blocks.—Guys or Ropes—their Use.—Shores, Breast—their Use.—Vessel Upright or Plumb.—Method of determining it.—Diagonal Shores—their Position.—Bilge Shores.—Blocks—their Form.—Method of removing the Angular Blocks for False Keel.—Copper Sheathing—when removed.—Places usually defective pointed out.—Defects should be rigidly searched for previously to the Commencement of Repairs.—Advantages arising from such a Course of procedure.—Inside and Outside Planking—when and where to be removed.—Beams and Iron Knees to be well examined.—Rudder to be unhung.—Pintle and Braces to be overhauled.—A Plate of a Dock with Reference to these Remarks subjoined.—References to Plate 3.

DOCKS OF THE ARSENAL, USUALLY TERMED WET DOCKS.

THE repairs of the ships of Her Majesty's navy and those employed for commercial purposes are mostly performed in what is termed a wet dock, being an excavation lined with wood or stone, made contiguous to the water, and having an entrance opening into the river or harbour: the flat or lower part of the excavation or of the dock, in Her Majesty's dock-yards, is usually laid either level, or the after part to be deeper than the fore part, from 12 to 14 inches, and it is below low-water mark, to give a greater depth of water in them, when the vessel has been floated at high water into the dock, in the which blocks have been laid to receive her, similar in other respects, but not inclined, to those on which a ship is built on a slip; the entrance to the dock is closed by gates, or by what is termed a caisson*, and the water at the falling of the tide is let out of the dock through large drains called culverts.

The vessel is placed with her keel immediately over the centre of the blocks, in most instances laid in the middle of the dock, and kept in that position by ropes, technically termed guys, two of such being made fast to each bow, or on either side of the head, and two to each quarter, or on either side of the stern; they are distinguished as being starboard and port, bow

* The caisson is a floating gate.

and quarter guys. For the more effectual using of these guys, old guns or wooden stumps called bollards (*a*, Plate of Dock) are placed at intervals round both sides of the dock, and at a short distance from it. These form posts round which the guys can be wrapped to check the ship when she is being hauled into or out of the dock, and when the dock is unoccupied ropes or chains placed from the one to the other all round it, form a preventive to accidents.

Before the ship, by the falling of the water, takes the blocks, shores or long pieces of timber are prepared, of such lengths as to reach from the sides of the dock to those of the ship; and these shores are hung up to the vessel by ropes to the required positions. In the man-of-war their stations are governed by the port timbers, at the height of the deck or beam-ends, as forming the best security or abutment to them. This tier of shores is called the breast shores (*A*, Plate). But it should be ascertained before grounding, by the means of a plumb line (*f*), whether the ship is upright: should she not be so, the vessel is trimmed by weights on board of her; but if there be none available, the breast-shores, when the ship is firmly grounded on the blocks, are set the more vigorously on the side which is inclined to, until the vessel is brought to the vertical position; the heads of these shores, or the ends of them, against the sides of the ship should be the highest, that they may not tend to depress her when floated again after the repairs are completed. Before the breast-shores are set to the ship she is allowed to settle well on the blocks, or the water to drop from her at least 18 inches, that her weight may in part be on them; when, wedges being placed behind the heels of the shores or at the ends of them, which are against the sides of the dock, a man to each shore drives simultaneously on the wedges on both sides of the dock, and she is then secure. As the water further falls, shores, denoted diagonals (*B*, Plate), are placed lower down and between the breast-shores, and in large ships a second tier of these shores is considered necessary, placed below the 1st diagonals (*c*,

Plate); under the breast-shores, when the water is quite out of the dock, which is effected by pumps where the flat of the dock is below the fall of the tide, shores called bilge-shores (*d*, Plate) are placed, and in a large ship having two sets of diagonal shores they will come under the 1st diagonals (*b*, of Plate).

It should have been said, that before the water is let into the dock, the blocks are examined and well lashed down, and the fore and after ones required to receive her length of keel are marked in position on the upper side of the dock. The bob and mouse lines should also be proved (*f*, Plate). These lines are to point out the centre of the blocks; they are formed like a bricklayer's plumb, the plummet (*b*) being held over that centre by lines going across the dock, and the sides of the dock give parallel lines to take them fore and aft upon. The line thus fitted, termed the bob, precedes the ship, and that denoted the mouse follows her; the two thus used in conjunction will ensure the vessel being placed immediately over the centre of the blocks.

Angular Docking Blocks.

- a* Iron wedges.
- b* Wooden cap, plated with iron on the under side.
- c* Block, plated with iron on the upper side.

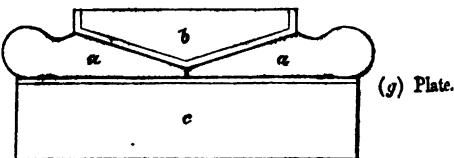

The blocks fitted in this manner are denoted Sir R. Seping's angular docking blocks, having been introduced into Her Majesty's service by that officer.

Battering Ram.

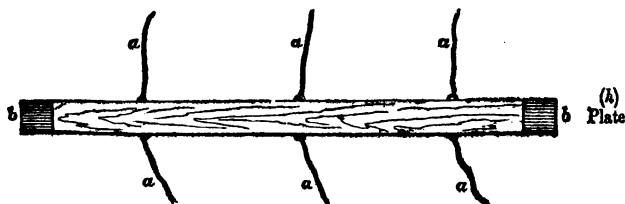

The battering-ram is used to remove the angular blocks when the ship is setting on them, should such be required during the repairs, or for removing the false keel, or caulking the garboard or lower seam of planking (see sketch of Blocks), the ropes *a* enabling men to give a powerful blow on the sides of the wedges *a* to free them: the ends *b* of the rams are armed with iron caps.

In the royal dockyards these angular blocks that the ship rests on while in the wet dock are formed of angular blocks of iron and wooden blocks iron-plated on their surfaces (see sketch, *g* Plate, p. 94). The advantage that arises from the use of these blocks consists in their being easily removed locally from under the ship, their wedge-like form allowing them to be taken from under the vessel in a very short time; and by these means the false keel of a ship may be shifted without the weight of the ship having been taken by shores. These blocks, when restored under the keel, are rammed up by the heavy logs of wood armed with iron at their ends, called battering rams (see sketch, *h* Plate, p. 94), and are thence made again to bear their portion of the weight of the ship. The ship having been placed in the dock and secured by the shores, as before described, if the repairs required are known to be extensive, the copper sheathing is taken off the bottom of her, and planks are split out all fore and aft, in those parts of the ship that past experience has pointed out to be the most likely for decay to arise: such has been found to be the case in the outside planking between wind and water, or more immediately in the vicinity of her line of floatation (*o*); and in the turn of the bilge the timbers of the frame are very subject to rot, from the wood being cut across the grain and the heart of it being thus exposed to wet. In the outside planking above water, the plank immediately in the wake of the channels will often be found defective, from the strain brought on it by the shrouds causing the plank to open, or the topsides of the ship to work; while the timbers and planking in the immediate neighbourhood

of the hawse-holes, from being more subject to wet, are also places that require to be well overhauled. c and B (*vide* Plate of Dock), the waterways and beam ends, are the most exposed to the effects of water by leakage, a fruitful source of decay; but to prevent disappointment and unnecessary outlay in the repairs, the ship should be thoroughly opened. All defects should be removed before any new work, or a restoration of her form, is allowed to take place, as most serious expenses have been incurred, nay, ships of war have been repaired that would have been taken to pieces, had the defects of the ship been fully laid open in all parts before the first discovered defects had been made good; and it evidences a sound judgment in directing the repairs of a ship when a thorough search for defects and the total removal of them before any new materials are provided, much less worked into the ship, is the course pursued. This method of proceeding presents another advantage—that by the timbers of the ship being thrown open to the air for a longer time, a check will be given to any incipient seeds of decay, or to the production of fungus. When the repairs to be executed run to a great extent, more especially in the frame of the ship, it becomes a matter of serious consideration whether it would not be more advantageous to break the vessel up, using the serviceable portions of her (which will generally be found to be the beams, and the lower timbers of the frame) in the construction of another vessel; should it, however, be deemed advisable still to continue the repairs, the most effective and economical proceeding would be, to take off the topsides outside, as low down as the wales, and remove the interior planking up to the same line: this method enables the shipwright to have a full inspection of three sides of each timber; allows the defective timbers to be easily removed, and the new ones to be replaced with facility; and the planking that is retained outside and inside, serves as an effectual ribband to preserve the form of the ship. The ends of the beams of the several decks should be examined, by their being bored

with an auger or large gimlet from the side of each in a slanting direction, into the beam-end, but if the outside planking requires to be taken off in the wake of the beam-ends, an efficient external survey of them can be made without recourse being had to the internal one: care should be taken in large repairs that the form of the ship be preserved by means of harpins, ribbands, and shores, where required, similar to those described for ships in building. But it should be with great caution that large repairs are undertaken, the expense attendant on them being more than would arise from building a new ship, from the combination of the two operations of pulling to pieces and putting together again. The knees to the beams of the several decks should be well examined, and any appearance of working—which would be evidenced by the bolt heads being drawn down—should be carefully considered, and an endeavour made to remedy the defect, as the working of the ship on her fastenings is attended with a twofold evil—the one that of rapidly weakening the fabric; and the other, by the assistance of wet, of producing with equal speed the working shipwright's friend—rot, and its consequence—the necessity of extensive repair.

The rudder should be unhung after the woodlock is removed, and the pintles and braces by which it is hung should be carefully examined. The head of the rudder should be well inspected to ascertain if the wooden portion of it has been strained, and that the iron hoops on it are firmly in their places. Too much precaution cannot be used to ensure the efficiency of the rudder, as the lives of the crew and the safety of the ship depend on the perfect order and strength of it.

A sketch of one of the largest wet docks in H. M. dockyards is subjoined, with reference to the remarks that have been made on this subject. In addition to the wet docks that have been described, fitted with gates or caissons to exclude the water, there are in some of H. M. dockyards small open

docks, called graving docks, which admit of a vessel being placed in them and grounded; the fall of the tide leaving the bottom of the ship dry, and allowing any slight defect to be made good before the tide again rises. They were originally constructed for breaming or firing the bottoms of small vessels before the introduction of copper sheathing, when their external planking became foul with weeds; these were always inconvenient for use, and the work being necessarily performed in them under great haste, and thence not efficiently done, they have fallen into disuse.

A DESCRIPTION OF PLATE 3.

Section showing the Timbers of the Frame, and the Positions of the Outside and Inside Planking of a Merchant Ship, with a Reference to the several Parts, giving the Technical Term for each Portion of the delineated Section of the Ship.

- | | | |
|---|---|-------------------|
| <ul style="list-style-type: none"> a Half section of the keel. bb False keel. ee Garboard strakes of outside planking. ef Plank of the bottom. fg Diminishing plank. hg Wales. z Black strakes. xy Sheer strakes. w Rough tree rail. v Waterway to quarterdeck. t Shelf to ditto. s Clamps. q Upper deck spirketting. p Upper deck waterway. o Upper deck shelf. n Upper deck clamps. m Lower deck spirketting. l Lower deck waterway. k Lower deck shelf. i Lower deck clamps. | } | Outside planking. |
|---|---|-------------------|
- L L, L, L Thick strakes worked over the heads of the 3rd, 2nd, and 1st futtocks and floors.

200, 201, 202 Spaces between the thick strakes.

c Side keelsons.

d Main keelson.

k Head of the fillings of wood, placed in between the timbers as described in the text, under the head of fillings between frame timbers.

The elevation on this plate shows the position of the ports and the trussing between them. The practical carpentry of the ships for commerce, built by Messrs. Smith, of Newcastle, and the firms of Wigram and Green, of Blackwall, of which this section of a merchant vessel may be said to be an outline, bears so close an affinity to the work that has been described as the practice of the Queen's service, that the explanation for the one will answer equally well for the other.

PART XVIII.

Principal dimensions of the several rates of Ships in Her Majesty's Navy.—
Armaments.—Weight of Anchors.—Weight of Cables.—Masts and Yards
—Weight of the Ship.—Weight of the Hull of the Ship.—Weight of the
Material received on Board.

FIRST RATE. 120 guns. Tonnage, 2609 tons.

Complement of Men and Officers, 1000 in number.

PRINCIPAL DIMENSIONS.

	Ft.	in.
Length on the gun deck	205	0
Length of the keel for tonnage	170	7
Breadth, extreme	53	4
Depth in hold	24	0

ARMAMENT.

	No. of guns.	Weight of each.	Length.	
			Cwts.	Ft. in.
Lower deck	32	4 of 8 in.	65	9 0
		28 32 pdrs.	56	9 6
Middle deck	34	2 of 8 in.	65	9 0
		32 32 pdrs.	50	9 0
Main deck	34	32 pdrs.	41	8 0
Quarter deck and forecastle	20	6 32 pdrs.	45	8 6
		14 32 pdrs. carrds.	17	—
Total weight of the guns				273 tons.
Weight of the broadside in lbs.				2028 lbs.

F 2

Weight of the principal anchors (4 in No.) .	Weight of each.		Total weight.	
	Tons.	cwts. qrs.	Tons.	cwts. qrs.
	4	19 0	19	16 0

WEIGHT OF THE PRINCIPAL CABLES.

	Weight of each.			Total weight.		
	Cwts.	qrs.	lbs.	Tons.	cwts.	qrs.
3 hempen, of 25 inches circumference .	116	2	20	17	10	0
4 chain, of 2½ inches diameter of link .	248	0	0	48	12	0
				66	2	0
Weight of the anchors				19	16	0
Total weight of the principal cables and anchors				85	18	0

MASTS AND YARDS.

		Length.		Diameter.	Weight.		
		Feet.	Inches.		Tons.	cwts.	qrs.
Lower Masts	Main	82	... 40	... 20	2	0	
	Fore	74	... 37	... 15	18	0	
	Mizen	59	... 26	... 5	8	0	
Lower Yards	Bowsprit	51	... 40	... 12	0	0	
	Main	105	... 25	... 5	3	0	
	Fore	91	... 22	... 3	16	0	
	Mizen, or cross-jack	71	... 17	... 1	8	0	
Total weight of the masts and yards				63	15	0	

Total weight of the ship, with stores and equipments, to a draught of water of	Afore	Ft.	in.	Tons.
	Aft	24	7	
Weight of the hull, to a draught of water of .	Afore	15	10	2462
	Aft	18	6	
Weight of the material received on board				2208

SECOND RATE. 84 guns. Tonnage, 2284 tons.

Complement of Men and Officers, 750 in number.

PRINCIPAL DIMENSIONS.

	Ft.	in.
Length on the gun deck	196	5½
Length of the keel for tonnage	162	3½
Breadth, extreme	51	5½
Depth in hold	22	6

ARMAMENT.

	No. of guns.	Weight of each.		Length.	
		Cwts.	qrs.	Ft.	in.
Lower deck	30	6 of 8 in.	65	...	9 0
		24 32 pdrs.	56	...	9 6
Main deck	32	2 of 8 in.	65	...	9 0
		30 32 pdrs.	48	...	8 0
Quarter deck and forecastle	22	6 32 pdrs.	41	...	8 0
		16 32 pdrs. carads.	17	...	—
Total weight of the guns					203 tons.
Weight of the broadside in lbs.					1488 lbs.

Weight of the principal anchors (4 in No.)	Weight of each.		Total weight.	
	Tons.	cwts. qrs.	Tons.	cwts. qrs.
4	5	0	17	0 0

WEIGHT OF THE PRINCIPAL CABLES.

	Weight of each.			Total weight.		
	Cwts.	qrs.	lbs.	Tons.	cwts.	qrs.
3 hempen, of 23½ inches circumference	102	3	12	15	8	2
4 chain, of 2½ inches diameter of link	216	0	3	43	4	0
				58	12	2
Weight of the anchors				17	0	0
Total weight of the principal anchors and cables				75	12	2

MASTS AND YARDS.

		Length.		Diameter.		Weight.	
		Feet.	in.	Inches.	Tons.	cwts.	qrs.
Lower Masts	Main	86	3	40	20	0	0
	Fore	79	3	37	15	12	0
	Mizen	63	2	26	5	6	0
	Bowsprit	51	0	40	12	0	0
Lower Yards	Main	105	0	25	5	3	0
	Fore	91	0	22	3	16	0
	Mizen, or cross-jack	71	0	17	1	8	0
Total weight of the masts and yards					63	5	0

Total weight of the ship, with stores and equipments, to a draught of water		Ft.		Tons.	
		in.			
	Afore	23	0	3721	
	Aft	24	9		
Weight of the hull to a draught of water	Afore	14	3	1959	
	Aft	18	9		
Weight of the material received on board					1762

THIRD RATE. 72 to 76 guns. Tonnage, 1740 tons.

Complement of Men and Officers, 650 in number.

PRINCIPAL DIMENSIONS.

	Ft.	in.
Length on the gun deck	175	9
Length of the keel for tonnage	144	6½
Breadth, extreme	47	8
Depth in hold	21	0½

ARMAMENT.

	No. of guns.	Weight of each.	Length.
		Cwts.	Ft. in.
Lower deck	28	4 of 8 in. 65	9 0
		24 32 pdrs. 56	9 6
Main deck	28	32 pdrs. 41	8 0
Quarter deck and fore-castle	16	4 32 pdrs. 41	8 0
		12 32 pdrs. carrds. 17	—
Total weight of the guns			156 tons.
Weight of the broadside in lbs.			1224 lbs.

	Weight of each.	Total weight.
	Tons. cwts. qrs.	Tons. cwts. qrs.
Weight of the principal anchors (4 in No.)	3 13 0	14 12 0

WEIGHT OF THE PRINCIPAL CABLES.

	Weight of each.	Total weight.
	Cwts. qr. lbs.	Tons. cwts. qrs.
3 hempen, of 22 inches circumference	90 1 8	13 11 0
4 chain, of 2 inches diameter of links	192 0 0	38 8 0
		51 19 0
Weight of the anchors		14 12 0
Total weight of the principal anchors and cables		66 11 0

MASTS AND YARDS.

	Length.	Diameter,	Weight.
	Feet. in.	Inches.	Tons. cwts. qrs.
Lower Masts	Main	80 0 37	14 6 0
	Fore	73 9 35	10 4 0
	Mizen	57 6 24	8 16 0
	Bowsprit	45 6 36	8 8 0
Lower Yards	Main	96 0 23	4 5 0
	Fore	82 6 20	2 16 0
	Mizen, or cross-jack	64 0 15½	1 2 0
Total weight of the masts and yards			44 17 0

ON SHIP BUILDING.

108

Total weight of the ship, with stores and equipments, to a draught of water	Afore	21	6	} 3028
	Aft	28	6	
Weight of the hull, to a draught of water	Afore	13	0	} 1600
	Aft	17	9	
Weight of the material received on board				1428

FOURTH RATE. 50 guns. Tonnage, 2082 tons. FRIGATE.

Complement of Men and Officers, 500 in number.

PRINCIPAL DIMENSIONS.

Length on the gun deck					Ft.	in.
					176	0
Length of the keel for tonnage					144	6½
Breadth, extreme					52	8½
Depth of hold					17	1

ARMAMENT.

	No. of guns.	Weight of each.	Length.
		Cwts.	Ft. in.
Main deck	28	6 of 8 in. ... 65 ...	9 0
		22 32 pdrs. ... 56 ...	9 6
Quarter deck and forecastle	22	32 pdrs. ... 45 ...	8 6
Total weight of the guns			130 tons, 12 cwts.
Weight of the broadside in lbs.			908 lbs.

	Weight of each.	Total weight.
	Tons. cwts. qrs.	Tons. cwts. qrs.
Weight of the principal anchors (4 in No.)	3 10 0	14 0 0

WEIGHT OF THE PRINCIPAL CABLES,

	Weight of each.	Total weight.
	Cwts. qrs. lbs.	Tons. cwts. qrs.
3 hempen, of 21½ inches circumferenca	86 0 16	12 8 1
4 chain, of 2 inches diameter of links	192 0 0	38 8 0
		50 16 1
Weight of the anchors		14 0 0
Total weight of the principal anchors and cables		64 16 1

MASTS AND YARDS.

		Length.		Diameter.		Weight.		
		Feet.	in.	Inches.		Tons.	cwts.	qrs.
Lower Masts	Main	83	7	37	14	6	0	
	Fore	77	0	35	10	18	0	
	Mizen	67	6	24	5	1	2	
	Bowsprit	45	6	36	8	8	0	
Lower Yards	Main	96	0	23	4	4	0	
	Fore	82	6	20	2	16	0	
	Mizen, or cross-jack	64	0	15½	1	2	0	

Total weight of the masts and yards 46 15 2

Total weight of the ship, with stores and equipments,
to a draught of water Feet. in. Tons.

Afore	20	0	} = 2200
Aft	21	0	
Afore	18	6	} = 1308
Aft	17	6½	

Weight of the hull, to a draught of water Afore 18 6 } = 1308
Aft 17 6½ }

Weight of the material received on board, in tons 892

FIFTH RATE. 42 guns. Tonnage, 1084 tons.

Complement of Men and Officers, 320 in number.

PRINCIPAL DIMENSIONS.

	Ft.	in.
Length on the gun deck	151	9½
Length of the keel for tonnage	127	0½
Breadth, extreme	40	0½
Depth in hold	12	9

ARMAMENT.

	No. of guns.	Weight of each.		Length.	
		Cwts.		Ft.	in.
Main deck	28	2 of 8 in.	50	7	0
		26 32 pdrs.	39	7	6
Quarter deck and fore-castle	14	4 32 pdrs.	39	7	6
		10 32 pdrs. carrds.	17	—	—
Total weight of the guns				72	tons.
Total weight of the broadside in lbs.				708	lbs.

Weight of the principal anchors (4 in No.)	Weight of each.	Total weight.
	Cwts.	Tons. cwts. qrs.
	47	9 8 0

WEIGHT OF THE PRINCIPAL CABLES.

	Weight of each.			Total weight.		
	Cwts.	qrs.	lbs.	Tons.	cwts.	qrs.
3 hempen, of 18½ inches circumference	63	2	16	9	11	0
3 chain, of 1½ inch diameter of links	147	0	0	22	1	0

Weight of the anchors 31 12 0
9 8 0

Total weight of the principal anchors and cables 41 0 0

MASTS AND YARDS.

		Length.		Diameter.		Weight.	
		Feet.	in.	Inches.	Tons.	cwts.	qrs.
Lower Masts	Main	67	5	30	8	0	0
	Fore	62	4	28	6	6	0
	Mizen	53	8	22½	2	11	0
	Bowsprit	38	0	28	5	0	0
Lower Yards	Main	78	6	19	2	11	0
	Fore	67	6	16	1	18	0
	Mizen, or cross-jack	55	0	13	0	15	0
Total weight of the masts and yards					27	1	0
Total weight of the ship, with stores and equipments, to a draught of water					Afore	18	0
					Aft	19	4
					} = 1592		
Weight of the hull, to a draught of water					Afore	10	6
					Aft	14	6
					} = 760		
Weight of the material received on board, in tons							832

SIXTH RATE. 26 guns. Tonnage, 913 tons.
Complement of Men and Officers, 240 in number.

PRINCIPAL DIMENSIONS.

	Ft.	in.
Length on the gun deck	130	0
Length of the keel for tonnage	105	9
Breadth, extreme	40	7½
Depth in hold	11	6

ARMAMENT.

	No. of guns.	Weight of each.		Length.	
		Cwts.		Ft.	in.
Main deck	18	2 of 8 ins.	50	7	0
		16 32 pdrs.	40	7	6
Quarter deck and forecastle	8	2 32 pdrs.	40	7	6
		6 32 pdrs.	25	6	0
Total weight of the guns			48 tons,	10 cwts.	
Total weight of the broadside in lbs.			452 lbs.		

	Weight of each.		Total weight.	
	Cwts.		Tons.	cwts. qrs.
Weight of the principal anchors (4 in No.)	38		7	12 0

F 3

WEIGHT OF THE PRINCIPAL CABLES.

	Weight of each.	Total weight.
	Cwts. qrs.	Tons. cwts. qrs.
2 hempen, of 17 inches circumference	54 0 ...	5 8 0
3 chain, of 1½ inch diameter of links	126 3 ...	19 0 0
		24 8 0
Weight of the anchors		7 12 0
Total weight of the principal anchors and cables		32 0 0

MASTS AND YARDS.

	Length.	Diameter.	Weight.
	Feet. in.	Inches.	Tons. cwts. qrs.
Lower Masts { Main	66 0	28 ...	7 16 0
{ Fore	60 0	26 ...	6 3 0
{ Mizzen	53 6	20 ...	2 8 1
{ Bowsprit	34 0	26 ...	1 5 0
Lower Yards { Main	71 0	17 ...	2 10 0
{ Fore	61 0	14½ ...	1 14 0
{ Mizzen, or cross-jack	50 0	12 ...	0 14 2
Total weight of the masts and yards			22 10 3

Total weight of the ship, with stores and equipments, to a draught of water	Feet. in.	Tons.
	Afore 16 0	} =960
	Aft 17 0	
Weight of the hull, to a draught of water	Feet. in.	Tons.
	Afore 10 5	} =510
	Aft 14 4	
Weight of the material received on board, in tons		450

SLOOP, rigged as Ship. 18 guns. Tonnage, 462 tons.

Complement of Men, including Officers, 130 in number.

PRINCIPAL DIMENSIONS.

Length between the perpendiculars	Ft.	in.
Length of the keel for tonnage	92	10½
Breadth, extreme	30	7
Depth in hold	8	0

ARMAMENT.

	No. of guns.	Weight of each.	Length.
		Cwts.	Ft. in.
Upper deck	18 { 2 32 pdrs. ...	25 ...	6 0
	{ 16 32 pdrs. ...	17 ...	—
Total weight of the guns		16 tons, 2 cwts.	
Weight of the broadside in lbs		288 lbs.	

Weight of the principal anchors (4 in No.)	Weight of each.		Total weight.	
	Cwts.	...	Tons.	cwts. qrs.
	23	...	4	12 0

WEIGHT OF THE PRINCIPAL CABLES.

	Weight of each.			Total weight.		
	Cwts.	qrs.	lbs.	Tons.	cwts.	qrs. lbs.
hempen, of 14 inches circumference	36	2	16	1	16	2 16
chain, of 1½ inch diameter of links	90	3	0	13	12	1 0
				15	8	3 16
Weight of the anchors				4	12	0 0
Total weight of the principal anchors and cables				20	0	3 16

MASTS.

Masts		Length.		Diameter.		Weight.	
		Feet.	in.	.Inches.	Tons.	cwts.	qrs.
Masts	Main	57	6	...	24	...	3 10 0
	Fore	52	6	...	22½	...	2 15 0
	Mizen	47	6	...	18	...	1 10 0
	Bowsprit	29	0	...	22½	...	2 4 0
Total weight of the masts						9	19 0
Total weight of the ship, with stores and equipments, to a draught of water						Afore	8 9 } = 480
						Aft.	10 11 }

PART

Scantlings or Dimensions of the principal portions of Her Majesty's

	110 guns.	90 guns.	80 guns.
	Ft. in.	Ft. in.	Ft. in.
Length of the gun deck between the perpendiculars, from the aft side of the rabbet of the stem to the fore side of the rabbet of the stern post	204 0	207 4	190 0
Length on the load water line, from the fore edge of the rabbet of the stem to the after edge of the rabbet of the stern post	203 0	208 0	189 0
Length between the perpendiculars from which the keel for tonnage is derived, viz., "from a perpendicular at the height of the upper deck at the fore part of the stem, to a perpendicular from the back of the post at the height of the gun deck lower sills".	207 6	210 2½	192 3
Length of the keel for tonnage	166 5½	170 7½	155 3
Breadth, extreme, from outside to outside of wales	60 0	56 0	56 9
Breadth, extreme, for tonnage, or supposing the thickness of the plank of the bottom to be continued up	59 2	55 2	56 0
Breadth, moulded, or to the outside of the frame timbers	53 4	54 4	55 3
Breadth at the top timber line of dead flat or midship sections	45 0	47 0	44 0
Depth in hold, measured from the inner edge of the upper side of the limber strake to the upper side of the lower deck beam	23 9	23 4	23 4
Burthen in tons	3099½	2761½	2589½
Gun deck ports, fore and aft	3 6	3 6	3 6
" " " deep	2 11	2 11	2 11
" " " sills from deck	2 4	2 3	2 4
Middle deck ports, fore and aft	3 5
" " " deep	2 11
" " " port sill from deck	1 11

CIX.

Ships, usually termed SCHEME OF SCANTLINGS.

Frigates, 50 guns.	Frigates, 28 guns.	Corvette, 18 guns.	Steam sloop.	Screw steam sloop.	Schooner.	80 guns, screw.
Ft. in.	Ft. in.	Ft. in.	Ft. in.	Ft. in.	Ft. in.	Ft. in.
180 0	140 0	120 0	180 0	193 7½	80 0	230 0
180 6	120 5	185 0	77 8	229 4
183 0	124 9	194 4½	80 10	233 3
146 10¼	113 9½	99 6	99 6	169 9¼	65 5½	194 7½
52 8	41 8	37 6	36 0	85 0	23 3	55 3
52 2	41 0	37 2	35 8	34 6	23 0	54 6
51 4	36 8	35 0	33 11	22 7	53 8
44 6	33 6	32 9	21 2	41 6
16 3	11 1	21 0	20 5½	9 10	24 6
2125¾	1051½	731¾	1057	1074¾	182¾	3074
.....	3 6
.....	2 11
.....	2 3
.....
.....
.....

SCHEME OF SCANTLINGS—continued

	110 guns.	90 guns.	80 guns.
Upper deck ports, fore and aft	Ft. in. 3 5	Ft. in. 3 6	Ft. in. 3 5
" " " deep	2 11	2 11	3 0
" " " port sill from deck	1 11	1 11	1 11
Quarter deck ports, fore and aft	3 1	3 0	3 1
" " " deep	2 8	2 8	2 8
" " " port sill from deck	1 7	1 8	1 7
Main keel, of elm.			
Square amidships	1 8	1 8	1 7
Fore end sided	1 6	1 5	1 3½
After end sided	1 3	1 5	1 3
False keel, elm. Thick	No. 2 { 6 4 }	0 10	0 8
Main keel, elm.			
Horizontal scarphs to be, long	4 9	4 9	4 6
Bolted with bolts of . . . Diameter	0 1½	0 1½	0 1½
Main stem, English oak.			
To be moulded	1 8	1 10	1 7
Sided at the head	2 3	1 8	1 7
Sided at the lower cheek	1 8	1 8	1 5
And to diminish at the junction with the keel to	1 6	1 5	1 3½
Apron, to be English oak.			
Sided at the head	2 3	1 8	0 11
Sided at the lower cheek	1 8
Sided at the fore foot	1 6	1 5
And to be moulded as shown by the drawing for building	1 0	1 0
Stern post, of English or African oak.			
Sided at upper end	2 1	1 10	1 10
Sided at the lower end, as the keel	1 3	1 5	1 3
Inner post. Fore and aft at the head	1 2	1 2	1 2
" " Fore and aft at the heel	1 8	1 6	1 6
Rising wood. In midships, thick	0 8	0 8	0 6
" " " " broad	1 10	1 8	1 6
Height of cutting down in midships above the lower edge of the rabbet of the keel	2 10	2 10	2 10

SCHEMKS OF SCANTLINES—continued.

Frigates, 50 guns.	Frigates, 29 guns.	Corvette, 18 guns.	Steam sloop.	Screw steam sloop.	Schooner.	80 guns, screw.
Ft. in.	Ft. in.	Ft. in.			Ft. in.	Ft. in.
3 6	3 0	3 0	2 6	3 5
2 11	2 8	3 4	2 1	2 11
1 11	1 11	0 8	0 10	1 11
3 3	2 11	3 8
2 10	2 5	3 4
1 10	1 7	1 6
1 6	1 4	12 by 15	Inches. 14 by 16	Inches. 14 by 13	Inches. 10 by 12	1 8
1 2	12 by 16	11	8 by 12	1 4
1 2	10½	12 by 16	14	8 by 12	1 4
2 No. { ⁶ ₄ }	6	6	0 6
5 9	Ft. in. 5 0	Ft. in. 4 9	Ft. in. 3 0	6 0
0 1	0 0½	0 0½	0 0½	0 1½
1 6	1	1 4	1 3	1 8
1 6	1 3	1 3	1 1	1 7
1 5	15	1 3	1 7
1 2	10½	1 0	0 11	0 8	1 4
.....
.....
.....
1 6	15½	1 3	1 5	0 11	1 8
1 2	10	1 0	{ ^{1 5} _{2 0}	0 8	1 3
1 1	0 9	Fore & aft. 0 10	0 7
1 6	1 3	1 9	1 0
0 8	1 2
1 6
2 8	2 6	2 0	1 8	1 7	2 0

SCHEME OF SCANTLINGS—continued.

	110 guns.	90 guns.	80 guns.
Floors. Sided	Inches. 14 to 16	Inches. 14 to 15	Inches. 15 to 16
" Moulded	16½	16¾	17
1st Futtocks. Sided	14 to 15½	14 to 15	14 to 15
" Moulded	15	14	14½
To be coaked to the floor timbers, and bolted with square bolts of iron.			
Diameter	⅞	⅞
2nd Futtocks. Sided	13½ to 14½	13½ to 14	13½ to 15
" Moulded	14	13¾	13¾
3rd Futtocks. Sided	13½ to 14½	13½	13½ to 14½
" Moulded	13¾	13½	13½
4th Futtocks. Sided	13 to 13½	12½ to 13	13 to 13½
" Moulded	13½	13	12¾
5th Futtocks. Sided	13 to 13½	12 to 13	12½ to 13
" Moulded	13½	13	12½
6th Futtocks. Sided	13 to 13½	11½
" Moulded	13½	11
The other timbers to make up the required lengths to follow these proportions.			
Keelson. To be square	Ft. in. 1 8	Ft. in. 1 8	Ft. in. 1 6
Coaked or doweled to the floors, or long and short-armed floors. Scarphs to be, long	5 6	5 6	5 6
Keelson bolts, in diameter	0 1½	0 1½	0 1½
" " number through each floor	0 1	0 1	0 1
Keelson side, to be coaked, and also bolted with bolts of . Diameter	0 1½	0 1½	0 1½
Keelson side Long	30 0	30 0
Stemson, to give shift to the scarphs of the stem and apron.			
To be sided	1 3
Moulded at the head	1 0	1 2
Moulded at the lower end	1 3
Bolted with bolts at the lower part, of Diameter	0 1½	0 1½
At the head	0 1½	0 1½
Bottom plank. To be thick	0 5	0 5	0 5
And this part, from 3 feet below the light water line upwards, to be of the very best quality of English oak.			

SCHEME OF SCANTLINGS—continued.

Frigates, 50 guns.	Frigates, 28 guns.	Corvette, 18 guns.	Steam sloop.	Screw steam sloop.	Schooner.	80 guns, screw.
Inches. 14 to 15	Inches. 12 to 14	Inches. 11 to 12	Inches. 10 to 12	Inches. 9 to 11	Ft. in. 0 8½	Inches. 15 to 16
15½	10½	14 to 9	13	11	0 6½	16½
13 to 14	10½ to 11½	10½ to 11	10 to 12	9 to 11	0 8½	15 to 16
13	9½	8½	11½	9½	0 6½	15½
7	7	7	7
13 to 14	10 to 10½	10 to 9	9 to 10	9 to 10	0 8	13½ to 15
12	8½	8	10½	8½	0 6	14½
11½ to 12½	9½ to 10	9½ to 9	9 to 10	8½	0 7½	13 to 14
11½	7½	7	9	7½	0 5½	14
11 to 11½	9½ to 10	9	8 to 8½	8	13 to 13½
10½	7½	7½	7½	7	13½
10½ to 11	9½ to 10	8	7½	13 to 13½
10½	7	6½	6	13½
.....	12½ to 13
.....	12½
Ft. in.			Ft. in.	Ft. in. Deep.		Ft. in.
1 5	14	1 1	1 2	{ 0 10 1 2 Sided.	0 10	1 8
5 6	5 6	5 6
0 1½	1½	0 1½	0 1½	0 1½
0 1	0 1	0 1	0 1
0 1½	0 1½	0 1½
28 0	Engine sleepers. From 10 to 15 ft. beyond engine room, bulk.	
.....	1 4
.....	0 8
.....
.....
0 5	4	3	0 4	0 3½	0 2½	0 5

SCHEME OF SCANTLING—continued.

	110 guns.	90 guns.	80 guns.
	Ft. in.	Ft. in.	Ft. in.
Main wales, English oak. Thick . . .	0 10	0 10	0 9
Middle wales, English oak. Thick . . .	0 5½
Channel wales. Thick	0 5	0 5	0 5
Sheer strakes, crown plank, of long lengths	0 4	0 4½	0 4½
Orlop shelf pieces. Broad	1 2	1 3
" " " Deep	1 0	0 9
" " " Bolts . Diameter	0 1½	0 1½
Orlop beams. Moulded	1 3	1 2	1 3
" " Sided	1 4	1 2	1 3
" " To round up	0 4	0 4	0 3½
Gun deck beams. Moulded	1 5	1 4	1 4½
" " " Sided	1 5	1 4	1 4½
" " " To round up	0 7	0 7	0 5½
" " " Flat, thick	0 4½	0 4½	0 4
Middle deck beams. Sided	1 3
" " " Moulded	1 1
" " " To round up	0 8
" " " Flat, thick	0 4
Upper deck beams. Moulded	1 0	1 2	1 0½
" " " Sided	1 1	1 1	1 1½
" " " To round up	0 8	0 8	0 7½
" " " Flat, thick	0 4	0 4	0 4
Quarter deck beams. Moulded	0 10	0 10	0 8
" " " Sided	0 11	0 10	0 9
" " " To round up	0 8½	0 8½	0 8½
" " " Flat, thick	0 4	0 4	0 3
Forecastle beams. Moulded	0 8½	0 10	0 8
" " " Sided	0 9½	0 10	0 9
" " " To round up	0 8½	0 8½	0 8½
" " " Flat, thick	0 4	0 4	0 3
Round house beams. Moulded	0 6½	0 6	0 5½
" " " Sided	0 8	0 7½	0 7½
" " " To round up	0 8	0 8	0 8
" " " Flat, thick	0 2½	0 2½	0 2½

SCHEME OF SCANTLING—continued.

Frigates, 50 guns.	Frigates, 36 guns.	Corvette, 18 guns.	Steam sloop.	Screw steam sloop.	Schooner.	80 guns, screw.
Ft. in. 0 8	Ft. in. 0 6	Ft. in. 0 6	Ft. in. 0 6½	Ft. in. 0 6½	Ft. in. 0 4	Ft. in. 0 10
.....
.....	0 6
0 4	0 4	0 4	0 3	0 5
.....	Platform. 0 10
.....	0 6
0 1½	0 0½
0 9½	0 7	1 3
0 10½	0 7	1 3
0 2	0 3	0 4
LOWER DECK.						
1 0½	0 9	0 6	0 9	1 4½
1 1½	0 6	0 8	0 7½	1 4½
0 5	0 3	0 5	0 6
.....	0 2½	0 4½
.....
.....
.....
1 1½	0 11½	0 10½	0 9	0 7	0 11
1 2	1 0	0 11	0 10½	0 2	1 0
0 8	0 8	0 7½	0 6	0 5½	0 8
0 4	0 4	0 4	0 3	0 4
0 9½	0 7	0 10½	0 8	0 11
0 10½	0 8	0 11	0 9	1 0
0 8	0 6	0 7½	0 6	0 8
0 3	0 4	0 4	0 4
0 9½	0 8
0 10½	0 9
0 8	0 6
0 3	0 4
.....
.....
.....
.....

SCHEME OF SCANTLINGS—continued.

	110 guns.	90 guns.	80 guns.
<i>Weight of Iron Knees used to attach the Beams of the several Decks to the sides of the ship.</i>			
	Cwt. qr. lb.	Cwt. qr. lb.	Cwt. qr. lb.
Orlop Weight	3 0 14	3 0 0	2 3 0
Lower deck "
Gun deck "	3 2 21	3 2 10	3 1 0
Middle deck "	2 3 14
Upper deck "	2 0 3	2 2 10	2 0 0
Quarter deck and fore-castle "	1 1 22	1 2 0	1 1 8
Fore step, to be made by two crutches.			
Sided	Ft. in. 1 1	Ft. in. 1 0	Ft. in. 1 1
Asunder in the clear	4 0	3 6	3 6
Long	13 to 14 ft.	14 0	14 0
Bolted with 10 bolts, of . Diameter	0 1½	1½ to 1¾ in.	0 1½
Main step. Sided	3 3	3 0	3 0
" Deep on the keelson	2 4	1 6	1 6
Length such as will allow it to pass clear of the well stantions.			
Mizen step. Sided	2 0	1 10	1 10
" Deep
" Bolted with bolts. Diam.	0 1½	0 1½	0 1½
Riding bitts. Fore pair, square	1 10	1 7
" " After pair, square	1 11	1 8	1 8
" " Above the deck	5 1	4 10	4 10
Cross pieces to riding bitts.			
Fore and aft way	1 8	1 6	1 6
Deep	1 7	1 4	1 4
Main geer and topsail sheet bitts.			
To be of African timber, and square	1 2	1 2	1 1
Main-mast partners. Deep	1 6	1 5	1 5
" " Broad	1 5	1 4	1 4
" " Above the beam	0 8	0 8	0 8
Gun deck, breast hook. Sided	1 3	1 2	1 2
" " " Long	18 0	16 0
Bolted with bolts of . . Diameter	0 1½	0 1½	0 1½
Gun deck clamps. Thick	0 9	0 8	0 8
Gun deck shelf. Broad	1 4	1 3	1 4
" " Deep	1 4	0 10	1 2
Bolted with bolts of . . Diameter	0 1½	0 1½	0 1½
Gun deck spircketting. Thick	0 6½	0 7	0 7

SCHEME OF SCANTLINGS—continued.

Frigates, 50 guns.	Frigates, 28 guns.	Corvette, 18 guns.	Steam sloop.	Screw steam sloop.	Schooner.	80 guns, screw.
Cwt. qr. lb.	Cwt. qr. lb.	Cwt. qr. lb.		Platform. Cwt. qr. lb.		As 80-gun ship.
.....	0 1 16	
1 3 0	
.....	1 1 12	
.....	
2 2 0	1 13 10	1 1 0	
1 3 0	1 1 0	0 3 1	
Ft. in.						
1 1	
3 5	
14 0	
0 1½	
2 10	
1 10	
1 9	
1 7	
0 1	
1 5	
1 6	
4 10	
1 4	
1 3	
1 1	
1 2	
1 4	
0 7	
.....	
.....	
.....	
.....	
.....	
.....	
.....	

SUMMARY OF SCANTLINGS—continued.

	110 guns.	90 guns.	60 guns.
	Ft. in.	Ft. in.	Ft. in.
Gun deck waterways. Sided	0 11	0 11	0 11
" " " Deep	1 2½	1 1	1 2½
Middle deck shelf. Broad	1 8
" " " Deep	1 0
" " " Bolts . Diameter	0 1½
Middle deck waterway. Sided	0 10½
" " " Deep	1 2½
Middle deck spirketting. Thick	0 5½
Upper deck, deck hook. Sided	1 2	1 0	1 1
" " " " Bolts Diameter	0 1½	0 1½	0 1½
Upper deck shelf. Broad	1 2	1 0	1 4
" " " Deep	1 0	0 8	0 10
" " " Bolts . Diameter	0 1½	0 1½	0 1½
Upper deck waterway. Moulded	0 10	0 10	0 10
" " " Deep	1 2	1 0	1 1½
Upper deck spirketting. Thick	0 5	0 5	0 5
Quarter deck clamps. Thick	0 4	0 4
Quarter deck shelf. Broad	1 0	1 0	1 2
" " " Deep	0 9	0 7½	0 8
" " " Bolts . Diameter	0 1	0 1	0 1
Quarter deck waterways. Moulded	0 9	0 9	0 9½
" " " Deep	0 11	0 10	0 11
Quarter deck spirketting. Thick	0 3	0 4	0 3½
Cat heads. Fore and aft	1 8	1 7½	1 7
" " " Deep	1 6	1 5	1 5
Rudder head, to be in diameter	2 3	2 3	2 3
Iron riders in the hold. Broad	0 6	0 6	0 6
" " " Thick	0 1½	0 1½	0 1½
" " " Bolts Diam.	0 1½	0 1½	0 1½

PART XX.

Method of expanding (by means of the Sheer Drawing or Draught) the Bottom of a Ship on Paper, or a Delineation of the whole Surface of the outside of the Timbers that compose the Frame of her; a mechanical operation that enables the practical ship builder to arrange a disposition of the plank and thickstuff as a covering to the timbers of the ship under the breadths, lengths, and positions that will be the most advantageous for strength to the ship and economy in the conversion of the store of planking.

THE expansion of the outer surface of the timbers of the frames being attended with some trouble, and requiring a little more attention than the other ordinary duties of the draughtsman, it may be thought by some that such a delineation of the planking might be dispensed with, without its being detrimental to the process of planking or skinning the bottom of the ship. True it is that the ship builder may, with the quick eye that long practice has given to him, determine at a glance the positions of the least girt of the body from the keel to the wales in the fore and after portions of the ship, and by girding the frame of the vessel at these places ascertain the contraction or extension of the breadths of the bottom plank that may be necessary to make it fit to the timbers or ribs under the most advantageous form. But the surface presented by the bottom of a large ship is a wide field for the human eye to travel over and fix on it the station of each butt or end of the numerous planks composing the skin or covering of the timbers, besides having at the same time to bear in mind also, that they have reference to the arrangements of the internal portions of the planking; and thence time will be saved and a more perfect floating structure be built, if the following method be adopted (even under a rough guise) to describe, by lines on paper, the edges of the wales, diminishing plank, and plank of the bottom.

The required expansion is obtained from the sheer drawing of the ship (Plate 1), with the aid of a midship section of her (Plate 2), on which the draughtsman has shown the sectional

Sketch 1.
Expansion of Plank outside. Fore Body.

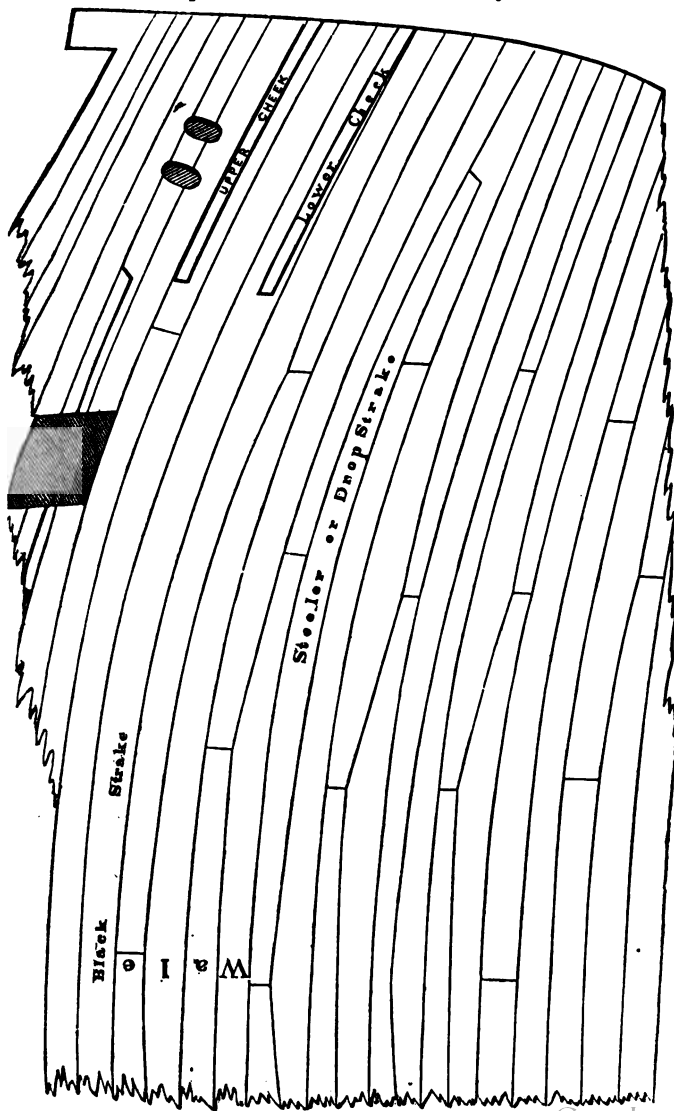

Sketch 2.
Expansion of Plank. Midship Body.

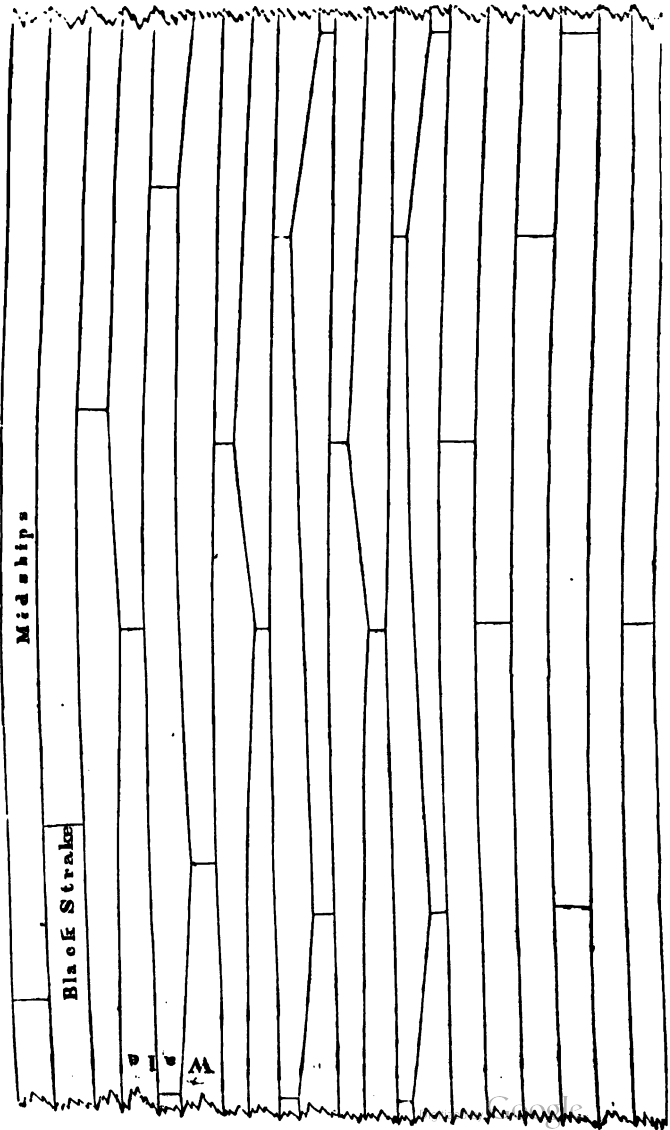

Sketch 3.

Expansion of After Plank₁ (outside).

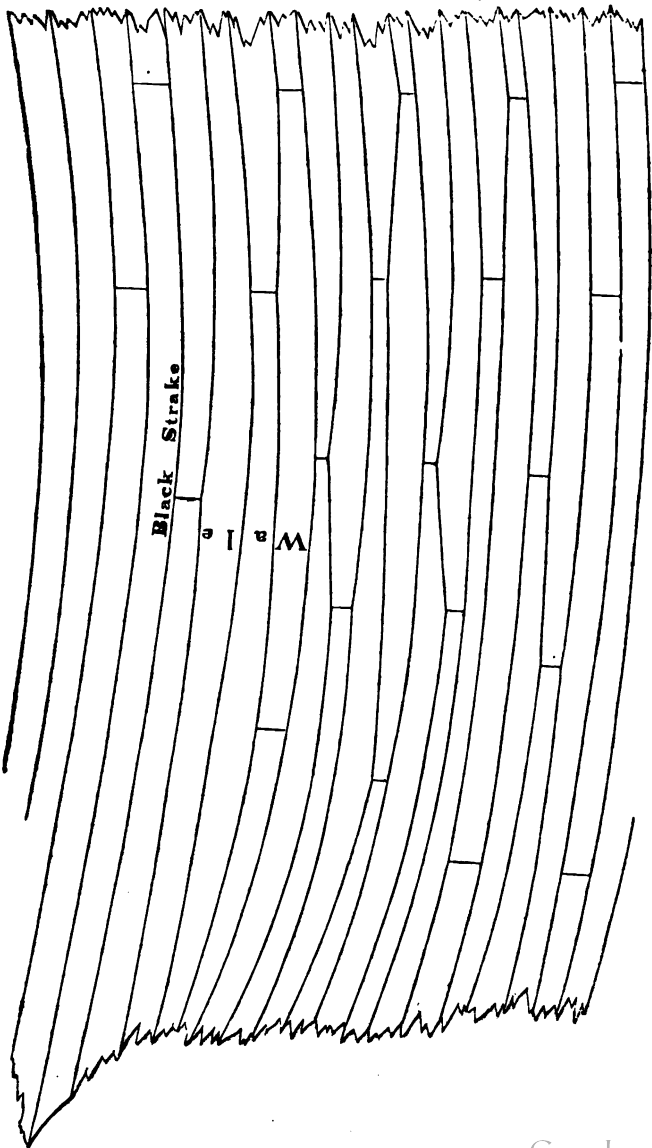

areas of the different strakes of wale, diminishing plank, and plank of the bottom.

The base line of the expansion is assumed as a representation of the middle of the rabbet of the keel, or the lower boundary of the surface of the timbers of the frame, of which surface the proposed expansion is a development (Sketch 2, of Expansion, p. 122).

This base line will be necessarily a straight line, the keel partaking of no part of the form of the body of the ship; therefore from the sheer draught (Plate 1) take the stations of the frames as shown on that drawing by straight lines at equal distances apart, and transfer them to the straight line, assumed as the base line, to represent the middle line of the rabbet of the keel, the after end of such line being governed in length by the after edge of the rabbet of the post at the height of the middle of the rabbet of the keel; and the fore end running as far forward as the form given to the ship forward, makes the middle line of the rabbet of the keel a straight line.

The heights (Plate 1) on the sheer draught of the ship from the line representative of the middle of the rabbet of the keel to the lines descriptive of the edges of the several portions of the planking, would be projected heights, or, artistically speaking, fore-shortened heights; but the expansion requires that the shortened height should be extended to its whole length as an ordinate of the surface of which it is a part; and to obtain such, the length must be taken round the section of the frame on the body Plan, or what is termed the girt, to the point on the section which is descriptive of the line of wales, diminishing plank, or plank of the bottom (as shown in Sketch 2, of Expansion, p. 122).

The midship frame and its planking, under these circumstances, is first expanded in height, which is done by penning a thin batten round the midship section (Plate 2), and marking on it the middle of the rabbet of the keel and the points denoting the edges of the wales (as N), sheer strakes,

upper and lower sides of ports, &c.; and this batten being allowed to fly straight, is applied to the straight line, which is assumed to be representative of the midship section in the sheer plan. The mark on the batten, which was made to denote the relative position of the middle line of the rabbet of the keel, being kept well with the base line before described, and the batten lying square to that base line, the expanded heights, from the middle line of the rabbet of the keel to the several portions of the planking, viz., wales, ports, &c., are transferred from the batten to the paper.

The heights of the wales, ports, and sheer strakes, &c., as determined by the draughtsman on the sheer drawing (Plate 1), are next to be transferred from the sheer plan to the body plan; and these are again, by their breadths, thus obtained on the body plan, to be run off or developed for length on the half-breadth plan (as shown in Plate 1), as curves, which in the half-breadth plan are descriptive of the wales, port, sill lines, sheer strakes, &c., through the length of the ship. Pen or bend thin battens round these curves, and mark on each batten the points where these lines severally cross the line denoting the midship section of the half-breadth plan, and also where each timber, as denoted by a straight line, crosses the same curves, viz., those that, in the half-breadth plan, severally point out the line of the wales, sheer strakes, water lines, &c., thus giving the girts of these points from the midship section each way. This will give for length, the ordinates of the expansion which are due to the several points of the wales, sheer strakes, water lines, &c. For height, in a similar manner pen battens to the girts of the other sections in the fore and after bodies of the body Plan, from the middle of the rabbet of the keel, and mark on them the positions of the upper and lower edges of wales, sheer strakes, height of water lines, and decks at the side, &c.

Under these considerations, for each point of these lines there are two expanded dimensions obtained, one for height and the other for length; and the two are capable of being

set off, from common standards: for length from the midship section, each way; for height, from the base line, assumed as the middle line of the rabbet of the keel; but the expansion, being a surface, admits but of two dimensions for each point, and thence each point of the planking can be determined by the method that has been given, and the full inner surface of the planking be depicted; and the doing so will allow the practical builder to arrange the butts of his planking on paper on his drawing board. A rough block model will greatly assist the expansion drawing, as a batten can be pinned on it, and the best positions for the planking be determined by it.

REFERENCES TO THE SKETCHES OF THE EXPANSION OF THE FORE, MIDSHIP, AND AFTER BODIES FOR THE PLANKING OF THE OUTSIDE OF A SHIP.

These three would form in practice one expansion, the restricted size of the plates of this rudimentary work requiring the division that has been made into fore, midship, and after bodies.

On the fore body expansion (Sketch 1, p. 121), made as described by the text, the position of the hawse holes, bow port, cheeks of the head, &c., are marked. The cheeks are placed in the centre, or nearly so, of a plank, that the planks may be caulked or made water-tight in their seams or joints without the cheeks being removed or unbolted, an operation that would be attended with some expense and loss of time. The butts are also shown, with three planks between them.

The several methods of working the planks, under the conversions styled top, and butt and fair edged, are also shown; and a steeler, to take out the sny of the plank, is also delineated.

This description of the fore body expansion will serve to elucidate the terms for the form of plank shown on the midship and after body expansions.

PART XXI.

Description of the Fittings to the Riding or Mooring Bitts.—Common—
 Elliot's.—Description or Reference to Plate 5.—Deck Hook, how formed.
 Iron Crutches.—Iron Breast Hooks.—Cleats, their form and uses.

Sketch 4.

Sketch of the Riding or Mooring Bitts, as fitted in Her Majesty's Ships of War.

Elliot's Bitts.

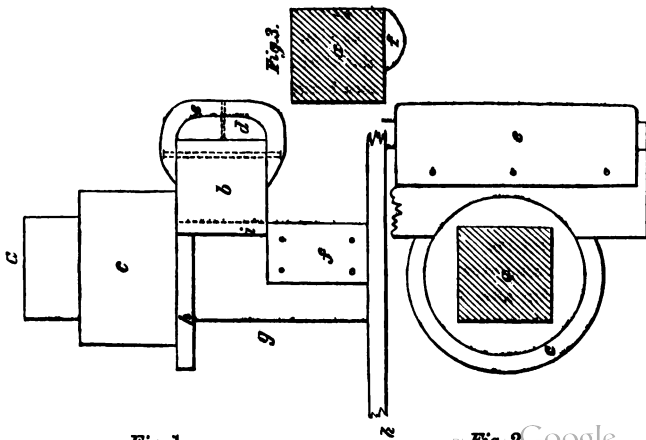
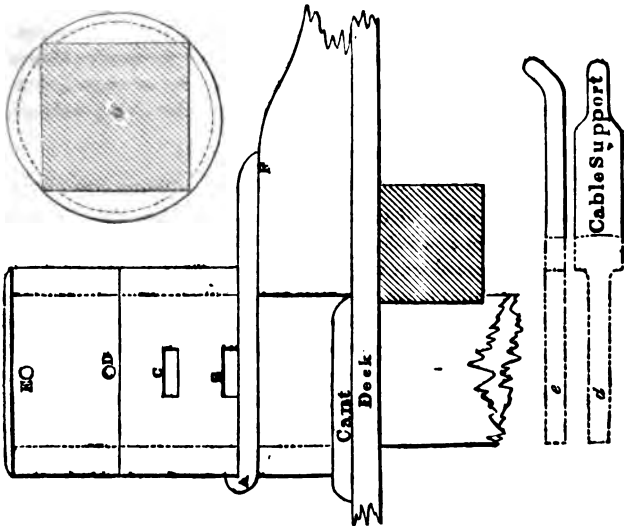

Fig. 1.

DESCRIPTION OF SKETCH 4.

Sectional elevations and plans of riding bits: the one as commonly fitted in ships of war, the other as fitted on a design suggested by Admiral Elliot, of the British Navy, to be practised where want of room on the deck or platform for the training of the guns makes it expedient that a portion of the common method of fitting, viz., the cross-piece, should be dispensed with. The methods of arming both descriptions of mooring bits with iron are also shown, such fortifications being necessary to protect the mooring bits when chain or iron cables are used; but these fittings are so adapted, that the hempen or rope cables may be worked round them without injury to the cables.

REFERENCES TO THE SKETCH.

- Figs. 1 and 2, Riding Bits on the common plan, having a cross-piece (b).*
- a, A sectional elevation of the riding bitt above the deck (*h*). The section (*a*) being drawn on a scale, is descriptive of the size of the bitt, which, in the first-rate men of war, is 1 foot 10 inches. They are usually of oak.
 - b, Sectional elevation of the cross-piece to the bitt (*a*), which, in size, for the first-rate, is 1 foot 8 inches in the fore and aft direction, and 1 foot 7 inches deep. (*Vide* the appended scheme of scantlings for ships.) The cross-piece (*b*), which is of oak, extends across each pair of riding bits, and the ends of it project beyond them, thus tying the bits together and forming a larger surface to wind the cable round, by which means the friction is increased and the security for the cable made more firm. The cross-piece is made to clasp the corresponding riding bits of each side (or the two fore or two after ones) by what is termed a facing or scoring over them (*i*, fig. 1).
 - c, An iron casting or iron hood, which is hollow, and fitted over the square of the bitt head as shown in the plan (fig. 2), by the corresponding letter (*a*), in which sectional plan the thickness of the iron in the hood (*c*) of fig. 1 is depicted by the distance between the concentric circles containing the distinguishing letters (*c*). This casting has a flanch or projection cast to it (*k*), which forms a shelf, as it might be termed, for the turn of the cable round the bitt, to rest on; and (*d*), face piece of elm used to succour the cross-pieces (*b*).
 - e, A casting of iron employed as a shield to the cross-piece (*b*) and face piece (*d*), to preserve them from the severe friction which arises from the iron cable running over them when the cable is bitted for stopping the motion of the ship after the anchor is let go, which motion has to be checked by the cable being compressed and allowed to slip gradually round the bitt (*a*) and cross-piece (*b*).
 - f, Arming of casting iron to protect the side of the bitt (*a*) below the cross-piece

(*b*) from the rub or chafe of the iron cable. The plan section of *f* is shown in fig. 3, where *a* is a plan section of the bitt, and *f* the same of the iron casting (*f*) of fig. 1.

g, At *g* a wooden knee or standard to the bitt (*a*) is worked to support the heavy strain brought on the bitt (*a*). The bitt (*a*) usually runs down through two decks, but is not secured by a standard on the lower one.

REFERENCES TO THE SECTIONAL ELEVATION AND PLAN OF THE RIDING BITTS WHEN FITTED WITHOUT A CROSS-PIECE, OR WHEN FITTED ON A PLAN SUGGESTED BY ADMIRAL ELLIOT, OF HER MAJESTY'S NAVY.

A, Worm or thread cast in the under iron hood (*b*), forming the lower separation between the turns of the chain cable, two or three of which turns are usually taken round the bitt head when they are thus fitted.

a, Plan section of the bitt head, with the iron hood (*b*) round it.

B & C, Mortices or holes cut through the lower hood (*b*) to receive the cable supports to keep the other turns of the cable separate. The cable supports which are inserted in these mortices are described in the figure, both in plan and elevation, by sections, that of plan being marked *e*, and the elevation *d*.

D & E, Holes through the upper casting (*c*), to receive round bolts to prevent the upper turns of the cable from flying off over the bitt head when the cable is veered out for anchoring the ship.

F, Standard or wood knee to the riding bitt, to which the flange of the lower hood (*b*) is secured; but the standard (*F*) is principally designed to support the riding bitt and resist the strain brought on it. The standard to be, in height from the deck, about twice the diameter of the hempen cable.

The riding or mooring bitts on this principle are not required to be so high above the deck on to which they are placed as those fitted with a cross-piece; and although a faulty construction in the deck plan of a ship, in its not affording space for the required evolutions of the foremost guns of the battery without the removal of the cross-piece to the riding bitts, may make the bitt without a cross-piece to be a fitting that may be tolerated in practice: still, the twisting strain brought on the bitt head when the cable is veered round it has a great tendency (from the bitt head being unaided by the cross-piece, and isolated, as it were, from any support from the other bitt) to destroy the bitt by wrenching it out of its place. In some instances, when thus fitted in the navy, such an occurrence to the riding bitts took place, and the evil was in a measure rectified in the subsequent fittings on this plan by deep carlings, or as it were shores, being worked athwartships between the two bitts. This plan would soon be obsolete if the deck plan of the naval construction was made with due regard to the requirements of the naval artillerist for working and training the guns.

DESCRIPTION OF PLATE 5.

Deck Hook, descriptive of the portion of the Frame of the Ship alluded to at page 55.

Fig. 1. The parts marked *e e* are of wood, and are called ekings. They are in depth the same thickness as the moulding of the beams, and are scarphed together at the middle as shown by the fig. An iron hook is then worked over them in thickness as described in the fig., of the breadth of 5 or 6 inches, and the whole, or the wood ekings and the iron hook, bolted firmly to the timbers and plank of the ship as shown in the sketch, the bolts (*b*) decreasing in diameter from those shown at the scarph of the ekings to the outer arms. The bolts in the throat of the iron hook, in a large ship, are usually 1½-inches bolts; and at the ends of the same $\frac{2}{3}$ or $\frac{1}{2}$ of an inch in diameter.

b & c, Figs. 2 and 3. Iron crutches or staples, marked *m*, used internally to tie the two sides of the ship together in the after extreme of the vessel, the centres of them, at *b* and *c*, being on the upper sides of the after dead-wood, and the arms laying across the heels of the timbers, so that the bolts shown in the sketch are each in separate timbers.

A & B, Figs. 4 and 5. Iron breast hooks, performing the same office in the fore extreme of the ship that the iron crutches do in the after extreme, and they are placed between the deck hooks.

Cleats or Mechanical Contrivances for the reception of the Heads and Heels of the Shores which are employed in putting together the Frames of a Ship, and those used in the several portions of her planking and of her general construction.

a, Wale cleat, or one of those which are placed on the wales after the planks so denominated are worked. The cleats are secured to them, in the Queen's service, by Mr. Blake's screws, and in the merchant service by large nails, driven on a ring to insure their removal when they are no longer required. The nails used are called spike nails. The upper score or notch of this cleat is intended to receive the head of a shore, called a wale-shore, which is placed with its head above the level, the heel or outer end being brought to the standards or uprights which usually surround building slips. These shores preserve the form while building by preventing the sides of the ship from falling outwards. The lower score receives the head of a shore, the heel of which is down on the groundways of the slip, and which heel is kept in its position by a cleat (*b*), also secured with Blake's screws or nails. These shores take, in part, the weight of the ship.

e & *d* are cleats used in working the plank, to make steps or abutments for wedges to be set against.

Fig. 8. A piece of timber with the mould laying on it, showing the connection when chocks were used instead of square heads and heels in the frame.

On the Plate 5, fig. 9, is shown a method sometimes used to succour the bag of the frame of timber, or the curved portion of it, when being hoisted into its place, over the floor ribband shown on the plate in the half section, fig. 6, the floor head being distinguished by the letters *cd*, and the floor being depicted therein as crossed over the keel. On the frame to be hoisted are marked, in its several parts, the abbreviations used to denote the several heads and heels of the timbers, viz. F. H. for floor head, 1 H. for first head, &c. Cleats of the description marked C, in this plate, are nailed to the frame in the positions pointed out by the shaded sections of wedges placed inside of it. Between these a board is placed, described by *e*, which acts as a shore, and prevents the upper and lower parts of the frame from coming together when it is being raised, and forms a ladder for the workmen to ascend the frame and fix the cross paul, or what may be termed a tie, to keep the frame to its proper spread or width athwartships. On this section will also be found the positions of the several ribbands, as marked 1st S. R., &c., which is an abbreviation of the 1st sirmark ribband. A rope or chain is, as an additional security, wound round the frame and shore at the middle of *e*, and set taut by wedges on *e*.

PART XXII.

Description of the several Modes used in Her Majesty's service for uniting the Beams to the sides of the Ship.—References to Plate 8, of a descriptive Drawing of a Compressor for the Chain Cables.

DESCRIPTION OF THE SECTIONS OF IRON KNEES TO BEAMS, AS SHOWN IN PLATE 6.

Scale, $\frac{1}{2}$ of an inch to a foot.

Fig. 1.—Iron plate knee, on Mr. Roberts's plan, with the waved arm to the beam arm, as described in fig. 3, Plate 7.

Fig. 2.—Plate knee of iron, used by Mr. Roberts for connecting the checks worked to receive the plate knees of the lower deck of line-of-battle ships, with the orlop beams of the same, the arm marked (b) running along the orlop beam, and the other arm up the check.

Fig. 3.—Front view of the beam arm of a knee, introduced by Mr. Lang, Master Shipwright of Woolwich Yard, in building the *Royal Albert*, of 120 guns. The knee, running down from the lower deck beam, passes the orlop deck, as shown in the fig.

Fig. 4.—The front view of the side arm of the same knee, with the position of the bolts. These knees have a great tendency to render the fabric firm, the knee performing the double office of a knee and a brace.

Fig. 5.—Section of a horn knee, with three bolts in the horn which clasps the beam.

Fig. 6.—Iron plate knee used by Mr. Roberts, with the intervention of a chock, to unite the orlop beams to the side of the ship.

Fig. 7.—Plate knee of fig. 3, plate 7, without the chock, the description of which is there given.

DESCRIPTION OF THE SECTIONS OF IRON KNEES TO BEAMS, AS SHOWN IN PLATE 7.

Scale, $\frac{1}{4}$ of an inch to a foot.

Fig. 1.—The section of an iron knee, for the security of the beam ends to the side of the ship, introduced into the practical carpentry of the British navy by Sir William Symonds, late surveyor of Her Majesty's navy. The section shows the thickness of the iron in the side and beam arms of the knee, which are worked to the internal planking, with the breadth of iron of the horn or clasp of the knee to the beam.

Fig. 2.—Front view of the same knee, drawn with a cast or a diagonal direction given to the side arm, being the form of iron knee that is used where the beams of one deck are adjacent to the ports on the other. The section gives the breadth of the side arm of the knee and the thickness of the horn that clasps the beam. The upper bolts, or those in the throat or thickest portion of the knee, are, in large ships $1\frac{1}{4}$ inches in diameter, the lower ones, or those in the extreme ends of the knees, being $\frac{3}{4}$ of an inch in diameter. The intermediate bolts in both side and beam arms being graduated in size between these limits of $1\frac{1}{4}$ inches and $\frac{3}{4}$ of an inch, the nib or turned-up portion of the beam arm of the knee (shown in fig. 1) is let up into the beam before the iron knee is bolted.

Fig. 3.—Side section of a beam, and a chock worked to receive an iron plate knee, introduced by Mr. Roberts, many years master shipwright in Her Majesty's service. The objection made to the use of this security of the beam end to the side of the ship is this: that the bolts in the beam arm, from being all in one range of the fibres of the wood, have a great tendency to split the beam end. The projector, Mr. Roberts, to overcome this

serious objection, made the upper arms of these plate knees in a waved form, vide fig. 1, Plate 6, which in some measure obviated the objection by keeping the bolts from being in one range at the beam end.

Fig. 4.—Front view of the chock under the beam, with the plate knees let into the chock, their thickness $1\frac{1}{4}$ inches; and descriptive also of the ends of the plate knees next the side of the ship being turned round to lay against the side of the ship, and to take two bolts through them.

Fig. 5.—Iron knee used as the security for the beam ends of the poop of a line-of-battle ship. It is usually denominated a dog plate. The upper part of the knee is formed as a round bolt, long enough to pass through the beam, as shown by the figure, the bolt being clenched on an iron ring or plate upon the upper side of it. The bolts in the side arm (A) pass through the shelf and side of the ship.

Fig. 6.—Usual hanging knee of iron, used on the lower deck beams of frigates, orlop and quarter deck beams of line-of-battle ships. The section is descriptive of the thickness of the knee at the several parts of it, and gives the positions and size of the bolts in each arm of it.

Fig. 7.—Front view of the up and down arm of the same knee (fig. 6). This knee is worked home to the internal planking without the intervention of chocks, as in the knee described in fig. 4. By this arrangement the length of the bolts is decreased, which reduces the expense of materials and the weight of the hull of the ship; the shrinkage of the chocks is avoided, and the work, from these considerations, is stronger and more economical.

Fig. 8.—Iron knee for the security of the upper deck beams of line-of-battle ships, of which fig. 12 is the front view of the side arm; also showing the horn or clutch of it to the beam. The bolts are also depicted. The same rule is used for the diameter of the bolts as was given for the lower deck knees.

Fig. 9.—Side section of the plate bolt (fig. 5). This gives the thickness of the plate iron, and the position of the bolts.

Fig. 10.—Horn knee, introduced by Sir Robert Seppings, for the security of the lower deck beams of line-of-battle ships. The dowels in the beam and shelf are shown in it, and the bolts through the horn and beam.

Fig. 11.—Section of fig. 10, giving the thickness of the side arm of it, and the breadth of the horn which clasps the beam, and the stations of the bolts for securing it.

REFERENCES TO PLATE 8,

Or a Description of the Elevation and Plan of a Compressor or Stopper used in Her Majesty's Ships for checking the Chain Cable when running out round the Riding Bitts after the Anchor has been let go.

Scale, 1 inch to a foot.

ELEVATION. FIG. (1).

- a, Section of iron pipes forming a tube for the cable to run through, the links of the cable being shown in it.
- b, A check let down through the deck (c) on to the beams, as described by the sections d, d.
- c, Deck or platform on beams.
- d, d, Beams to receive deck or platform.
- g, Compressor of iron or bent lever pivoting on the bolt f, and which, by the use of a tackle to the end, is made to force or compress the chain cable against the pipe and beam, and thus increase the friction on the riding bitts and cross-piece. The chain cable was found under such a fitting to force down the compressor and the bolt (f) which led to the introduction of the strap (e) bolted to the beams (d, d).
- m, Carlings of wood let down between the beams (d d) to form a bed for the iron pipes, a.

Fig. 2, Plate 8.

References to the Plan of the Compressor, which Plan is supposed to represent the underside of the Deck and Beams.

- a, Pipe or tube for the chain cable, which in men-of-war is governed in diameter, by being in size $\frac{3}{4}$ of the diameter of the hawse pipe in the clear.
- d, d, Undersides of the beams.
- g, A section of the compressor showing the form of it.
- k, Head of the bolt (f of elevation) on which the compressor revolves.
- h, A fan or counterbalancing arm worked in the compressor to assist the staple marked e in keeping the compressor in its place.
- i, An iron plate screwed on to the underside of the beam, to form a hard surface for the fan (h) to work upon.
- e, Strap to support the compressor (g).

This plan for the compressor, which was introduced into her Majesty's ships when iron cables first came into use, owed its invention to Captain Chasman of the British navy; the additions, viz., the fan (h) and strap (e), practice suggested, and, with these improvements, it is preferred to the numerous schemes that have been brought forward to effect the same end.

PART XXIII.

he Mechanical Power employed to raise the Anchor.—Methods used for uniting the Cable with the Capstan.—The Fittings of the Capstan should be well tested.—Power Capstan attained by Machinery not advisable for a Man-of-War.—Plate of Common Capstan, or one on which a Messenger is used.—References to the Plate.—Plate of Brown's patent Capstan, to which the Cable is brought without the intervention of a Messenger.—References to the Plate.—Windlass.

DESCRIPTION OF PLATE 10, OF THE CAPSTAN.

Scale, $\frac{1}{4}$ of an inch to a foot.

THE mechanical power employed in ships of war and in the large vessels used for commercial purposes, to heave in the cable, and thereby raise the anchor, is a modification of the wheel and axle, or of one of the six standard machines of mechanical science; it is technically denominated a capstan—one portion of which, called the barrel, round which the rope is wound, answering to the axle of the mechanical machine; the other part, the head with the bars, being analogous to the wheel of it. To set this machine in motion, a moving power (the crew or ship's company) is applied to the bars of the capstan or wheel, and the rope being by this means wrapped round the barrel of the capstan or the axle of the machine, the weight or cable is raised. The cable itself is not generally attached to the barrel of the capstan, but it is connected with it by the intervention of a rope or chain called a messenger which does pass round the capstan, and is made to unite itself firmly to the cable by what in nautical terms are styled nippers, as being expressive of the close connection they cause between the cable and the messenger. The messenger before mentioned is a rope or chain formed into a long loop, and in length, when of rope, so as to allow of three or four turns of it round the barrel of the capstan and then for each part to reach to the hawse holes, the two ends being there united to form an endless rope. When a chain messenger is used*, the links of the chain messenger are worked over studs placed on the capstan, as shown by fig. 3, which decreases the length of it by the three or four turns round the barrel or axle of the capstan which are required when a hepen messenger is used to withstand the strain brought on it, and prevent the messenger from slipping round the barrel of the capstan. The fittings of the capstan should never be slighted, the efficiency of it being essential to the safety of the ship, and its power and facility

* The links should have been shown without the stay pins.

Brown's Patent Fittings to Capstan, without Messenger.

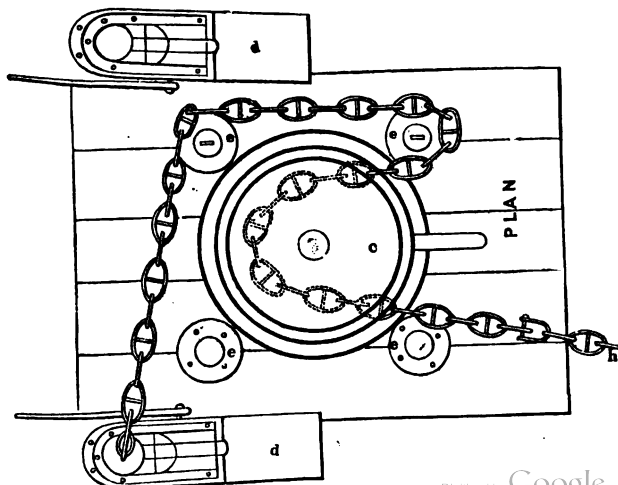
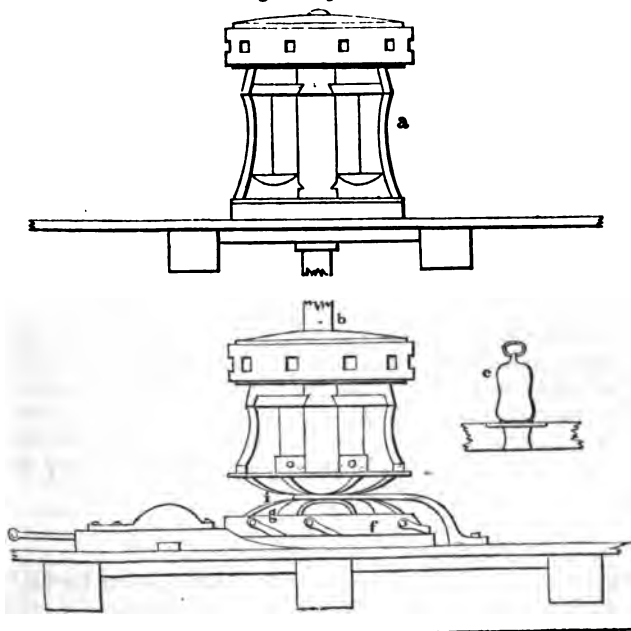

for use should be increased as much as the simplicity required in all mechanical agents for ship use will allow. But the use of mechanical contrivances for increase of power in the capstan, which involve iron in their construction, should, for nautical purposes, be adopted with caution, as the corrosion which rapidly takes place in that metal, tends to render them inefficient, while the jerk or surge which will necessarily arise from the power used, that of men rallying or jerking at the bars of the capstan, cannot fail to break the iron. The complement of men on board a man-of-war, is always sufficient, under ordinary circumstances, to purchase or raise the anchor by a capstan of the most simple construction, and thence increase of power, or what may be termed the means of dispensing with a number of men, is not a consideration; for it should ever be remembered that no increase of power can take place, without a corresponding decrease of velocity in the weight raised; or, that if 40 men were required to raise the anchor by the capstan when under the old form—that of the simple wheel and axle, and that by mechanical contrivances being attached to the capstan, 20 men were enabled to do the same work, then the 20 men would have to move the improved capstan round twice as fast as the 40 men moved the old capstan round, or otherwise they would be twice as long about it.

References to Plate 10, of the Capstan, p. 186.

Fig. 1.—Elevation of a double capstan or of such as are usually fitted to frigates and line-of-battle ships of the navy. It shows in perspective the whole machine; in frigates the upper barrel comes on the quarter deck, the lower barrel being on the upper deck, on which the hawse holes also are placed. In the line-of-battle ships the lower barrel is on the lower deck and the upper barrel on the upper deck or middle deck, according as the ship is one with two or three tiers of guns, all fore and aft of her.

- A A A, Iron spindle extending from upper point A to the lower point marked A'. This spindle should be well forged, and should be of the best materials, the whole strength of the capstan depending thereon; it is also placed in a turning lathe, by which the cylindrical form requisite to make it work accurately is ensured.
- B, Hoop and plate on the tenon of the upper barrel, by means of which the barrel is united to the spindle A at the upper part.
- C, A similar plate and hoop for security of the lower end of the upper barrel of the capstan.
- D, Hoop in the partners of the upper deck working in a metal bush or socket, thus forming a support for the spindle A to work in through the partners or deck.

- x**, Drop pauls or pins to connect the upper and lower capstans; and here some explanation is required, which is this: that the spindle **A** passes through the lower capstan without being united to it, or, in other words, the lower capstan has free play or movement round it.
- f**, Upper connecting plate, which is strongly secured to the spindle **A**.
- g**, Lower connecting plate, which is let firmly into the trundle head **h**; in **f** and **g** corresponding holes are made to receive the drop pauls (**x**). To attach the lower capstan to the upper one, or to the spindle **A**, the drop pauls, **x**, are let down through the corresponding holes for their reception in the connecting plates **f** and **g**, by which the trundle head of the lower capstan, and thence the barrel of it, is made one mass with the upper capstan. This power of connecting and disconnecting the two barrels or capstans gives the facility of using the capstans at one and the same time for separate purposes—the one of heaving the cable in, and the other to raise the lower yards or the top-masts.
- i**, Paul head; receiving the pauls or stops to prevent the recoil of the capstan.
- e**, A paul or shore of iron swivelling on a bolt, which is shown up or in the position in which it is placed when not required for use.
- r**, The same paul or a similar one, down and in use—the lower end being dropped into the paul rim **v** against a stop formed in it.
- v**, Paul rim or racket, let down into the lower partners and bolted firmly to them; indeed on the security of this rim the safety of the men at the bars mainly depends, and care should be taken in fitting it. The plan section of the paul rim is described by fig. 2.
- l**, Metal step or socket for the lower end of the spindle **A** to work in.
- n**, Collars or stops on the spindle **A**; the upper one is necessary to keep the capstan from rising, which it would prevent by its coming in contact with the underside of the partners at **D**; the lower collar prevents the lower capstan, when used separately from the upper, from rising by its forming a stop to the upper connecting plate **f**, should the lower capstan be forced up while in use.
- o**, The whelps or ribs of the capstan; they are formed in a curve to give the surge which is required to prevent the turns of the messenger on the barrel of the capstan from rising too far up them.
- p**, Cheeks placed between the whelps to steady them.
- w**, Holes to receive the bars which work the capstan; to secure these bars when shipped or in place, holes are bored down through the head of the capstan and through the bars, and pins are placed in them, and in addition the outer ends of the bars have a rope wound round them to join them all together, and the latter is termed swiftling the bars.

Fig. 4.—Section of a capstan bar, not on scale. The number and length required to each rate or class of ship of war are subjoined :—

Rate of Ship by the number of Guns.	No. of Bars.	Length of Bar.
		ft. in.
From 10 to 14 guns	8	8 6
From 16 to 18 „	10	9 0
Corvette of 800 tons measurement	10	9 6
Ship of 28 guns	10	10 0
„ 36 to 52 guns.....	12	11 6
„ 74 guns	14	12 6
„ 80 „	14	13 0
„ 100 to 110 guns	14	13 6
„ 120 guns	14	14 0

Plan and Section of a Capstan fitted by Brown, of London, for the use of the Chain Cable without the intervention of a Messenger, vide Sections, p. 137.

- a*, The upper capstan fitted as formerly described.
- b*, Elevation of the lower capstan with fittings at the lower part of it formed of iron, the ribs, *g* and *g*, in it acting like teeth or sprockets to clasp the cable, similarly to the sprocket-wheel with studs, as shown, Plate 10, fig. 3, of the common capstan, when a messenger is used.
- c*, Elevation of a friction roller, round which the cable is wound as shown on the plan, four being used as marked, *e*.
- d*, Of the plan shows the compressor for stoppering the cable.
- A*, The cable leading the hawse hole. The method of bringing the cable to the capstan may be traced on the plan; the links shown in dotted lines being those in contact with the ribs (*g g*) of the elevation.

The merits of this plan consist in not requiring the intervention of a messenger, whereby the hands required for passing the nippers, which unite the cable and messenger when a messenger is used, are saved; but this method makes it necessary that the cable locker, or compartment for the reception of the chain cable, should be immediately below the position of the capstan; an arrangement that is not always convenient in a man-of-war.

The windlass used in small vessels is a capstan, with the barrel worked horizontally, the power being applied by levers, which are shipped or worked in holes similar to those in the capstan head.

PART XXIV.

Rudder, its Action.—Efficient Angle to the Fore and Aft Line of the Vessel.—**Round-headed Rudders, when and where first introduced.**—Advantages arising from the Use of them.—Round-headed Rudder, from its conversion, subject to weakness.—References to Plate 9.—Wood-lock of the Rudder described.—Rudder Pendants, and their Use.—Temporary Rudders in Her Majesty's Navy.

DESCRIPTION OF PLATE 9,

And reference to the several portions of a Rudder when fitted with a round Head, or that the part in which the Tillar is fixed is circular; the Hangings of the Rudder being those introduced into Her Majesty's Service under a Patent taken out by Capt. Lehon, of the Royal Navy.

THE rudder, it should first be premised, governs the movements of the ship—the tillar by which the rudder is moved on its hinges or pintles being forced in ordinary cases the opposite way to which the head of the ship is required to be moved; this action of the tillar places the rudder itself across the line of water passing along the bottom of the ship, and the water, impinging on the rudder, forces the stern of the vessel, and consequently her bow, to pivot round a centre of motion. Theory has demonstrated that the rudder, for efficiency in turning the ship round, should never be forced over by the tillar beyond the angle of 42° from a fore and aft line, and experience or practice has confirmed this theoretical result; and it will be found that, in Her Majesty's service, arrangements are made (that will presently be pointed out) to prevent the rudder being forced over beyond that limit. Round-headed rudders, which with their fittings are now to be described, were first introduced into the ships forming the mercantile navy of the East India Company. The advantage arising from this form of rudder and mode of hanging it is this, that the hole through the counter or stern of the ship which is called the helm port, is wholly closed up by the head of the rudder passing through it, with almost a close joint, as the line of the centre of the pintles or hinges is made to pass through the centre of the rudder head, whereby the round head of the rudder becomes a large pintle or hinge working in the counter or helm port. On the old system of square rudder heads, the line of the centre of pintles was the half diameter of the pintle before the fore side of the rudder head, and the rudder, necessarily working on the centre of the pintles, required that the hole through the counter of the ship for the reception of the head of the rudder should be made large enough to allow of the rudder working over with a radius equivalent to the diameter of the rudder head; the large helm port which was thence formed was found to be the source of leakage in the ship at all times, and, in the event of the loss of rudder at sea, the large aperture endangered the safety of the vessel.

The new plan, or the use of the round-headed rudder, is not however without objections—as the upper pintle or hinge (without great precaution is used in the conversion of the main pieces of the rudder), when let on or into its place, cuts so far into the main piece which also forms the round head, as seriously to injure the strength of it; and with the long head above this pintle, which was in the first instance unsupported, the rudder head was wrung off, in some instances at or below the upper pintle. This difficulty has been met in practice by the upper part of the rudder head itself being made to work in a collar formed on the deck nearest to where the tillar works, the head of the rudder thus becoming the upper pintle, and the one on which the greatest strain is brought when the rudder is in action; the former pintle, which under such a provision is then the second, being acted on like the others below, serves only as an hinge on which the rudder turns.

*Scales used in the Figures. Figs. 1, 2, 4, 5, 1½ inch to a foot;
Fig. 3, ¼ of an inch to a foot.*

References to Plate 9, of the Rudder.

- a*, Fig. 3.—Long rudder head made round, or what is termed circular.
- a b*, The whole length of the main piece, shown extending the entire length of the rudder; it is usual in large ships to let the main piece run down below the second pintle, the lower part being made good by a lengthening piece. The main piece is usually of oak.
- c*, A piece of elm worked as shown, to give the form of the rudder on the fore side, and prevent the main piece (*a b*) from being injured by the letting on the pintles (*d*).
- e* and *f*, Usually pieces of fir to make up the form of the rudder.
- g*, The braces or gudgeons, fixed to the stern post and bottom of the ship to receive the pintles. The pintles and braces are bolted and screwed through the arms of them, respectively to the rudder and post.

At the lower part of the rudder, or what is termed the heel of it, a sole piece is worked, being a piece of plank usually 6 inches thick at the ends of the pieces, *c b*, *e*, and *f*; should the ship take the ground lightly, this sole piece, by acting to the rudder like the false keel to the vessel, would easily come off, and perhaps free the ship from danger.

The sections of the rudder and post, marked *i* and *k* in the plate (fig. 1), show the angle or bearding taken off from the post and the rudder, to allow the rudder to work over each way through an angle of 42° before the fore side of it will come against the aft side of the main post; this is the preventative alluded to in a former paragraph. The other sections (fig. 4) are those of the pintles (*d*) and braces (*g*) upon a larger scale, showing at *l* and *m* the crowns of the pintle and brace of one set. The intention of the crowns is to ensure the pivots or pintles working more truly on each other.

c, k, Figs. 5 and 6,—Are enlarged sections of the pin that is fixed in the pintle (*d*, fig. 3), and great care should be taken in letting on the braces to the bottom of the ship, and the pintles to the rudder, that they may work with each other as one joint: as an efficient and easy way to accomplish this end, it is suggested that a long rod of wood be employed of the same diameter as the pintle *d* or *k*, and that this rod be secured up and down the stern post with its centre in the position that will be finally occupied by the centre of the pintles—then each brace being threaded on this rod, and let on to the bottom from it, will give the positions of the braces correctly, while a line got on the rudder for the centre of pintles, will be equally as effective in fixing the pintles.

There is also fitted to the rudder what is called a woodlock, which is a piece of wood placed in a score, cut out of the rudder under the brace which receives the pintle that is immediately below the water line of the ship when loaded; this woodlock is made to have its upper end bearing against the under side of the brace, and the lower end against the score in the rudder; by which means, the rudder is prevented from rising or being unhung by a slight concussion. The woodlock is usually nailed in its place. There is also usually a bolt in the rudder placed just above water in the back of it, for the reception of what are termed rudder chains; which are metal links for a short distance shackled to the bolt alluded to, the other parts being made up of rope pendants, which are fastened round the stern and led to the quarters, where they are firmly secured to bolts driven to receive them; the use of the rudder pendants is, to prevent the loss of the rudder, should it be unshipped at sea by any casualty.

The practice is to fit temporary rudders to Her Majesty's ships, but a description of them would be foreign to this work.

PART XXV.

Remarks on the Application of Steam to the Propulsion of Ships; first, when used as a Prime Mover; secondly, when applied as an Auxillary to the Sails.—Description of Plate 11, or references to the Elevation, Plan, and Section of a Paddle-box of a Steam-boat.—Modes of putting the Boat into the Water, and taking it out.—References to Plate 12, or a descriptive Sketch of the Aperture for the Screw Propeller.—Mode of raising the Propeller adverted to.—Danger that would arise from a Vessel propelled by the Screw touching the Ground.

WITHIN the period of the last twenty years, a great revolution has taken place both in the armed and commercial navies of this country, and perhaps the more especially so in the first—the British Navy. The application of steam to the propulsion of ships through the water, has converted the track-

less regions of the ocean as it were into evanescent railroads, whereby the fickle and uncertain winds are disarmed of their powers of delay, by man having a power placed in his hands, by which he can with ease dispel the listlessness of the calm, or render nearly nugatory the adverse storm—when either tend to check the progress of the vessel. It would be far from the immediate province of a rudimentary work on ship building, and more particularly so in one treating on the practice of that art, to attempt to point out the rise and progress of steam as applied to the navigation of the sea; suffice it then to say, that although Dr. Lardner at the early stage of its application pronounced that it was impossible for vessels to pass the broad barrier of the Atlantic Ocean by the power of steam, the learned doctor lived long enough, to take advantage of the triumph of man's ingenuity and indomitable perseverance by personally witnessing the passage to America made by steam vessels, as nearly certain as to the time of arrival in port as that of the mail coach at the inn on shore, and to hear that the world had been circumscribed by the same description of locomotive machines. The building of the hull of the steam vessel for war is accomplished by the same process as that which has been described for the sailing ships of the navy, and the fore and after parts of the one assimilate to that of the other, and the same requirements are necessary in the internal arrangements of both classes of ships for the accommodation of the officers and crew, the stowage of the stores and provisions, and the reception of the equipments of a vessel designed for warlike purposes; but the centre portion of the vessel to be propelled by steam differs essentially from that of the sailing one, and may fairly be said to be an addition introduced between what would otherwise, when united, form a sailing ship; the engine-room, comprising the compartment that is required for boilers, engines, and coal bunkers, being a space that ought ever to be a blank in the internal capacity that may be considered due to the stowage of the ship's stores and equipments; or, in other words, that the body of the steam ship before and abaft the engine-room, should constitute the perfect man-of-war in all respects of stowage, as the engine-room should be looked upon merely as a receptacle for the internal power of locomotion.

Steam vessels have had two means applied to them for moving them through the water. The one of longest date, termed paddle-wheels, is in principle of action similar to that of the railroad carriages of the land—the paddle floats of the one acting on the resisting medium of the water, aptly bearing comparison with the resisting medium caused by the friction of the carriage wheels on the rails of the other.

The other method of producing motion in a steam vessel is the screw propeller introduced by Mr. Smith, and it may with justice be styled a modification of the ancient and effective practice of sculling a boat with an oar; a process in the hands of an adept the most successful for obtaining speed in her.

The relative capabilities of these systems is certainly not within the limits of the descriptions that should be given in this work : the outline of the propelling actions (with steam as the prime mover) in the two is all, then, that will here be attempted.

Plate 11.

Elevation, Plan, and Section of a Paddle-Box of a Steam Boat, showing the arrangements made by Davits for throwing into the water, or raising from it, the Paddle-Box Boats.

ELEVATION.

PLAN.

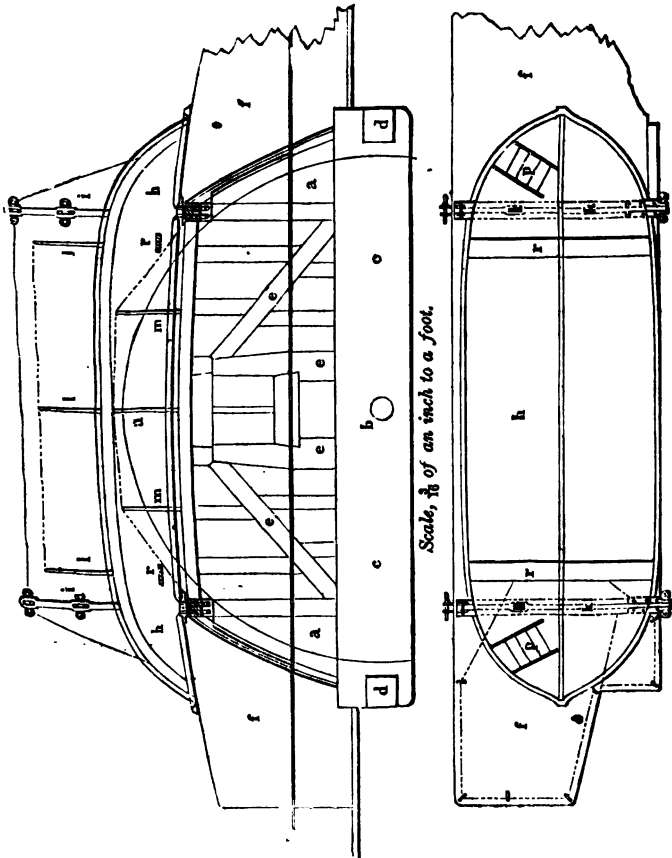

H .

Description of Plate 11, illustrative of the Propelling Action of Steam when applied under the form of Paddle-Wheels to Vessels; showing also the arrangements which are made that the upper part of the Paddle-Box, or Covers to the Paddle-Wheels, may be formed by Boats termed Paddle-Box Boats, and including Sections depicting one of the methods by which these Boats, when required, are placed in the water or raised from it.

The form and action of the paddle-wheel of a steam boat are so well known to most men of our sea-girt isle, that little is required to be written to point out the principle on which they act. Under this impression it only remains to give to those who have never traversed the water by the aid of steam, the idea of associating the action of the water or tide mill of the inland stream with that of the paddle-wheel of the steam boat. In the first, the water by flowing against the wheel gives motion to it, which again by machinery communicates the same to the stones that grind the corn; while in the second case (the ship), the power of steam within board communicates rotatory motion to the paddle-wheels partly immersed in the water, causing a resistance to arise from the water against the floats of the wheel that produces motion in the vessel.

References to the Plan, Section, and Elevation of the Paddle-Box of a Steam Vessel.

- a*, In the elevation, denotes the extreme edge or extension of the paddle floats or boards, one of which boards are pointed out in the section by the corresponding initial letter *a*, where the surface of them is given. These floats vary in thickness, length, and breadth, according to the peculiar views of the maker of the engines. Observe that the surface they should present to the water depends on the relation that the power of the engines bears to the weight and form of the ship. Too large an amount of resistance, produced by an excess of surface in the paddle floats, would produce over work for the engine; while too little surface could not fail to allow of the wheel revolving without forcing the vessel ahead; in other words, there is a certain immersion of the float of the wheel, surface of float, and revolutions of paddle-wheel per minute, which will give the maximum velocity to the ship.
- b*, In the elevation, is descriptive of the size of the end of the paddle shaft, which is shown on the section extending from the side of the ship to the spring beam (*c*). In these later days of steam power the spring beams (*c*) have been dispensed with, the shaft (*b*) revolving on a chock secured to the side of the ship, instead of the outer end being borne on the plummer block attached to the spring beam (*c*). The lines marked *o* in the section are representations of the radii of the wheel to which the paddle floats are attached, as shown at *a* of the same figure.

SECTION.

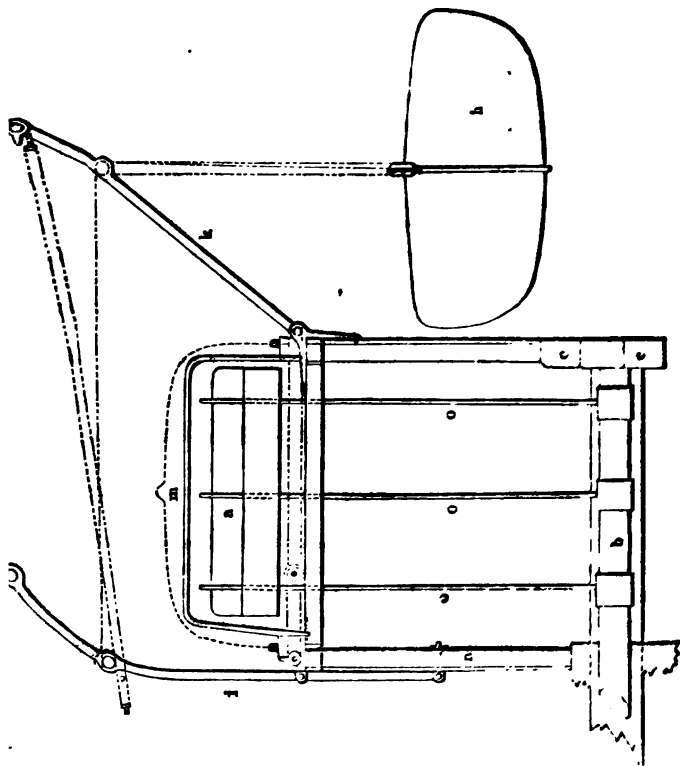
Scale, $\frac{1}{2}$ of an inch to a foot.

c, Of elevation, the spring beam placed fore and aft or lengthways of the vessel on the ends of the paddle beams (*d*); the spring beam supports the plummer block or gudgeon, which receives the outer end of the shaft (*b*), and forms also a base for the reception of the frame work (*e*) of elevation, which is part of the bed necessary for the paddle-box boat.

d, Of elevation, the ends of the paddle beams through the spring beams (*c*).

e, Of elevation. Truss framing, to form the paddle-boxes, the lower portion of which is birthed, or covered in with boards, the upper part being formed into gratings or lattice-work for the escape of the air.

- f*, Of elevation, technically termed paddle walks, being an extension of the paddle-boxes, to receive the ends of the paddle-box boats, and the under parts forward and aft, marked *f*, to be available for washing houses, galley, colour or flag lockers, &c.
- A*, In all threes of the figs., is descriptive of the paddle-box boat. In the elevation it describes the boat as being placed with the bottom of her upwards, forming the top of the paddle-box. In the plan the breadth of the boat is seen, and the space (*A*) in which the paddles work; while in the section *A* shows the boat slung by the davits *k* and *i*, as being ready either for being lowered into the water or hoisted on board; the ropes or falls are denoted by ticked black lines.
- i*, In the elevation and section, inner davit of paddle-box of iron.
- k*, In plan and section the outer davit of paddle-box. In the plan, the boat is shown laying on it, being in place; and in the section, the boat has been turned over and out by the outer davit (*k*) having been raised by means of the crooked arm of the inner davit (*i*).
- l*, Of the elevation, stantions for man ropes temporarily fixed to the keel of the paddle-box boat; the man ropes forming a safety to the crew while passing over the boats.
- m*, Both in elevation and plan, illustrative of guard irons to prevent the boat's bottom from being forced by accident into the wheels.
- p*, In the plan, ladders to afford facility to the crew in ascending the paddle-box boat.
- r*, Of plan and elevation, points out the positions of the fore and after thwarts of the paddle-box boats, or the fixed seats for the rowers of them.

Another plan for a pair of single straight davits has of late years been adopted in Her Majesty's service for this evolution; it is said to be more simple in its operation, which is doubtful, but the method is certainly much less expensive to fit.

REFERENCES TO PLATE 12.

The aperture for the propeller is cut in the run of the vessel, or in what is termed the after deadwood of the ship. To effect this two stern posts have been introduced, the fore one called the body post, or what might be with more propriety termed the abutment of the after deadwood, and the after one called the rudder post. In fact, a hole or aperture (*b*) is required for the screw or propeller to work in, and the body post, as it is named, makes the fore side of such aperture. The shaft (*c*) runs through the body post in a water-tight stuffing box, and the propeller is turned

rapidly round in the aperture (*b*) by means of a long shaft connected with the steam-engine amidships.

a, Shows the rudder post or the foundation to which the rudder is hung.

The other part of the plate shows a frame-work and section of an apparatus that is fixed for raising the propeller out of water, when the vessel is required to make use of her sails, independently of the auxiliary power of steam; there is a trunk formed above the aperture (*b*) up to the weather deck, that the propeller may, when it is requisite, be lifted out of the water and put on it. The apparatus usually fitted will only raise the propeller out of the water, leaving the other part, that of placing it on the deck, to be done by the sailor with tackles. It is much to be doubted whether the use of the tackles throughout would not be the most economical mode of effecting the operation.

The screw propeller and its fittings have yet to be tested, under the trial of a lee shore and the touch of the heel of the post on a rock—a reference to the plate will point out the defenceless state of the after part of the vessel under such a misfortune; but such things as striking abaft have occurred to sailing vessels that have escaped with trifling injuries; should the same evil overtake the vessel propelled by screw, it is to be feared that the loss of a rudder and the plank of the bottom wrenched out by the shaft of the engine, would render the same accident fatal to the ship and crew.

PART XXVI.

References to Sketch 13, descriptive of some of the Ordnance employed for Naval Purposes, and of the Fittings for their Use.—Weight of Powder in Shells.—Number of Shells for close Action.—Table of Powder supplied for each rate of Ship in Her Majesty's Navy.

THE largest guns that were used on board Her Majesty's ships during the last war, if those in Her Majesty's ship *Glatton*, which carried 68 lb. shots, be excepted, did not exceed in length 9 feet 6 inches, and 56 cwt. in weight, carrying a shot of $6\frac{1}{2}$ inches in diameter, weighing 32 lbs. Guns of that calibre formed the lower tier of armament of line-of-battle ships, or of those ships which had two or three ranges of artillery. In the present day the guns employed in the sea service have been increased in weight up to 100 cwt., and in length to 10 feet 6 inches, carrying a shot of 10 inches in diameter, and of 84 lbs. in weight. These have hitherto been employed principally for pivot guns in steam

vessels, but the probable effect that such guns when used in steam vessels would have on line-of-battle ships in a calm, has led to the contemplated introduction of these large guns on the poops of sailing ships now building; doubts, however, have been entertained whether the crews of the steam vessel or line-of-battle ship, could efficiently handle such heavy missiles as the shots of such guns, in even moderate weather: and both shot and guns would certainly be equally uncontrollable in really bad or tempestuous weather.

Port of the Lower Deck, fitted to receive the common 32-pounder long Guns on common Carriages.

Weight of gun	56 cwt.
Length of gun	9 ft. 6 in.
Weight of carriage	9 cwt.
Ports { Wide, or fore and aft.	3 ft. 6 in.
{ Deep	2 ft. 11 in.
Centre of metal to be from 8 ft. to 8 ft. 4 in. above the deck,	
Height of lower port cill from deck, 2 ft. 4 in.	

Fig. 1 is descriptive of the front elevation of the port, with the relative positions of the several eye bolts and ring bolts required for the manœuvring and fighting of the guns. An eye bolt is a bolt stave of round iron cut off to the length required to go through the side of the ship shown by fig. 2, and to have an eye formed in it of $2\frac{1}{2}$ times the diameter of the iron used to make the bolt. Thus, an eye bolt of 1 inch diameter would have an eye in the clear of $2\frac{1}{2}$ inches. A ring bolt is the forming a ring in the eye of the bolt above described, the diameter of such being in the clear 5 times the size or diameter of the iron of the bolt, or, assuming an inch bolt, it would be 5 inches. The eye bolts, when used in gunnery, are to receive the hooks of the tackles by which the guns are trained or pointed, or run out, and the ring bolts receive the breechings of the guns, which are strong ropes led round the breech of the gun to overcome the recoil of it when it is fired.

- a a*, Fig. 1.—Eye bolts in the shelf of the upper deck, called muzzle lashing bolts. The muzzle of the gun, or *k* of fig. 2, in bad weather, is placed against the shelf between them, and strong lashing passed round it, and through the eye bolts (*a a*). Bolts $\frac{1}{2}$ inch in diameter.
- b*, Eye bolts for the train tackles or pulleys, by means of which the gun is made to point with its muzzle (*k*) forward, aft, or amidships. These tackles are also used to run the gun out after it has been loaded. Bolts $\frac{1}{2}$ inch in diameter.

Sketch 13.

Fig. 1.—Lower Deck Port.

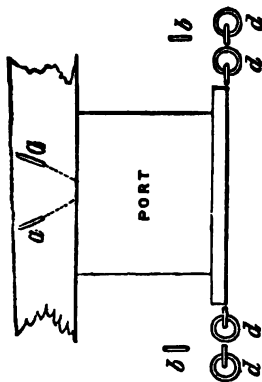
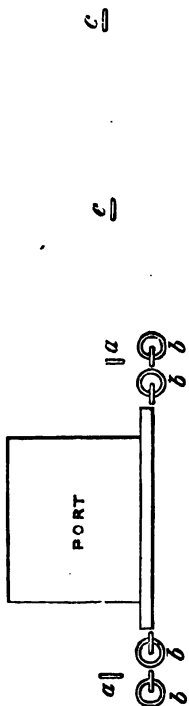

Fig. 3.—Quarter Deck and Forecastle Carronade Port.



DECK

c, Eye bolts placed between the ports for extreme training of the muzzle of the gun as far forward or aft as the side will admit.

d d, Breeching and preventer breeching bolts; the first from the side of the port receives the breeching or rope security (*g*, fig. 2), used to restrain the recoil of the gun; the other is called a preventer bolt, being intended as a resource in the event of the breeching bolt being disabled. Iron for bolts from $1\frac{1}{4}$ inch to $1\frac{3}{8}$ inch in diameter.

Fig. 2.—Section of the side of the ship, showing the thickness of timber and plank, also deck and beam. The gun and carriage are also shown sectionally.

e, Chamber of the gun, or receptacle for the powder.

f, Trunnion or axle of gun. The upper side of *f*, or trunnion, is usually in the line of the centre of metal or centre line of the gun.

g, Breeching, made of the best white rope, secured to the ship's side through the bolts (*d, d*) of fig. 1, and passing through the breeching ring (*g*) of fig. 2.

h, Carriage of wood, weighing 9 cwt.

i, Wooden wheels to facilitate the movements of the guns; they are called trucks, and distinguished by being called fore and hinder trucks.

k, Muzzle of the gun, or the portion of the gun at which the aperture is made, which receives the powder and shot. These guns, of 32-pounds calibre, have now a portion of the 80 rounds of shot formerly supplied for each gun made up of filled shells of the same diameter as the shot, viz., $6\frac{1}{2}$ inches.

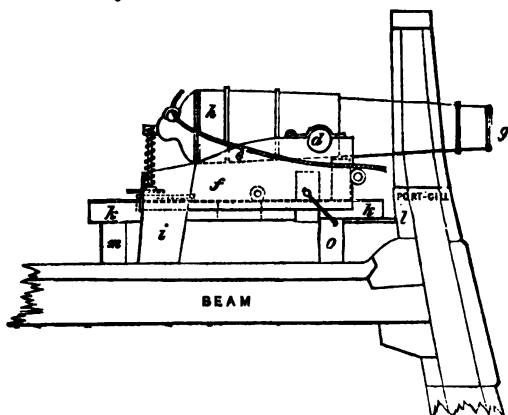
Fig. 4.—Section of the Port and Carronade.

species of guns having been suggested at and cast by the iron foundry at Carron. Length of gun, 5 feet 6 inches; weight of gun, 25 cwt.; weight of carriage and slide, 5 cwt.; height of cill from deck, 1 foot 10 inches.

a, Train tackle eye bolts.

b b, Breeching bolts as described for the long guns.

c, Eye bolts for extreme training of the guns, $\frac{1}{8}$ inch in diameter.

Fig. 4.—Elevation of the side of the ship and gun on the carriage. Weight of the carronade, 25 cwt.

d, Trunnion of the carronade or axle of motion for depression or elevation.

e, Breeching or rope to restrain the recoil.

f, Carriage of the carronade designed by the late Sir Thos. Hardy, being a carriage for the gun, with an inner leg (*i*), travelling over a slide (*k*) which slide is pivoted to the plate (*l*), securely bolted to the side of the ship; the carriage (*f*) is so constructed as to admit of its being squeezed or compressed down on the slide (*k*), which produces a friction that takes off part of the recoil of the carronade from the breeching (*e*).

g, Muzzle of the carronade to receive the powder and shot.

m, Inner wood chock to slide (*k*), to keep it the required height from the deck.

o, Outer wood chock to slide, for the same purpose.

Rounds supplied of filled Cartridges for each Carronade of 25 cwt.

	Full.	Reduced.
	50 No.	30 No.
Charges of powder . .	4 lbs. 0 oz.	2 lbs. 8 oz.
No. in each powder case	25	40

TABLE OF THE POWDER SUPPLIED TO THE SEVERAL RATES OF
HER MAJESTY'S NAVY.

Rate of the Ship.	Guns.	Number of Metal-Lined Cases.			Gross weight of Powder and Cases.		Charges of Powder.	11 distant range in a case. 16 full cartridges in a case. 20 reduced cartridges in a case for 32-pounders. Guns of 56 cwt. Rounds supplied per gun of filled cartridges. Distant, Full, Reduced, No. No. No. 20 20 40 } lbs. lbs. lbs. 10 8 6
		Whole Cases.	Half Cases.	Quarter Cases.	tons	cwt.		
1st rate of 120	636	40	3	33	0			
1st " 100	617	43	3	32	0			
2nd " 92	558	42	2	29	0			
2nd " 80	475	38	2	25	0			
3rd " 72	361	33	3	19	0			
4th " 50	312	24	1	16	0			
5th " 42	173	20	1	10	0			
5th " 36	215	19	0	11	0			
6th " 26	115	14	2	6	0			
Sloop of 18	54	12	2	3	0			
Brigantine 3	15	9	2	1	0			

PART XXVII.

Midship Section as linearly described in Plate 2.—References to the several Portions of it, as pointing out the relative Positions, by Sections, of the Timbers.—Planking, inside and out.—Beams and Decks.—Method employed if required to take off Ship when built.—References to Plate 4, as descriptive of the Methods which have been adopted in putting Beams together when they are composed of more than one piece.—References to a Sketch of the Deadwood of a large Frigate.—Method of making Floors in the rising Portion of the Ship's Frame.—Expansion of a common Frame of Timbers, and one composed of long and short-armed Floors.

THE delineated midship section of the draughtsman is a linear drawing, descriptive of the shape of the vessel both externally and internally, at the centre athwartship section of her; and on it is shown the view that would be presented to the eye of an observer, were a ship when built cut into two portions at the middle of her length. In the ship under such a division, the form of the timbers of the frame would be wholly and fully developed, or at least the moulded or shaped surfaces of them; but the sectional areas, or breadth and thickness, of each of the several strakes of plank, composing what are termed wales, diminishing plank, &c., would only be observable.

[It is true, however, that these would each be seen at their relative heights from the keel of the vessel, and at their relative breadths from the middle line of her; and thence on the draughtsman's paper will be found, on scale, a miniature picture of that portion of the vessel, and the relative heights and breadths of the several sections of the ship's wales, diminishing planks, &c., be depicted on it with great accuracy.]

On this plate is also given the disposition, or shift of butts, or ends of the timbers composing the frames, in the midship part of the ship—being a longitudinal view of the internal arrangements amidships of the frame or ribs of her. This view is a projection of the form of the vessel as to height, but descriptive of the length of that portion of her to a scale of measurement. This will be better understood by tracing the $\frac{1}{2}$ floor head of the section marked F H, to the $\frac{3}{4}$ floor head of the disposition of the frame. In the section the whole length and form of surface of the $\frac{1}{2}$ floor is shown; while, in the disposition, the same extent of timber is represented by the projected height of the floor head above the lower edge of the rabbet of the keel of the ship: the same will be correct for the relative positions in height of every other point in these pictures of part of a naval construction.

References to the Midship Section, Plate 2.

- A, The thickness of the several decks or platforms: vide Scheme of Scantlings.
- In small vessels the decks are named as follows:—Upper deck, lower deck, platforms. In a ship carrying 74 guns, or one of two decks, where the guns range fore and aft the vessel—poop, quarter-deck, waist and fore-castle, main deck, lower deck, orlop, platforms.
- B, The beams placed across the ship to receive the platforms or decks.
- C, Waterways to receive the decks and secure down the ends of the beams (B).
- D, Shelf pieces at the several decks (A), to receive the ends of the beams (B), and form part of the security of the beams to the side of the ship.
- E, Iron knees, to further connect the beam (B) to the sides of the ship, and thereby to unite the two sides of her firmly together. These knees, under this view of the carpentry of a ship, may be considered as an increase in the breadth of the shelf (D), the required size of iron being much less cumbersome than the wood of equal strength would be; the dotted lines through the side, and up and down to each of the knees E, are descriptive of the position of the bolts in the knees which form their security to the beam and side of the ship.
- F, Thick strakes of planks worked over the heads of the floor timbers and the heads of the 1st futtocks, to prevent the heads and heels of these timbers of the frame from being forced in. They are bolted or united to the

timbers and outside planking by the thorough fastening of the bottom plank.

- c, Limber strakes, to form a gutter leading to the pump well on each side of the keelson (π), that the water from leakage may, by draining down to it, pass freely through it to the pumps, which are placed in the immediate vicinity of the main mast.

The limber boards are shown by this section with one end on the keelson (π) and the other on the limber strake (a); these boards form a covering to the limbers, to keep them from being choked with dirt. Sometimes the limbers are covered by iron castings forming part of the ballast required in the ship.

- n, Keelson, or internal keel, to confine, in conjunction with the keel (κ), the floors of the frame of the ship in their places; the keelson bolts which pass through keelson, floor, and keel, are in a 1st-rate, or 120-gun ship, $1\frac{1}{2}$ inch in diameter.

- i, Fillings between the timbers of the frame, being less than the moulding of the timbers by the distance the dotted line is below the full line of the section of the timbers, forming a watercourse to the limbers.

- k, Section of the keel showing the rabbet for the reception of the plank of the bottom.

- l, Section of the false keel used to give depth of immersion to the vessel, and which, by its being slightly secured to the main keel, admits of being easily removed by a blow should the ship strike the ground.

- m, The rough tree rail forming the upper boundary of the timbers of the frame, as well as of the exterior and interior planking.

- n, Wales or thickest planking used exteriorly.

- o, Iron riders, shown in the disposition of the frame. The thickness and breadth of them used in the several rates of ships are given in the scheme of scantlings; they are sometimes let into the timbers of the frame their whole thickness, at other times half the thickness; and the system has been adopted by some practical builders of bringing them to the timbers without letting them in at all. The question hinges on this: Which is the best for the strength of the ship—to score into the timbers only; to score or notch into the timbers and internal planking equally; or to take the whole scoring out of the internal planking?

- p, The bearers of the boilers of a steam vessel placed on this section from want of space in this small work. They are worked the length of the engine-room and 10 feet beyond at each end; they receive the boilers or large kettles and the engines, and form to the steam vessel the sister keelsons of sailing ships.

- r, Of the disposition, shows the openings between the timbers of the frame marked by the shaded lines. These openings, as before remarked, should

be equalized all the way up the frame to the highest point at the rough tree rail (m); the dotted lines show the height of decks.

The sections of the thickness and breadth of each portion of the wales, diminishing plank, and plank of the bottom, are shown by the shading lines in the section.

A SHORT STATEMENT DESCRIPTIVE OF THE METHOD USED IN TAKING THE FORM OF A SHIP, WHEN BUILT.

The circumstance of many ships during the last war being captured from the enemy, of whose form no draught or drawing was in the possession of the captors, and their good sailing qualities being such as to make them a desirable guide for English naval construction, it was the practice to have such vessels placed in a dry dock (Plate to Dock), and their forms taken off by a draughtsman, and a drawing upon the usual scale made of them. The outline of the method pursued is shown, attached to the midship section of Plate 2; and, as the process for one section would nearly carry the novice through the whole operation, the description of the one section being taken must suffice.

A base board (q), or board having the numeral feet marked on it, is placed against the side of the keel (k), this base board, q of the figure, being set by a spirit-level to the horizon, and square to the keel by a large square, placed with one of its arms against the side of the keel, and the base board q , being kept to the other. Another board (R q) is then fixed perpendicularly to this, as shown in the section, having also the graduated scale of feet marked on it. The distances at every 2 feet from these standards of measurement are then taken on the plumb or perpendicular, and the level or horizontal (as shown on the figure by the dotted lines) to where they meet the body of the ship or the wales, diminishing plank, bottom, &c.; these distances are registered in feet and inches, and set off on paper to the scale chosen for the drawing, when the form of the section cannot fail to be accurately depicted.

The perpendiculars, marked P in the section, form the boundary lines of the greatest transverse section or midship section, and thence inclose all other sections taken under the same system. It is a tedious operation, but it was thought necessary at one period to do it for every new vessel in Her Majesty's service, after being coppered, that her form might be the more accurately obtained for ascertaining her light displacement or weight of hull; but surely the drawing by which the vessel was built could not, in the government service, be so much deviated from in building, as to make this operation necessary for detecting what would be, at the utmost, the immersion of one inch, and thence the custom has fallen into disuse, as a form of office to be more honoured in the breach than in the observance.

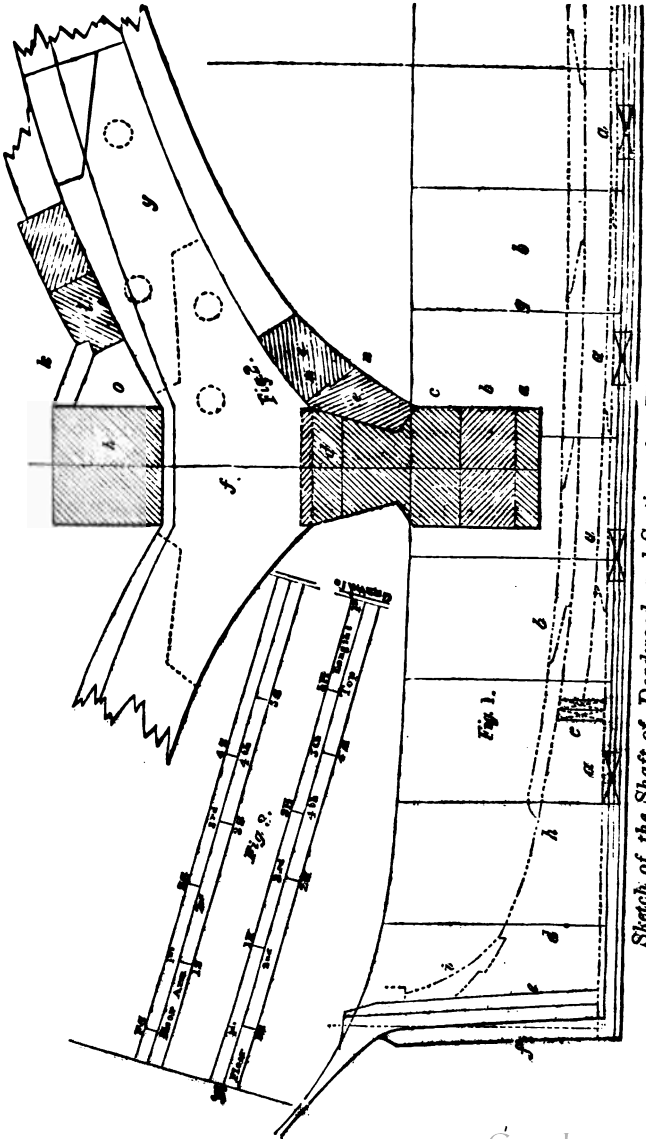

Sketch of the Shaft of Deadwood, and Section of a Floor on a larger scale.

REFERENCES TO PLATE 4 OF BEAMS.

The beams should, where practicable, be in one length, to avoid the expense of workmanship, and to insure strength. In large ships they cannot be obtained in one, and hence necessity suggested the arrangements described in the plate.

Fig. 1.—The beam as usually put together, when the store of timber will allow of its being provided in two pieces; it is then technically termed a two-piece beam. The dowels employed to connect the scarph are marked thus (o), the bolts (·); and of the two views shown of the beam, the upper one is a side one, or moulded, and the lower the sided, and shows the scarph or overlap of the two pieces, as seen on the upper part of the beam; the scarph is usually $\frac{1}{3}$ rd the whole length of the beam.

Fig. 2.—In large ships, to obtain the beams, recourse is had to forming the beams of three pieces, of which fig. 2 is a descriptive drawing. The bolts and dowels are shown as described for fig. 1, and the scarph is usually $\frac{1}{4}$ th the length of the beam.

Fig. 3.—Descriptive of the moulded and sided views of a beam on the plan suggested by Mr. William Edye, Master Shipwright of Devonport Yard; it is a modification of the key scarph of the joiner of very ancient date. The iron keys, which are shown in the sided way by the square □, are tapered to form wedges. The lips of the scarphs, or the extreme ends of each overlapping part, are shown wrong in the figure; they should have been drawn square to the moulded edge of the beam. This beam is secured in its scarph by bolts marked (·), and the tree nails marked ×. The scarphs of Mr. Edye's beams run in lengths from 8 feet to 8 feet 6 inches in the beams of a line-of-battle ship.

Fig. 4.—A modification of Mr. Edye's beam, having only one key to it. This method of scarphing was introduced by the Committee of References instituted by the Admiralty in 1846.

Fig. 5.—A beam suggested by Mr. Lang; it is bolted and coaked in a similar manner to that described for fig. 1: the lip being let in with a dovetail 7 is the characteristic of this plan.

References to the Sketch of a Shaft of Deadwood for the After Body of a large Frigate.

Fig. 1 Is a drawing made by the draughtsman, to show the relative positions of the masts of the ship, the scarphs of the keel, those of the keelson, and the distance to which the floors or lower timbers that cross the keel are extended (see description of Cant Bodies) from the midship part of the vessel each way.

- a*, Scarphs of the keel; the number of the scarphs, or the lengths of the several pieces the keel is composed of, being determined by the store of timber.
- b*, Scarphs of the keelson, which should come between those of the keel and have two bolts passing through them (vide description of the Keelson).
- c*, After square floor, abaft which the lower timbers of the frame, or those called the double and lower futtocks of the cant body, take their heeling or abutment against the deadwood (*d*); some practical builders employ cant floors, but the difficulty which is found in obtaining the after square floors, will deter the economical shipwright from attempting a combination that yields but little probable advantage, at great and positive expense.
- d*, Deadwood, to form the fine after-portion of the ship's body, and serve as a foundation to fix the heels of the after timbers of the frame against. It should never be converted from over-grown timber, which would be liable to early decay, from the difficulty in removing it for repair.
- a c*, Is descriptive of the overlap of the after piece of keelson (*b*) over the deadwood (*d*), by which means, when the keelson bolts are driven, which pass through keelson, deadwood, and keel, the after deadwood is connected thereby with the floors of the ship, and the joint at *c*, or where the deadwood comes against the aft side of the floor (*c*), is succoured.
- e*, Inner post of the ship into which the after ends of the deadwood (*d*) are tenoned.
- f*, Main post of the ship.
- g*, Stations of the sheer drawing of the ship, or the room and space for the timbers in her.
- i*, Sternson, or a knee to connect the after end of the deadwood (*d*) with the inner (*e*) and main posts (*f*) of the ship, large bolts being driven through them in a fore and aft direction.

Fig. 2.—A section on an enlarged scale descriptive of the method adopted when the V like form of the ship foreward and aft causes the floor timbers which cross the keel not easily to be obtained.

- f*, Shows the short chock crossing the keel with scarphs to receive the heels of the 1st futtocks, as depicted by the dotted lines of the fig.; the dowels are also delineated that connect the chock to the half floor of the frame. The loose tie which is shown by this method, but which necessity renders imperative when the floors are carried aft or forward beyond a certain limit, will illustrate what was adverted to in the description of fig. 1 of this woodcut.

a, Lower false keel.

b, Upper false keel.

c, Main keel.

d, Rising wood, to form the body and receive the scoring of the floor; the

conversion of the floors is rendered easier if the throating of them is diminished by increasing the rising wood (*d*).

- e*, Thick garboard strakes rabbeted over each other to make the seam for caulking (*m n*) the same as the thickness of the bottom plank.
- f*, Floor or chock.
- g*, Half floor butting at the middle line of the ship.
- h*, Keelson or inner keel of the ship, forming with the keel (*c*) the fore and aft connection of the floors (*f*).
- k*, Limber boards.
- l*, Limber strakes.
- o*, Limber or passage for the water to the pumps.

Fig. 3.—An expansion of two consecutive frames of the ship, when the common system of floor and 1st futtocks meeting at the middle line of the ship is conjoined with an alternate frame composed of long and short armed timbers crossing the keel, or where on one side, the timber crosses the keel to the floor sirmark marked *F s*, and the other end of the same timbers lengthens to the first sirmark of the common frame marked *F s*, or the heads and heels of each alternate frame of the ship are by this arrangement brought in a line with the sirmarks of the common shift of timber, which makes three timbers between each head and heel or joint, but a very short shift or scarp. The plan has been pointed out under the head of Framing the Ship.

PART XXVIII.

Description of the Method employed to remove Slack Ropes in the Tillar of Her Majesty's Ship North Star.—References to the Elevation and Plan of the Sketch, describing the Method of reaving and fixing the Tillar Ropes.—Eye Bolts for relieving Tackles; where placed.

REFERENCES TO THE ELEVATION OF THE SKETCH.

- A*, Section of the head of the rudder with the tillar inserted in it.
- B*, Tillar of wood. Formerly all tillars were made of wood, and they were of greater length than now.
- C*, Steering wheel, composed of a barrel and spokes inserted into the ends of it, the outer ends of such spokes forming handles for the man stationed at the helm to take hold of in steering the ship.
- D*, Wheel stanchions or supporters of the axles on which the wheel (*c*) travels.
- E*, Extreme end of the spoke of the wheel (*o*), being the place where the helmsman places his hands to steer.

Sketch of the Steering Wheel of Her Majesty's Ship, North Star.

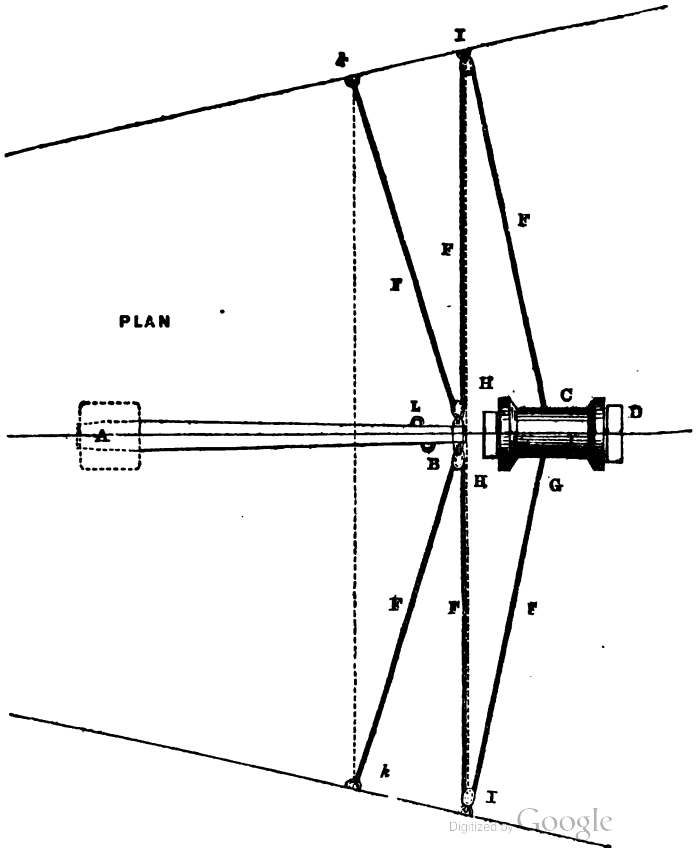
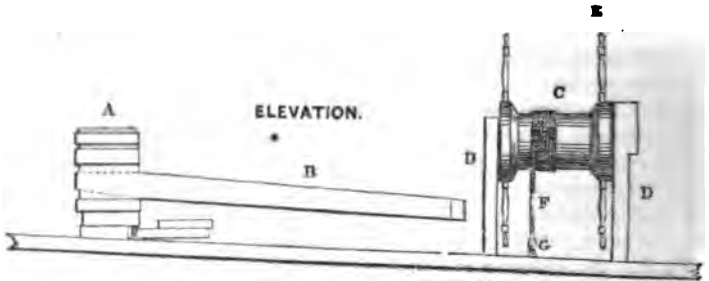

Tillar ropes wound round the barrel of the steering wheel (o). The wheel thence becomes the mechanical power denominated the wheel and axle, the spokes of it being the wheel of that power, and the barrel of it the axle.

The diameter of the barrel of the steering wheel is determined by the length of tillar rope which is required to be taken up in forcing the tillar over to the greatest angle, or in nautical terms putting the helm hard down, which angle for efficiency is considered in the Queen's service to be that of 42 degrees, from the fore and aft line of the vessel, out of the quadrant or 10 degrees. This is required on each side of the midship position of the tillar, and thence the quantity of tillar rope on the barrel of the steering wheel, when the helm or tillar is amidships, must be double that quantity, as half of it has to be unwound from it at either end, and added at the other according as the helm is put starboard or port, to the right hand or the left, so that the same number of turns of tillar rope are always on the barrel of the wheel; and when the helm is hard down either way, the whole number of turns are before or abaft the centre of the rope wound on the barrel in the midship position of the tillar. The number of turns of rope on the barrel of the steering wheels of the ships of the navy is five or seven; the odd number being requisite, that the centre of the tillar rope wound on the barrel of the wheel, when the helm is amidships, may be on the upper surface of the barrel, to which it is firmly secured, to prevent the tillar rope slipping round it.

g, Position of a block in the deck of the vessel, confining the tillar rope (f) on each side of the barrel of the steering wheel.

REFERENCES TO THE PLAN OF THE SKETCH.

A, Rudder head.

A B, Length of tillar.

C, Barrel of steering wheel.

D D, Sections of the stantions of the wheel of elevation.

g, Position of blocks in the deck, to confine the tillar rope (f) to the diameter of the barrel of the steering wheel.

f, Tillar ropes wound round the barrel of the wheel as shown on the elevation. The ends, after being so wound, are led first through the block (g); from thence through the block (i) at the side to a block (h) on either side of the end of the tillar (A B); from whence the end is led to the eye bolt (k), where it is drawn taut in and secured. The positions of the eye bolt (k) and block (i) to prevent slack rope, were determined on each side by the following process:—the tillar (A B of the plan) was put through an angle of 42 degrees each side of the fore and aft position shown on the sketch, and the portion of the circle thence

described by the end (B) of the tillar was marked on the deck; the tillar was then restored to the fore and aft position as in the sketch, and $\frac{1}{3}$ rd of the length of it, as denoted by the dotted line, was set off from the fore end of the tillar, and squared across the ship, giving the points marked *k* in the plan for the standing part or end of the tillar ropes, and $\frac{1}{12}$ th of *AB* was set before the end (B) of the tillar, and squared across the deck to meet the sides of the ship in the opposite points (i), to which blocks were fixed; and on the tillar rope being rove through these, in the manner before described, it was found that the tillar rope (P) was at equal stretch in every position of the tillar. When great accuracy is required, the points *k* and *I* should be relatively placed so that *I* in athwartship breadth may exceed *k* by $\frac{1}{4}$ th of *k*; or that the distance *II* is $\frac{1}{5}$ th times that of *kk*.

- L, Eye bolts placed on the tillar to receive the hooks of purchases or tackles called relieving tackles, by which the vessel is steered in the event of a casualty occurring to the tillar.

The tillar ropes of the navy are made of twisted hide.

PART XXIX.

References to the Sketches of the Head and Stern of a Frigate.—Outline of the Terms used to distinguish the several Portions of them.

THE sketch is descriptive of the component parts, or of the external fittings which form the head of a frigate. They are considered essential to the ship, either as forming a portion of the required arrangements for the efficiency of the movements of her, or to be necessary to complete the outward appearance of the ship. The finish given to the extremities of the ship, or to the head and stern (being an appeal to the taste and judgment of the observer through the medium of the eye), the naval architect should, in a great degree, regulate by that organ, as the best means of producing the desired effect—that of giving a light and graceful appearance to that part of the hull of the ship which is above the seat of water or line of immersion at which the vessel swims.

REFERENCES TO THE SKETCH OF THE HEAD.

Fig. 1.

- A, Berthing rail, forming the safety or guard to the men when they are out in the head, the flat or platform of which is on a level with the main rail (B).
 B, Main rail, to fashion out the head, and to afford an inclosed space for accommodation to the crew.
 C, Middle or small rail, introduced for the exterior appearance of the ship.

Sketch of the Head of a Frigate

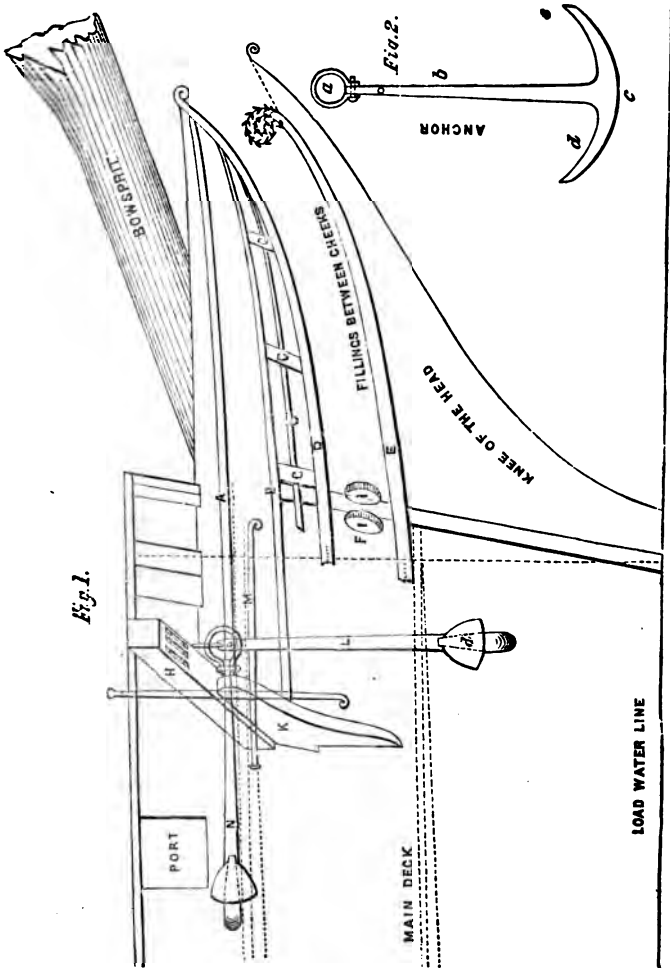

D, The after part of this fitting, with a portion of it 6 or 8 feet on the knee of the head, is called the upper cheek, and forms, by being bolted to the bows of the ship and to the knee of the head, a species of wooden knee to support

the latter. The after arm of this knee is shown in projection in the figure or picture of the bow of the ship; but on the knee of the head it describes the form and length of it. The moulding or breadth is usually at the throat of it, $2\frac{1}{2}$ times the depth of the cheek. The fore part of D is called an "eking," the extreme end of it, shown by a scroll on the figure, being termed a "hair bracket;" and this hair-bracket should, for symmetry of appearance, be placed rather below the shoulder of the figure-head.

B, Lower cheek, a wooden knee, as described for the upper cheek, and bolted also to the bows of the ship and knee of the head. The bolts in the knee of the head arms of these cheeks pass through similar knees on the reverse side of the knee of the head.

F, Bolsters of wood placed between the arms of the cheeks (D and B) that come against the bows of the ship. These bolsters are worked to form beds for the iron hawse pipes (I), which are put through the sides of the ship to form holes for the cables to run out of. The bolsters should slightly project over the moulding way or breadth of the cheeks, to form a protection to them. They are bolted to the side of the ship independently of the bolts which secure the hawse pipes (I). Immediately forward of the bolsters, a piece of wood termed a corner chock is usually worked, the intention of it being that the fore ends of the planks, called wood ends, may, by the removal of it, be caulked without disturbing or taking out the hawse pipes, or taking down the bolsters, an operation attended with expense and loss of time.

The fillings between the cheeks on the knee of the head are of fir, and are intended solely for the better appearance of the ship, under which view of their utility they have been in many instances dispensed with.

G, Timbers of the head, to support the middle and main rails. For a light and airy appearance, the after one is placed to the rake or inclination of the stem; the next with $1\frac{1}{2}$ inches more rake; and the foremost one with $1\frac{1}{2}$ inches more rake than that, or with 3 inches more rake to it than the one at the stem.

There is a thin birthing of board placed between A and B; and over A what is termed a wash board is sometimes used, while this is much oftener supplied by an iron rod, termed an iron horse, to which painted canvas is affixed.

H, Cathead, to raise the anchor from the water's edge.

K, Supporter or knee to H, bolted firmly to the side of the ship and to the cathead. The use of it is expressed by the name given to it, that of a support to the cathead.

L, Anchor hanging to the cathead, or what the sailors termed cock-billed.

M, Anchor stowed on the bill board.

Angular pieces of fir, called wash boards, are placed under the lower cheeks and ekinga.

Fig. 2 (Anchor in parts).

Shackle to which the cable is united.

Shank of the anchor.

Crown of the anchor.

Palm of the anchor.

Pea of the anchor.

SKETCH OF THE STERN OF A FRIGATE.

The taste of the practical man will be tested in the fittings of the stern of the ship, in the same ratio as for those employed for the embellishment of the head of her, with this additional difficulty to overcome in the former—that of having to please the eye under the changes in point of view, which take place while the sight is carrying round curves from the sloping or raking surface presented by the right aft stern, to the perpendicular plane forming the fore and aft plane or topsides of the ship.

REFERENCES TO THE FIGURE, p. 168.

- A, Taffrail.
 B, Boundary rail, or moulding to form part of the decoration to the stern.
 C, Cove rail.
 D, Heading to lights or windows, marked F.
 F, Windows framed as in the houses on shore, having cills to them termed water tables. They are hung in sashes, upper and lower, with weights, and the shutters fitted to them are called dead-lights, a name that has conjured up the fears of many a landsman.
 H, Upper counter rail. } These are brought on against the timbers of the
 G, Lower counter rail. } frame, and form plank and projecting moulding.
 E, Quarter pieces, allowing accommodation to the captain outside the ship.
 K, Lower finishing, wholly for appearance.
 L, The plank of the bottom, or buttock plank, housed under the lower counter rail (G). This plank should be worked without the use of an edge set to prevent its being crippled.
 M, Life buoy, fitted over the stern.
 N, Munion, to fashion out the window and inclose the grooves for the sash-weights.

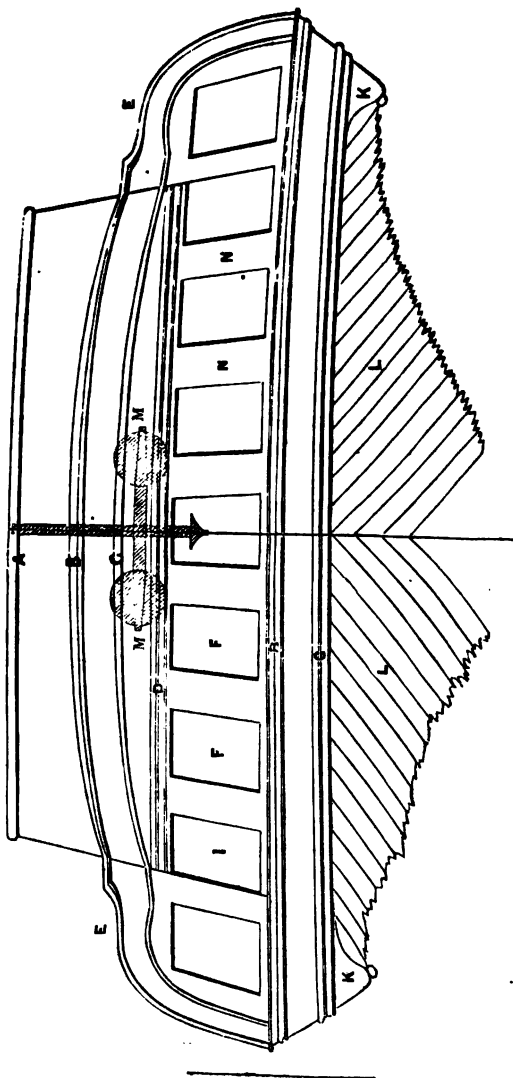

Sketch of the Stern of a Frigate.

PART XXX.

A short Description of the Process used to make the Seams of the Planks of a Vessel impervious to Water.—Terms of some of the Tools used for that purpose.—Scale of the Width of Seams according to Thickness.—Seams of Decks sometimes payed with Jeffery's Marine Glue.—Copper Sheathing employed on the immersed Portions of the Ships of the Navy formerly payed with Pitch and Tar.—Weight of Copper Sheathing to each superficial Foot.—Concluding Remarks.

THE joints of the external planking, or what are mechanically termed the seams of the planks, require to be made impervious to the water, that the ship may swim, which is effected by forcing into them, by means of sharp iron wedges called caulking irons, spun threads or layers of oakum, formed by taking to pieces, in the Queen's service, the unserviceable ropes and cables, after such have been cut up into short lengths, termed "junk." The seams of the planking, when they are under the standard width for the several thicknesses of it, are opened to that required, by sharp and large iron wedges called reeming irons being driven into them by a heavy mallet, which in the trade is styled a beetle; and in this operation the skill of the caulker is drawn out, and the work of the shipwright-ried. The opening of the seams by such a powerful set, or mechanical force, as that formed by a range of wedges of such acute or small angles being acted upon by the impetus given to them, from the smart and forcible blow of the heavy mallet or beetle, must close the seams above and below the one that is wished to be increased, and thence bring a strain on the fastenings of both planks: the caulker should therefore be careful to first caulk those seams which are under the standard width, and which are situated above or below seams that may be over the same width; and the shipwright should be in attendance, that, should the planking be forced off from the bottom by the operation of reeming—which it will be, especially where the seams or joints do not stand square to the timbers—he may put in additional fastenings before the caulking is finally proceeded

with. The stipulated number of threads of oakum having been forced into the seams by the mallet and iron of the caulker, the whole is the more firmly bedded and united, and buried within the edges of the planks by the work being what the trade call "horsed up," an operation that requires two caulkers, the one holding by means of a handle the meeking or making iron to the seam which has been caulked, while the other drives on it with the full swing or blow of the beetle. After this process, melted pitch is payed by the means of small mops over the thus forced-up oakum; and finally, as high up the bottom of the ship as the copper sheathing will come, a thread of spun yarn is laid in to make the seam flush or level with the planking, that the copper sheathing hereafter to be described may be laid smoother on it. The bottom of the vessel is also payed up or covered over by the caulker as high as where the copper sheathing is placed, with a mixture of pitch and tar. The decks of a ship are caulked in a similar manner with oakum; but the weather decks are payed with Jeffery's marine glue instead of pitch.

Scale of the Width of Seam according to the Thickness of Wales, Bottom Plank, and Decks, with the Standard Number of Threads of Oakum to be placed in each.

A scale for the width of the seam, according to the thickness of the plank, is formed practically by opening a 2-foot rule to the angle produced by $\frac{1}{8}$ ths of an inch at the extreme inner edges of the 12-inch arms of it.

Number of Threads of Oakum to be worked into the Seams of the Wales, Diminishing Plank and Bottom.

Thickness.	No. of threads.
2 inches	2
3 "	4
4 "	5
5 "	6
6 "	7
7 "	9
8 "	10
9 "	11
10 "	18

Thickness.	<i>Decks.</i>					No. of threads.
2 inches	2 small.
3 "	2 "
4 "	3 "
5 "	4 "

The caulking always tends to stiffen the fabric of a ship, and it has thence been sometimes the practice not to caulk the internal planking until the ship has had several years' service at sea, when the caulking of it has been supposed to be the means of adding strength to the racked or strained fastenings of her.

COPPER SHEATHING ON THE BOTTOM OF SHIPS.

Up to the latter end of the last century it was the practice, in the navy of this country, that the immersed portions of the ships should be, as most of the ships of the mercantile navy are to this day, alone covered with a thick coating of pitch and tar. The quick growth of marine vegetable matter on the bottoms of Her Majesty's ships, which impeded their way through the water, when thus protected but partially from the destructive ravages of the sea-worm, added to the expense and delay which arose from the necessity of frequently having to dock the ships to bream them, or place lighted reeds under the bottoms of them, when in dock, to remove such vegetation; and that when on foreign stations, where this practice could not be followed up, and the sailing of the vessels was, from the foulness of the external planking under water, in some measure lost, led to the introduction of a thin coating of copper, called copper sheathing, being placed over the whole intended immersed portion of the bottom; and to the extent of 18 inches above that line of immersion. This coating is formed of sheets of copper in lengths of 4 feet and 14 inches breadth, the lower edges of the upper sheets lapping over the upper edges of those below them, and the after end of each sheet lapping over the fore end of the one immediately following it: the

thicknesses of the several descriptions of copper sheathing used in Her Majesty's navy are such as to make each superficial foot in extent of the several respective weights of 32 oz., 28 oz., 18 oz., and 16 oz., and under these denominations they are known in the trade. The 32 oz. copper sheathing, which is the thickest, is used all round the ship at the height of the load-water line for four strakes or sheets down, and on the fore part of her, on the bows down to the keel. The practice is to have, of the whole number of sheets of copper sheathing required to cover the surface of the bottom of the ship, $\frac{1}{3}$ rd of 32 oz. and the remaining $\frac{2}{3}$ rds of 28 oz., expending the residue of the 32 oz. copper sheathing, after working four strakes all round her, on the bows of the ship. The 18 and 16 oz. sheathing copper is usually placed between the main and false keels, to protect the former from the worm should the latter be forced off.

A species of metal, or a combination of metals, denominated Muntz's metal, has been of late generally used in the mercantile navy, and has been partially employed in the British navy, as being inexpensive when compared with copper sheathing.

No. of Sheets, &c., from a 120-Gun Ship to a 10-Gun Brig.

Guns.	Sheets, of 4 ft. by 14 ins.
120	4444
84	3400
60	2250
46	1870
28	1240
10	638

The combination of the several parts, and the arrangement of the respective portions, of the vast structure which constitutes the man-of-war or ship for national defence having been detailed, it becomes necessary, under the prescribed limits of a rudimentary treatise, to bring to a close the brief remarks that have been made on that important subject—the practical carpentry of ships, as forming either the National Bulwarks of this country, or those on which, considered

in a nation of merchants, the Commerce, and thence the riches, of England depend—the mercantile navy of England. In the practice of ship building a wide field is opened for discussion, as the several systems that have from time to time been adopted admit freely of controversy.

In many instances the same end is to be obtained by either of two methods, and thence advocating their relative or respective merits could be productive of no positive good. Under such impressions, the plans proposed for the same purpose have, in this small work, been only described, leaving those who read such descriptions to draw their own conclusions as to their advantages or disadvantages in practice. With the hope that the practical hints which may here be found, and which have been compiled during the leisure hours of a professional course of duties, may be considered useful to the novice in ship building, as forming the lower step of a ladder towards his attaining a knowledge of practical ship building, when followed by him as a trade, and also be acceptable to the general reader, as a source of amusement and recreation from more abstruse reading, this Rudimentary Treatise on Practical Ship Building is brought to a conclusion; but still with a hope that it will be shortly followed by a Rudimentary Treatise on Masting, Mast-Making, and Rigging of Ships.

Plate 1.

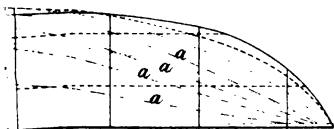
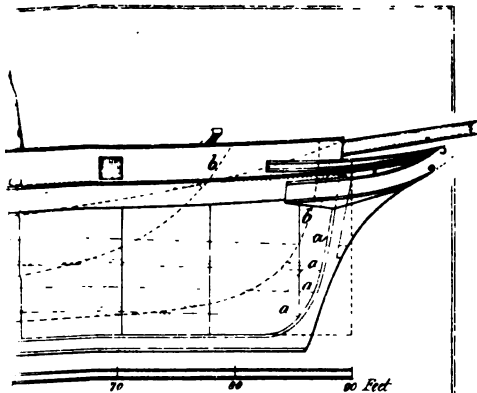

Dimensions

	Ft	in
between Perpendiculars.	90.	0
of Keel for Tonnage.	76.	10 ³ / ₄
extreme.	22.	2
Tonnage.	21.	11
loaded.	21.	6
of Hold.	11.	0

Burthen in Tons 196 ⁴⁵/₃₄

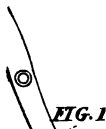
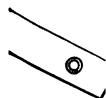
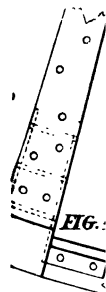

SIR R. SEPPINGS' PLAN.

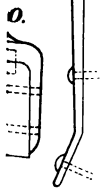

Eng 5058.49
Rudiments of naval architecture;
Cabot Science 006277517



3 2044 091 859 017